

SETTEE ASSEMBLY INSTRUCTIONS

DS-2185-400

Questions? Call 1-800-994-3390

MADE IN CHINA

Parts and Hardware

Please check to make sure you have all parts and hardware before starting the assembly process.
(Attention: The Legs & Hardware bag can be found in the bottom of Seat.)

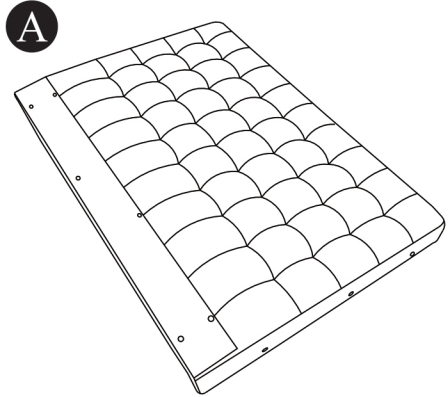

x 1
Back Cushion

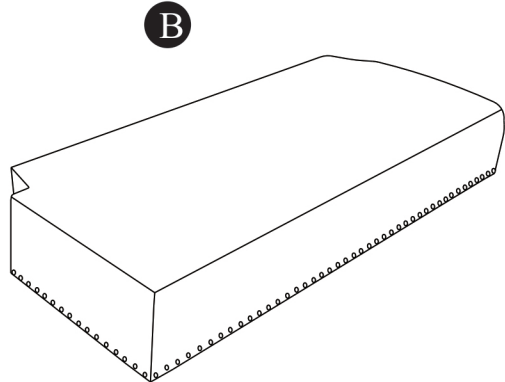

x 1
Seat Cushion

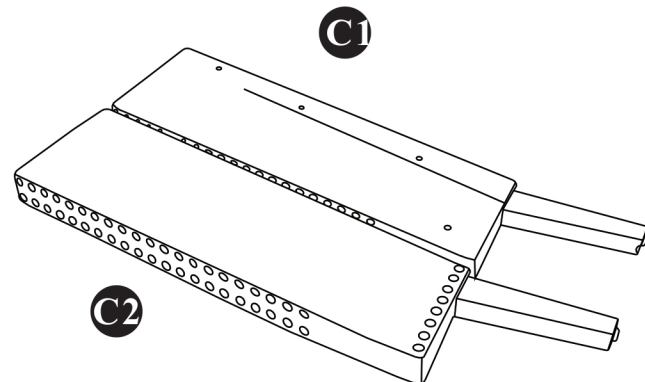

x 2
Back Cushion Wings



x 2
Legs

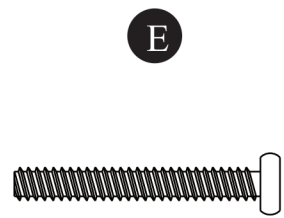

x 14
Allen Head Bolts
0.3125in x65mm

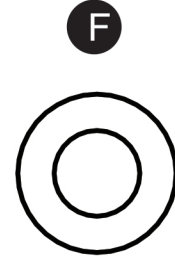

x14
Flat Washers



x 14
Spring Washers



x 2
Plastic Washers

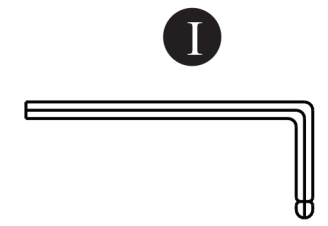

x 1
Allen Wrench

SETTEE ASSEMBLY INSTRUCTIONS

DS-2185-400

Questions? Call 1-800-994-3390

MADE IN CHINA

Assembly Instructions

Please read and understand all assembly instructions before beginning assembly process.

STEP1: Attach Legs(D) and Plastic Washers(H) to bottom of Seat Cushion(B), turn right to tighten. *(Instructions shows Settee viewed from the bottom.)*

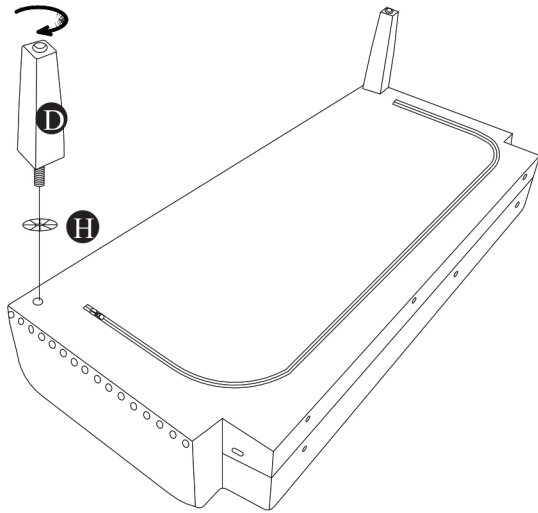

STEP2: Attach Back Cushion(A) to Seat Cushion(B), using Allen Head Bolts(E), Flat Washers(F) and Spring Washers(G), tighten with Allen Wrench(I).

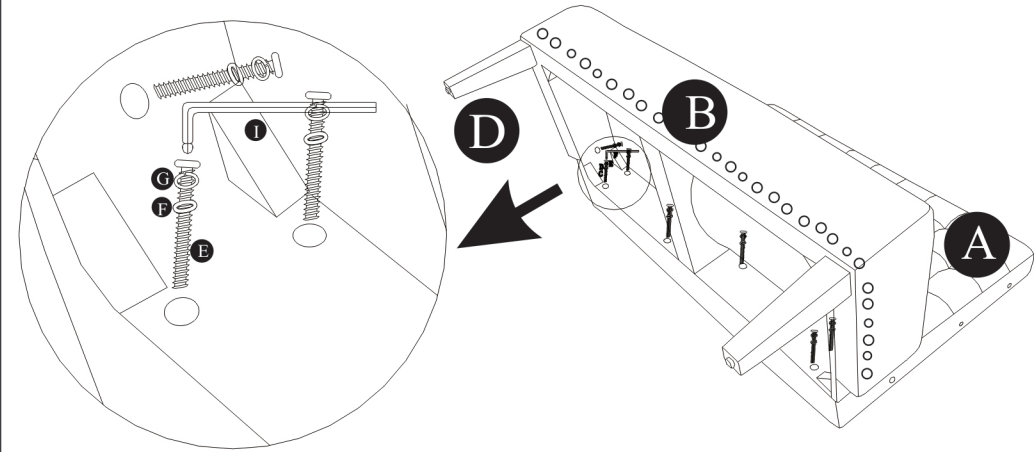

STEP3: Attach Back Cushion Wings(C1 & C2) to Back Cushion(A), using Allen Head Bolts(E), Flat Washers(F) and Spring washers(G), tighten with Allen Wrench(I).

