

ASSEMBLY INSTRUCTION



VENDOR CODE: TXNS
STOCK#:8170-10 LOVESEAT

SKU#:10281715
SKU#:10281727

MANUFACTURED FOR ROOMS TO GO

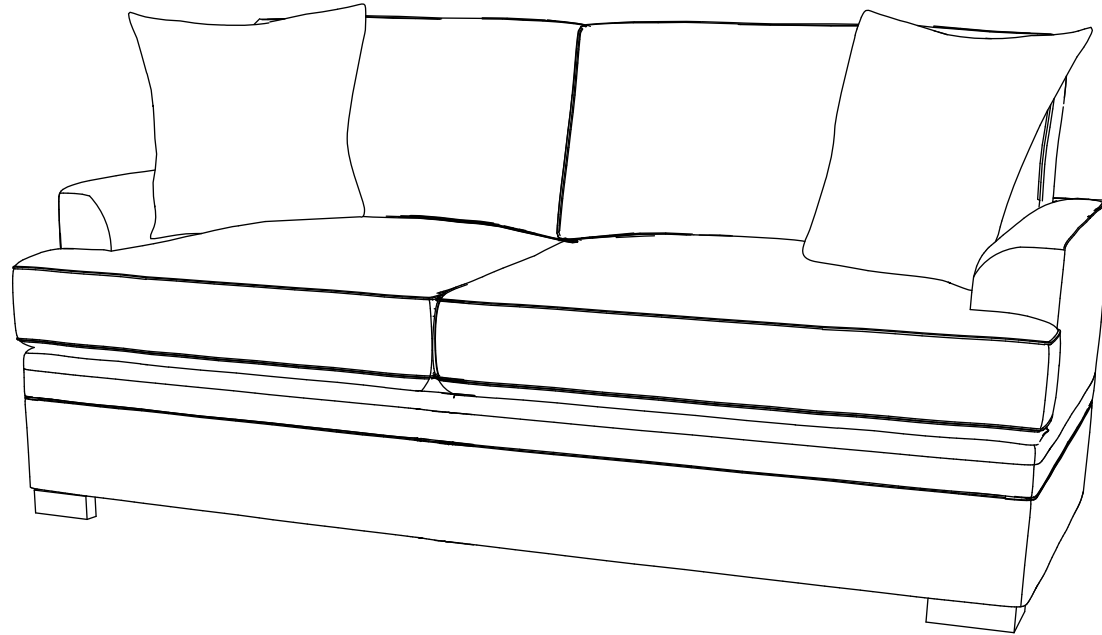









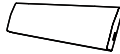

MANUFACTURED FOR ROOMS TO GO

Part Location

VENDOR CODE: TXNS
 STOCK#:8170-10 LOVESEAT

SKU#:10281715
 SKU#:10281727

TOOLS REQUIRED: No			
PART LIST			
NO	Description	Sketch	Quantity
A	BACK		1
B	SEAT FRAME		1
C	BACK CUSHIONS		2
D	SEAT CUSHIONS		2
E	CORNER FEET		4
F	PILLOWS		2
G	BOLTS 1/4"-20 x 45MM		8
H	Allen Key 5/32"		1

Seat and back cushions (part C & D) are packed stacked with the back on top (part A).

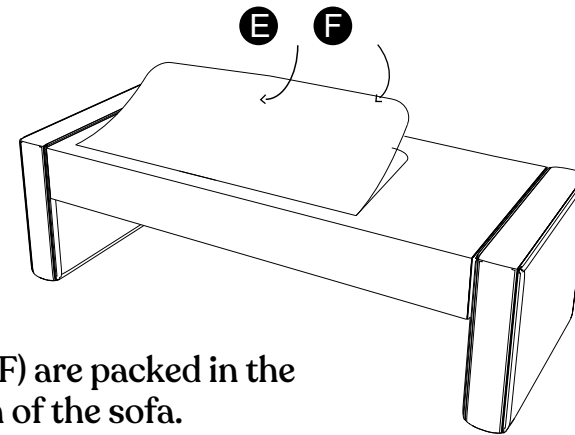
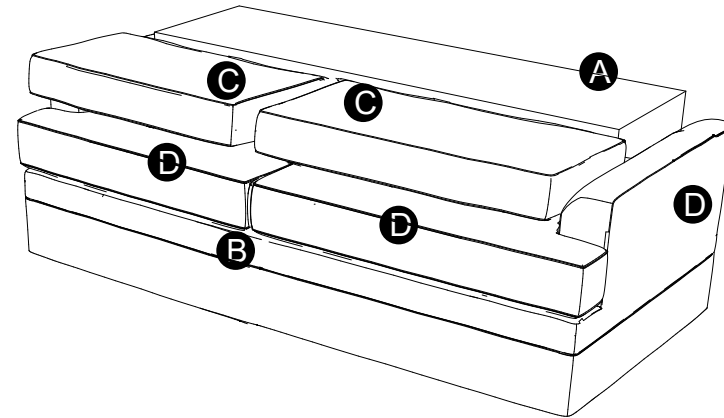

Legs (part E) and pillows (part F) are packed in the zippered pocket on the bottom of the sofa.



ASSEMBLY

VENDOR CODE: TXNS
STOCK#:8170-10 LOVESEAT

SKU#:10281715
SKU#:10281727

MANUFACTURED FOR ROOMS TO GO

Step 1

Slide down backrest (part A) in brackets of arms (parts B).

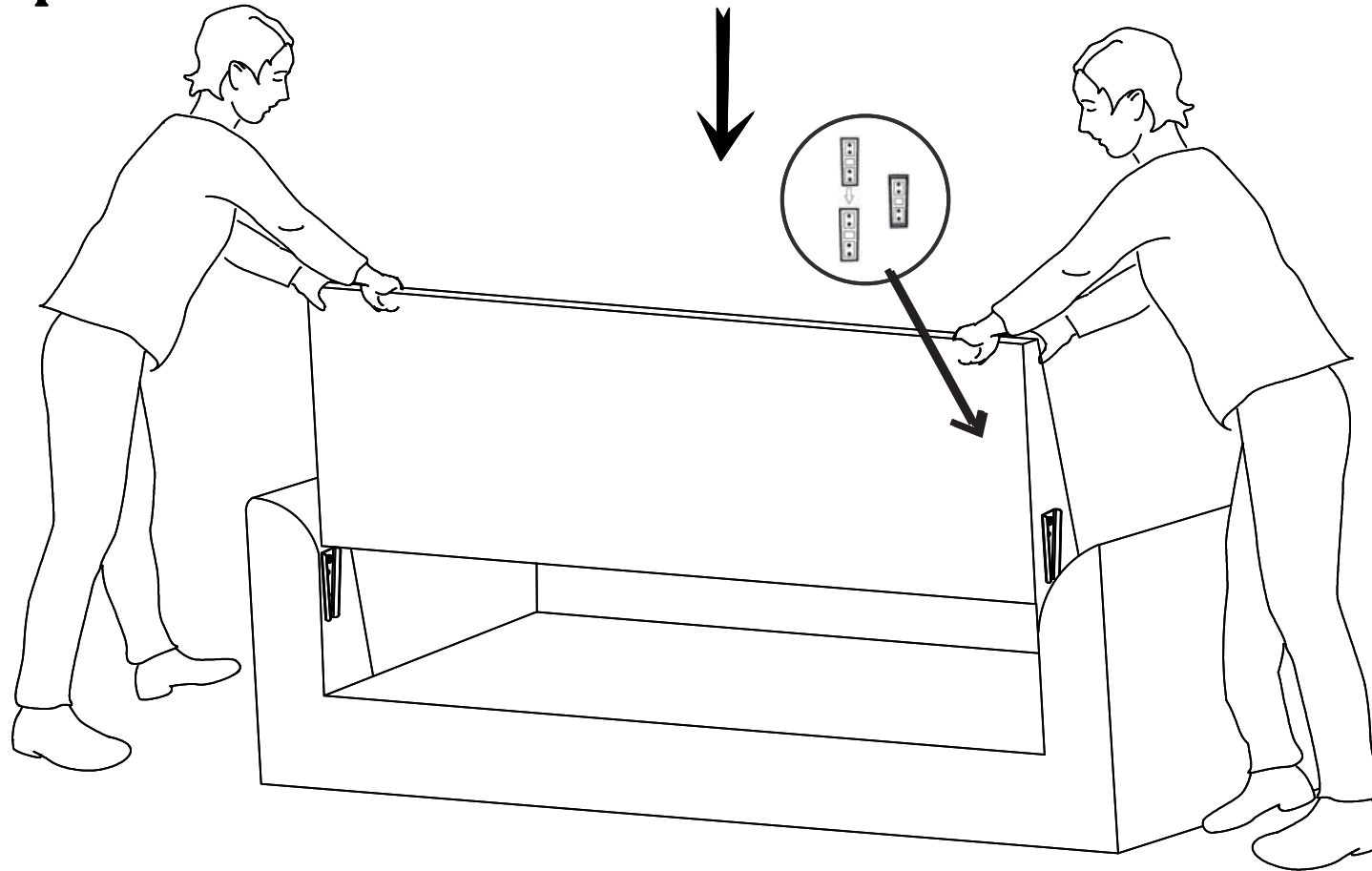



ASSEMBLY

VENDOR CODE: TXNS
STOCK#:8170-10 LOVESEAT

SKU#:10281715
SKU#:10281727

MANUFACTURED FOR ROOMS TO GO

Step 2

Use provided allen wrench to tighten bolts (part G) through feet (part E) to base (part B). Tighten center leg (part F) to base by rotating in.

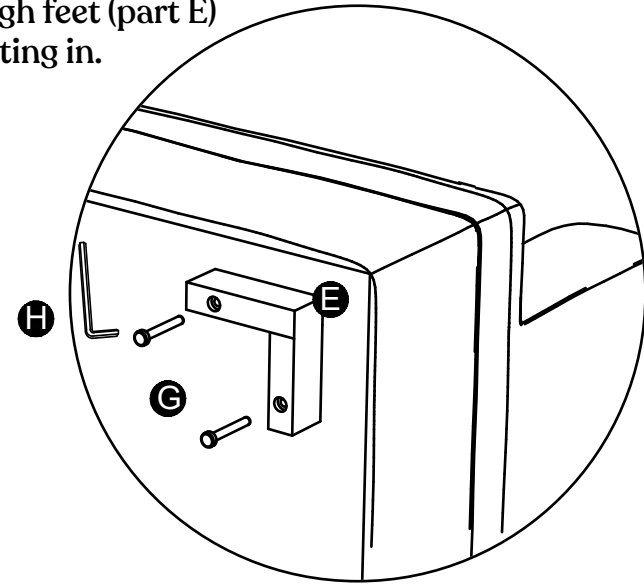
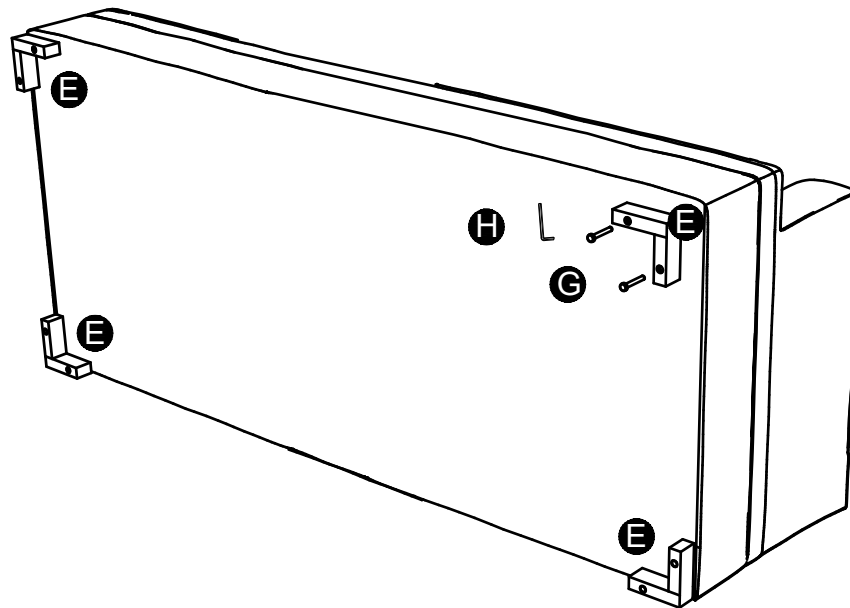



ASSEMBLY

VENDOR CODE: TXNS
STOCK#:8170-10 LOVESEAT

SKU#:10281715
SKU#:10281727

MANUFACTURED FOR ROOMS TO GO

Step 3

Add seat cushions (parts D) and back cushions (parts C). Cushions with L shape go on outside.
Add throw pillows (parts H) to top of seat cushions (parts D).

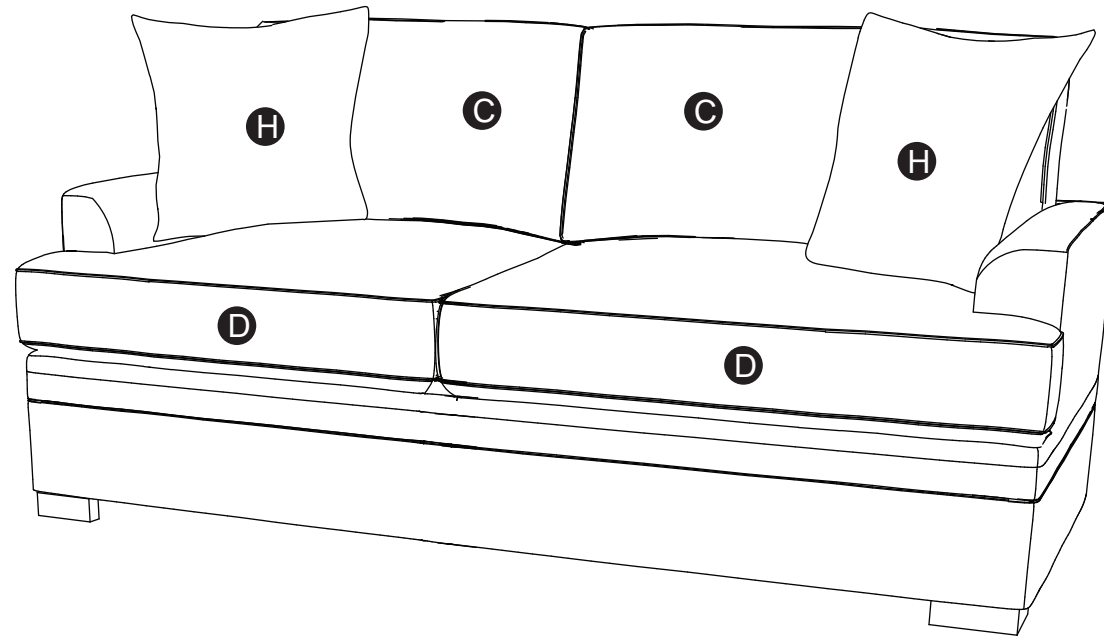

ASSEMBLY



VENDOR CODE: TXNS
STOCK#:8170-10 LOVESEAT

SKU#:10281715
SKU#:10281727

MANUFACTURED FOR ROOMS TO GO

Step 4

Secure back flap on back (part A) to seat back (part B) by pushing down and connecting velcro to finish assembly.

