

STEP 1:

TOOLS REQUIRED:NO TOOLS REQUIRED

PART LIST

NO.	Description		Q'TY
A	CHAIR		1PC
B	BACK CUSHION		1PC
C	LEGS		4PCS

HARDWARE LIST

1	BOLT (1/4x18x32 ^m / _m)		12PCS
	SPRING WASHER (1/4x13x1.5 ^m / _m)		
	FLAT WASHER (1/4x19x2 ^m / _m)		
2	ALLEN KEY (4 ^m / _m x32 x75)		1PC

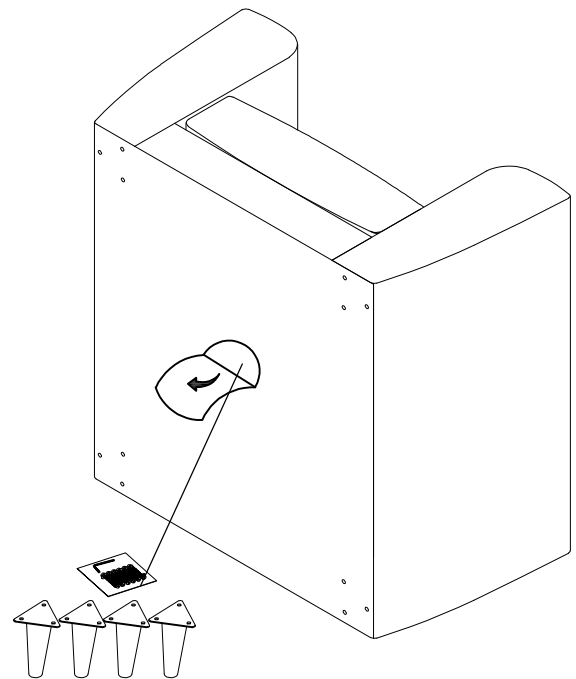

Hardware Pack + Legs inside

STEP 2:

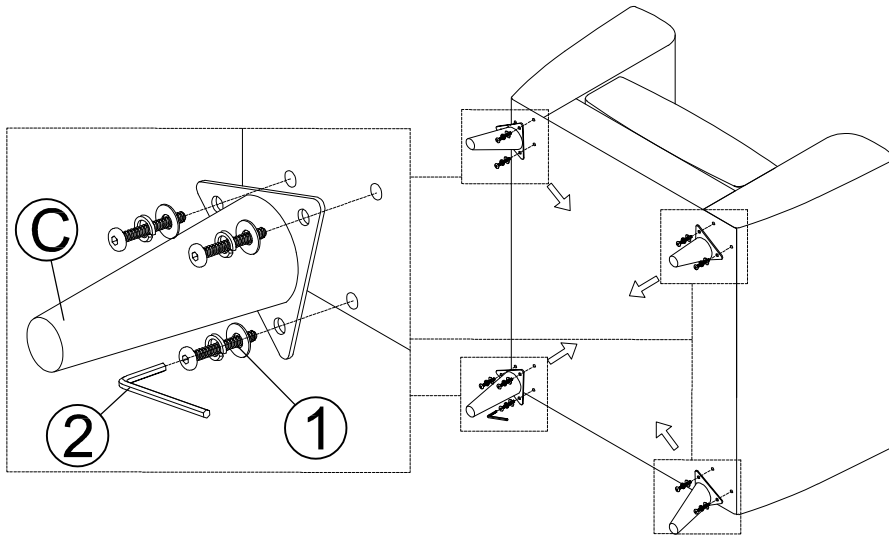

STEP 3:

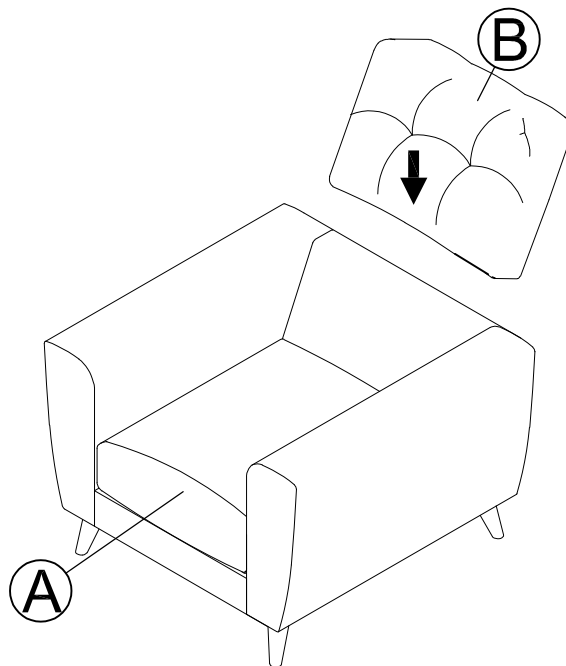

Completed

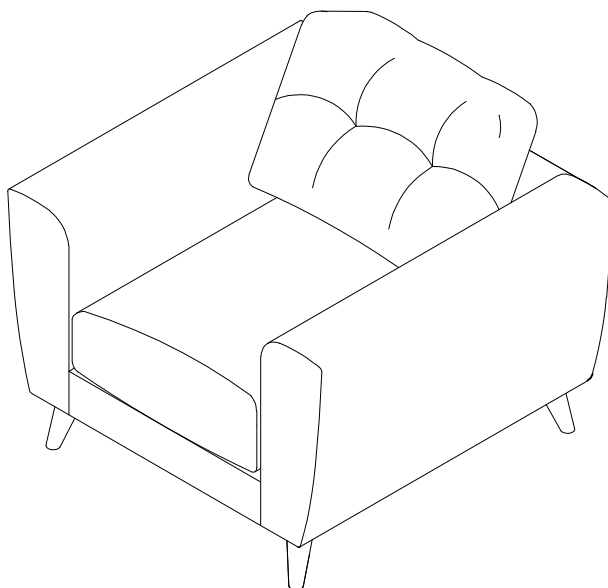

Caring for Your Furniture

To ensure your chair maintains its beauty, comfort, and durability for years to come, please follow these Care & Maintenance Guidelines.

The Enemies of Furniture

To extend the life of your chair, avoid exposure to these common threats:

- **Sunlight & Heat:** Direct sunlight or heat sources may cause fading or weakening of the fabric. Place the chair away from strong sunlight, radiators, or heating vents.
- **Moisture:** Wipe up spills immediately and avoid placing the chair in damp or humid areas. Excess moisture may damage both the fabric and the wooden legs.
- **Harsh Chemicals:** Do not use bleach, ammonia, or solvent-based cleaners on the fabric or on the black dust-cover underneath. Use only mild soap and clean water when needed.
- **Sharp Objects:** Keep keys, tools, pet claws, or other sharp items away from the fabric surface to prevent snags or tears.
- **Uneven Surfaces:** Place the chair on even flooring to avoid unnecessary stress on the wooden legs, support leg and the overall frame.

Tips for Better Maintenance

Simple care routines will keep your chair looking and feeling its best:

- **Weekly Dusting:** Vacuum the fabric using a soft brush attachment to remove dust and debris.
- **Spot Cleaning:** Blot (do not rub) minor stains with a mild soap solution and a clean damp cloth. Allow to air dry fully.
- **Cushion Care:** Fluff and rotate the cushion regularly to maintain its shape and comfort.
- **Wood Care:** Wipe the wooden legs using a soft, dry cloth. Avoid soaking or wet-mopping around the legs to prevent moisture absorption.
- **Hardware Check:** Periodically inspect and gently tighten the bolts underneath the chair to maintain stability.

With proper care, your chair will remain stylish, comfortable, and supportive for years to come.

☞ For indoor residential use only.