



Manufactured for Rooms To Go

ASSEMBLY INSTRUCTION

VENDOR CODE: CAVS
STOCK#: 8019B-1 CHAIR

SKU#: 14280236
SKU#: 14280248

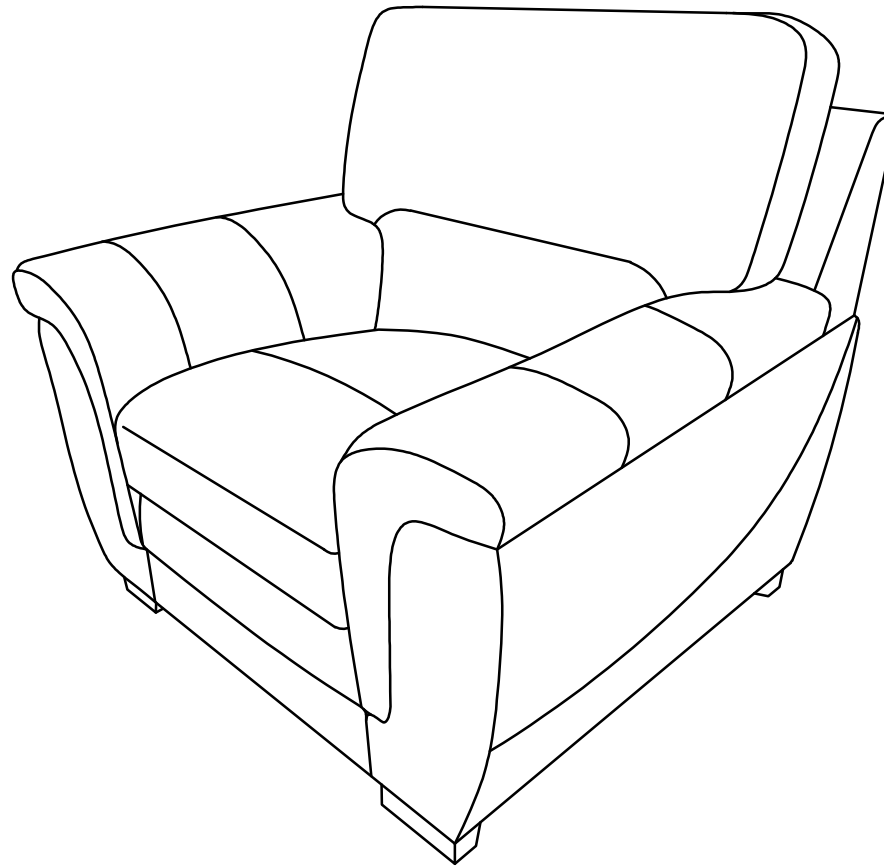

①



LIST OF PART







VENDOR CODE: CAVS
STOCK#: 8019B-1 CHAIR

SKU#: 14280236
SKU#: 14280248

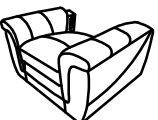
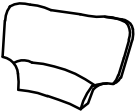
Manufactured for Rooms To Go

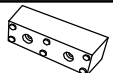
TOOLS REQUIRED: YES (SCREWDRIVER)

PART LIST

NO	Description	Sketch	Quantity
A	BACK		1
B	SEAT FRAME		1
C	BACK CUSHION		1
D	LEFT EAR		1
E	RIGHT EAR		1
F	LEG		4
G	ALLEN BOLT φM8*60mm		8
H	FLAT WASHER φ5/16"*19*2mm		8
I	ALLEN KEY M5*100*38mm		1

Location of KD parts

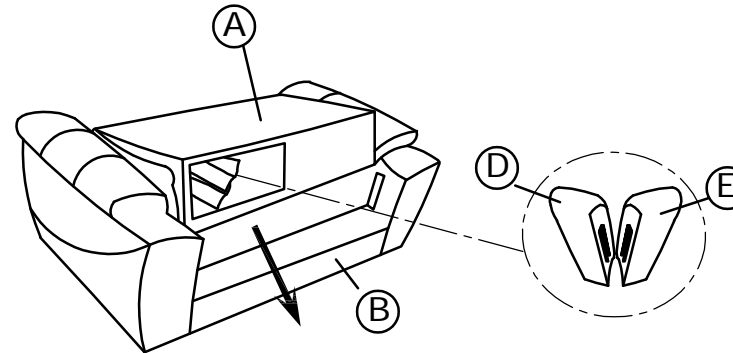

Take out left / right ear / legs from the back.

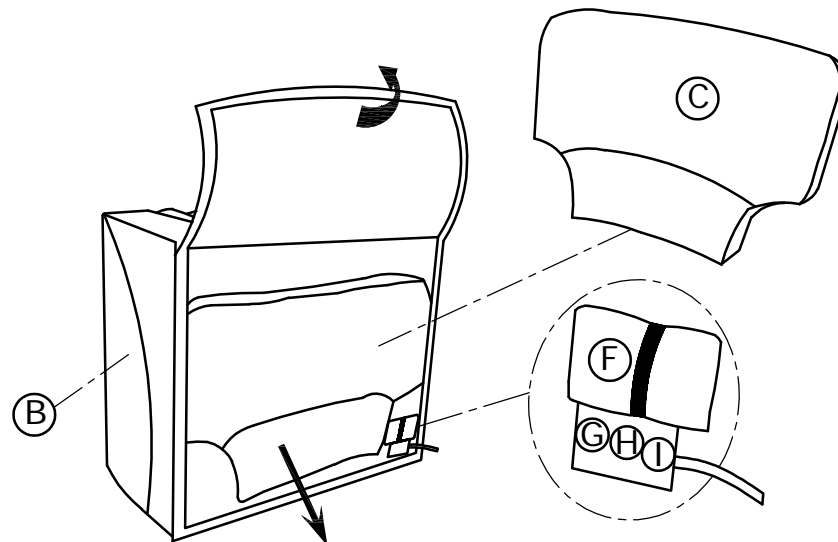

Take out back cushion from the seat frame bottom.



ASSEMBLY INSTRUCTION

VENDOR CODE: CAVS
STOCK#: 8019B-1 CHAIR

SKU#: 14280236
SKU#: 14280248

Manufactured for Rooms To Go

STEP 1: Insert back (A) into seat frame (B).

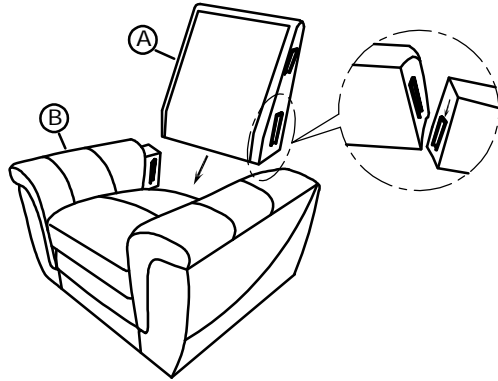

STEP 2: Screw legs (F) with Allen Bolt (G) and Flat Washer (H) in the Seat Frame (B) by Allen Key (I).

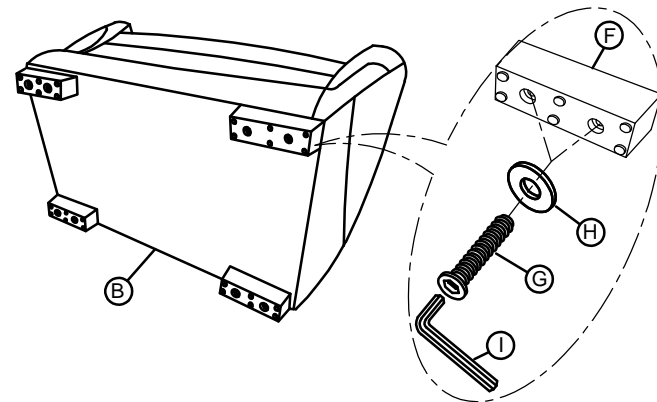

STEP 3: Attach back cushion (C) on the back (A) by velcro.

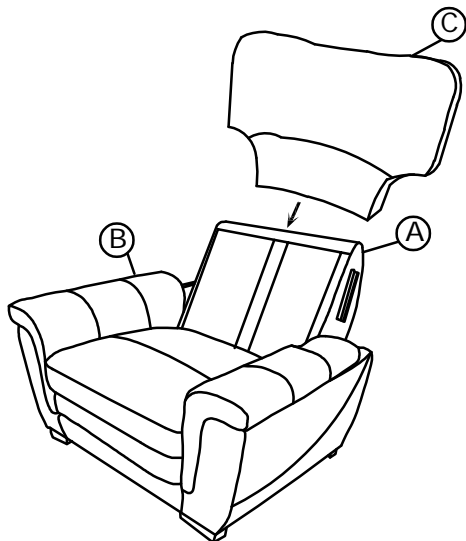

STEP 4: Attach left ear (D) and right ear (E) to back (A).
The chair is completed.

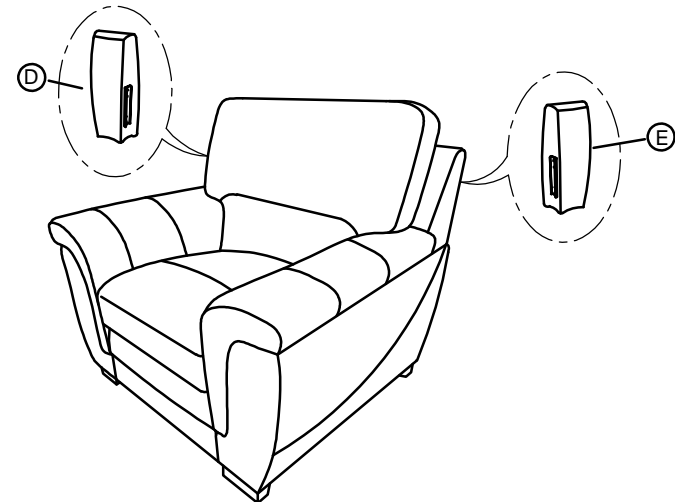



ASSEMBLY INSTRUCTION

VENDOR CODE: CAVS
STOCK#: 8019B-1 CHAIR

SKU#: 14280236
SKU#: 14280248

Manufactured for Rooms To Go

- *Avoid placing unit in areas where unit can be exposed to direct sunlight other powerful light sources
 - *Keep unit at least 24" from all heat sources.
- As fading or discoloration may occur.

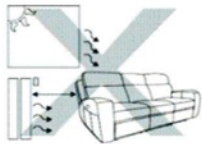

- *Do not reach under seat when mechanism is operating or serious injury may occur.
- *Reclining mechanism should only be operated while seated properly.



Do not sit on arms or backrest
Do not jump or roughhouse on furniture



*If unit must be moved, do not drag. Unit must be lifted in order to be moved.



Do not continuously operate mechanism for more than one minute or unit may go into protection mode by shutting down to prevent overheating.

- *Unplug unit from power source prior to cleaning mechanism.
- *Do not allow electrical components to come into contact with any liquids.

CARE AND CLEANING

*Upholstered furniture is packaged tightly to protect it during transit. This packaging can sometimes cause creases or misshaped cushions when the furniture comes out of the packaging. These issues will correct themselves over time as the fibers of the cushions are exposed to air. However, shaping the cushions with your hands can alleviate the creases and compressed fibers more quickly.



Before shaping After shaping

- *Dust often and use a vacuum cleaner to remove debris from seams and crevasses.
- *Use a soft damp cloth to gently clean soiled areas and wipe clean. Do not rub.
- *Do not use household cleaners or solvents. Such cleaners may cause damage and/or discoloration.
- *Do regularly use dedicated leather care product onto the leather furniture to prevent built up of body oils.