



ASSEMBLY INSTRUCTION

(Version 2, updated Dec. 2025)

RECLINING LOVESEAT

HLVN 7990

Manufactured for Rooms To Go

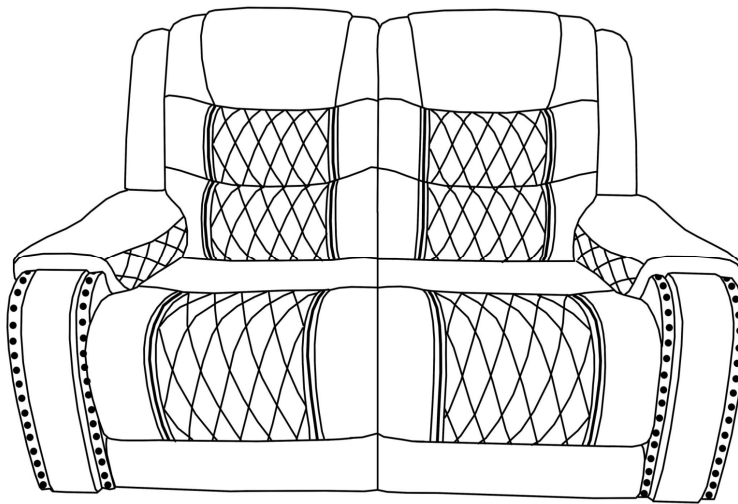

HLVN

SKU:

79901-52

15379907



79902-52

15379919

79904-52

15379933

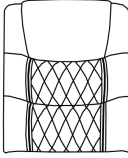
LIST OF PARTS

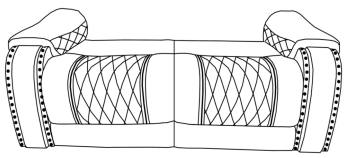
NO.	Description	Item	Quantity
A	Backrest (LSF, RSF)		2
B	LSF Wing		1
C	RSF Wing		1
D	Seat		1

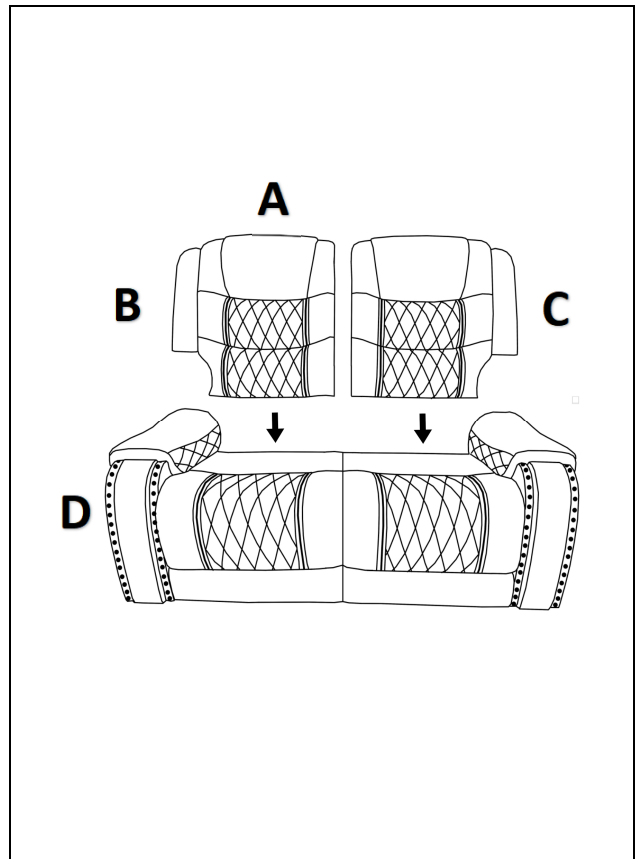

ASSEMBLY INSTRUCTIONS

Step 1: Take out carefully the back cushions, wings & seat from the packing.

Step 2: Positioning the female metal receiver brackets over the male metal posts. Push down the female brackets over male posts simultaneously until each side is locked into place an audible "click" is heard.

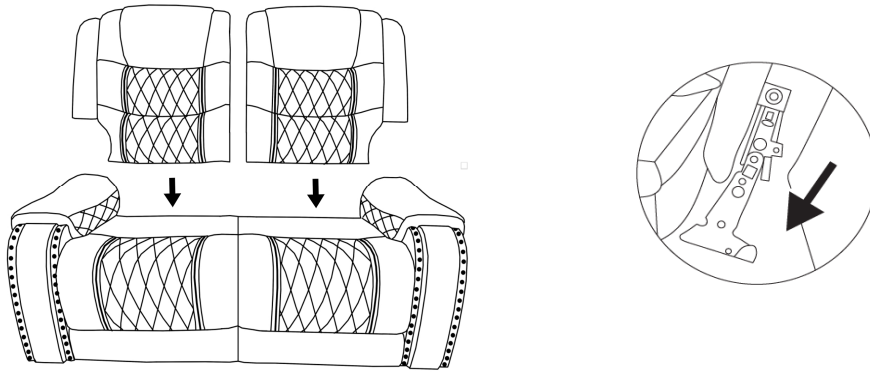

WARNINGS

- * Keep unit at least 4" from wall.
- * Keep unit at least 24" from all heat sources.
- * Avoid placing unit in areas where unit can be exposed to direct sunlight other powerful light sources, as fading or discoloration may occur.

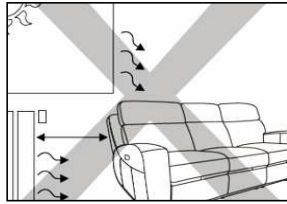

- * Do not reach under seat when mechanism is operating or serious injury may occur.
- * Reclining mechanism should only be operated while seated properly.



- * Do not sit on arms or backrest.
- * Do not jump or roughhouse on furniture

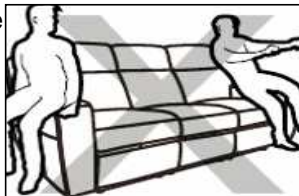

- * If unit must be moved, do not drag. Unit must be lifted in order to be moved.

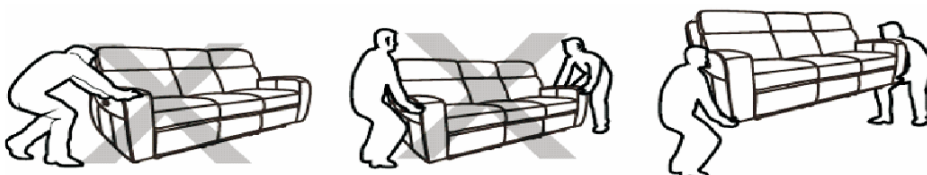

CARE AND CLEANING

* Upholstered furniture is packaged tightly to protect it during transit. This packaging can sometimes cause creases or misshaped cushions when the furniture comes out of the packaging. These issues will correct themselves over time as the fibers of the cushions are exposed to air. However, shaping the cushions with your hands can alleviate the creases and compressed fibers more quickly.



Before shaping



After shaping



- * Use a vacuum cleaner to remove dust and debris from seams and crevasses.
- * Use a soft damp cloth to gently clean soiled areas and wipe clean. Do not rub.
- * Do not use household cleaners or solvents. Such cleaners may cause damage and/or discoloration.
- * Do regularly use dedicated leather care product onto the leather furniture to prevent built up of body oils.

TROUBLE SHOOTING

PROBLEM	SOLUTION
Backrests gaps	Ensure the backrests are properly clipped into the male posts located on seat mechanism. Check that brackets are not loose, positioned improperly or bent.