







Assembly Instructions



SWSU 1123 RECLINER LOVESEAT

SKU#15411250
SKU#15411262
SKU#15411236

Manufactured for Rooms To Go

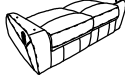
No	Description	Hardware	Q'TY
A	Stud M8 X 90MM		4 Pcs
B	M8 x 32mm Diameter Thread Clamping Star knob		4 Pcs
C	Left Arm Pillow		1 Pc
D	Right Arm Pillow		1 Pc
E	Left Backrest		1 Pc
F	Right Backrest		1 Pc
G	Seat		1 Pc

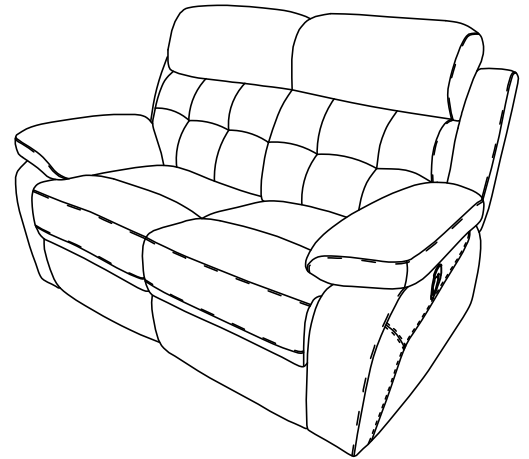



Assembly Instructions

SWSU 1123 RECLINER LOVESEAT

SKU#15411250
SKU#15411262
SKU#15411236

Manufactured for Rooms To Go

*****Caution:** Please read all instructions carefully before starting the assembly process. These parts are cumbersome and heavy. Therefore, two people are recommended in order to prevent personal injury and insure the parts are not damaged during the assembly.

Step 1:

*Take out the part C & D from bottom.

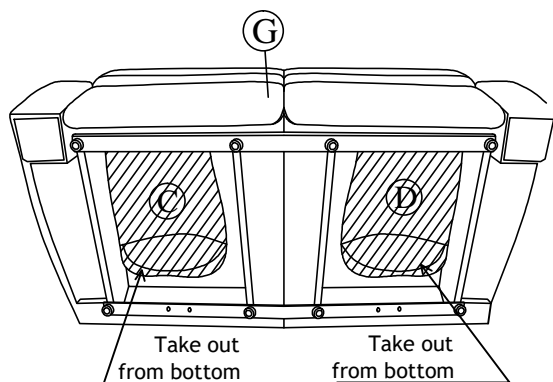

Step 2:

*Remove part B from part A.

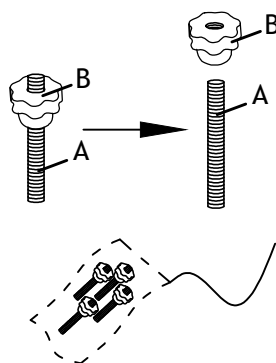

Step 3:

*Install part A into the arm pillow.

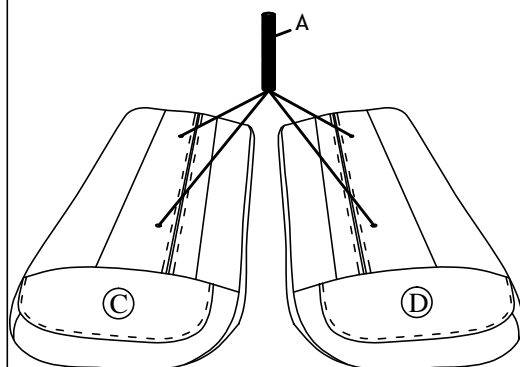

Step 4:

- i Place the arm pillow Right into the arm rest.
- ii Tight up part A with part B.

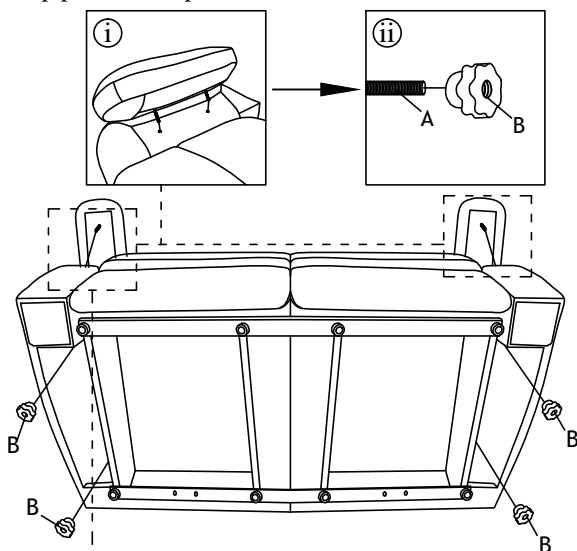

Step 5:

*Install the backrest E,F by positioning the female metal receiver bracket over the male metal posts.

