

ASSEMBLY INSTRUCTIONS

Description: Lounge







Important safety instructions:

- Please carefully read all instructions before assembling the lounge.
- For your safety and ease, assembly by two or more adults is recommended.
- Keep instructions for future use.

Pre-assembly:







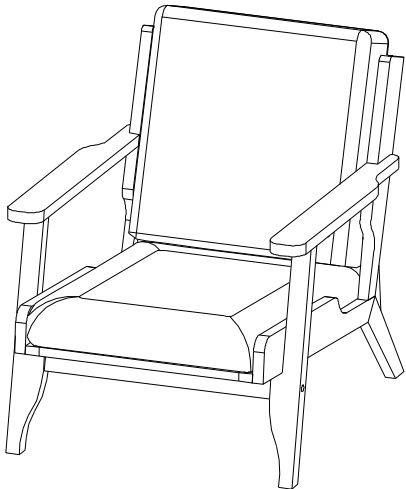

- Do not discard any contents until after assembly is complete to avoid accidentally discarding small parts or hardware.
- Remove all parts and hardware from box along with any plastic protective packaging.

Parts List

Item	Description	QTY
A	Right Arm 	1
B	Left Arm 	1
C	Seat Cushion 	1
D	Back Cushion 	1
E	Seat Frame 	1
F	Back Frame 	1
G	Stretcher 	1



Hardware List

Item	Description	QTY
a	Bolts Ø1/4"x3" 	2
b	Bolts Ø1/4"x2" 	10
c	Lock Washers 1/4" 	12
d	Big flat washers 1/4" (19mm) 	10
e	Small flat washers 1/4" (12mm) 	2
f	Allen Wrench 1/4" 	1
g	Wooden Plugs 	2
h	Open Wrench 	1

Assembly Procedures:

Step 1. Assemble the lounge on a flat, soft surface such as a carpet or cloth to prevent scratching the finish. Attach seat frame (E) and back frame (F) to the left arm (B) using bolts (b), lock washers (c) and flat washers (d). Loosely tighten the bolts with Allen wrench (h).

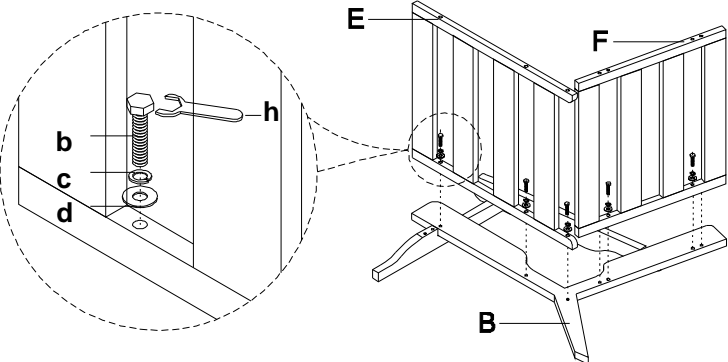

Step 2. Attach stretcher (G) to the left arm (B) using bolt (a), lock washer (c) and flat washer (e). Loosely tighten the bolt with Allen wrench (f).

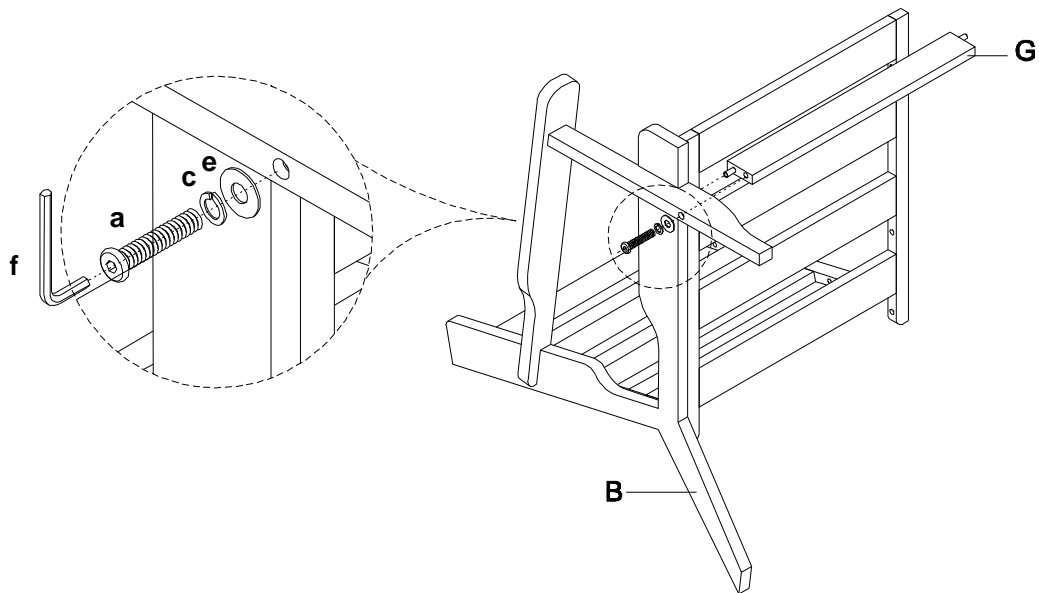

Step 3. Attach right arm (A) to the assembled seat frame (E), back frame (F) and stretcher (G) using bolts (b), lock washers (c) and flat washers (d). Loosely tighten the bolts with open wrench (h) as shown below.

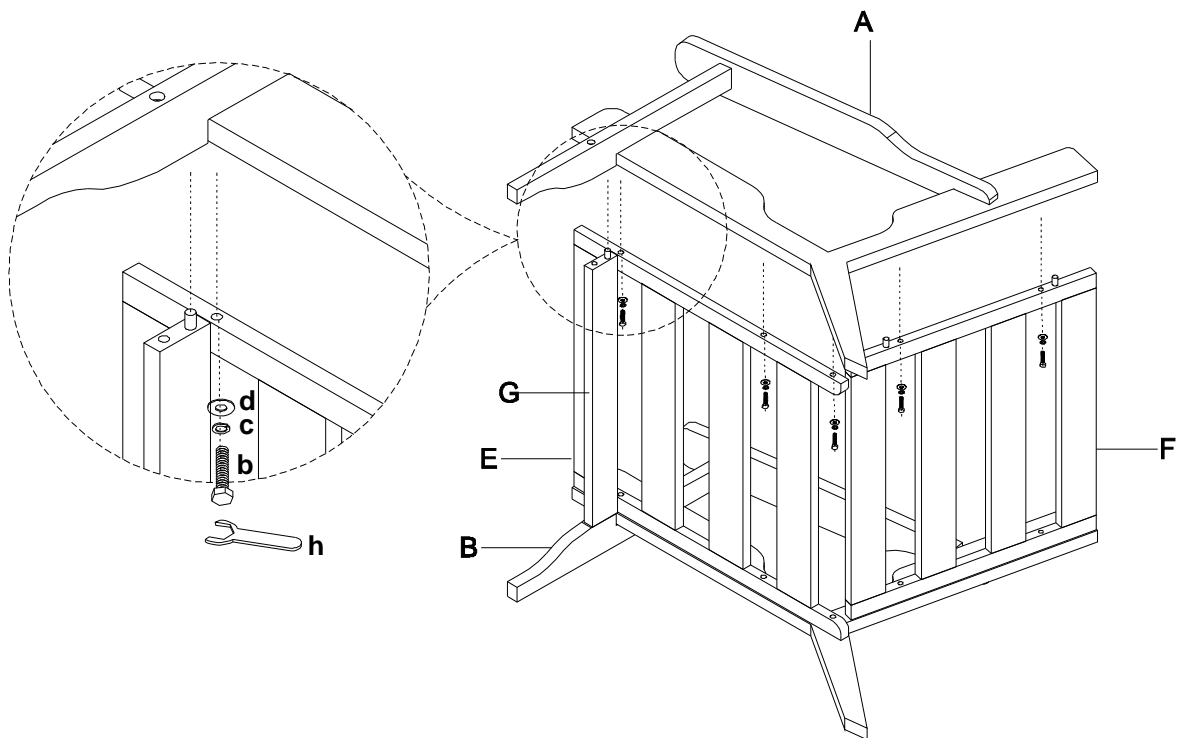

Step 4. Attach right arm (A) to stretcher (G) using bolt (a), lock washer (c) and flat washer (e). Loosely tighten the bolt with Allen wrench (f).

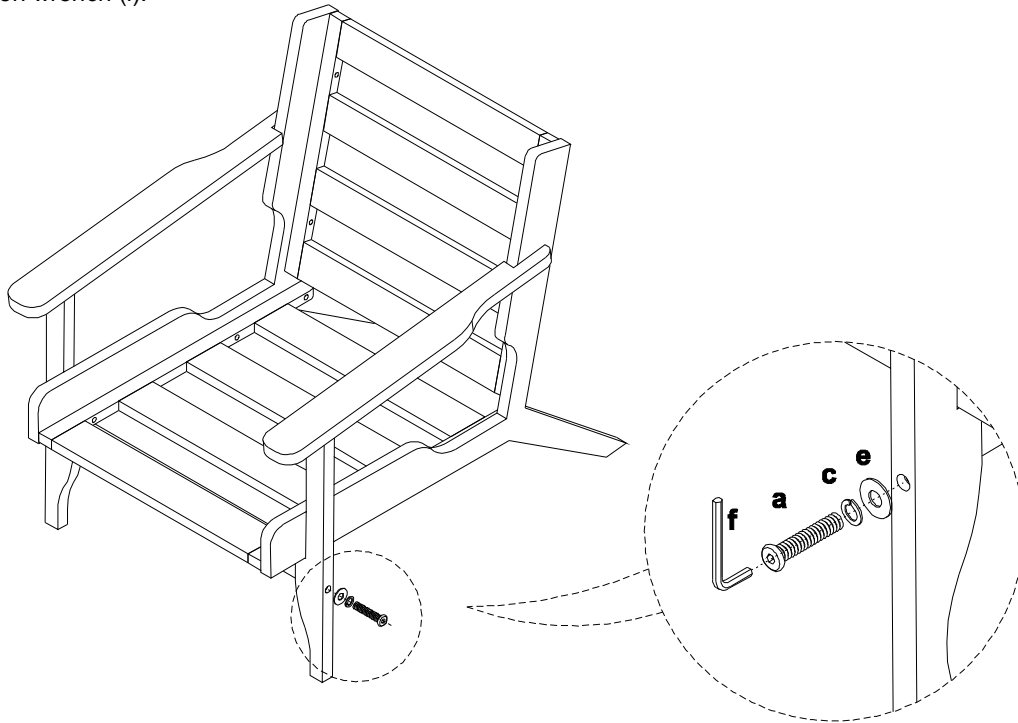

Step 5. Turn the assembled lounge to an upright position. Securely tighten all bolts with wrenches (f, h), but do not over tighten the bolts.

- 1) Attach wooden plugs (g) to each bolt hole, tighten with rubber hammer to knock the wooden plug till its tight.
Note: use a soft cloth between the wooden plug and hammer to prevent damage to wooden plug finish.
- 2) Assembly is complete. Failure to follow these instructions may cause the bolts to misalign during assembly.
- 3) Put the seat cushion (C) and back cushion(D) on the assembled lounge.

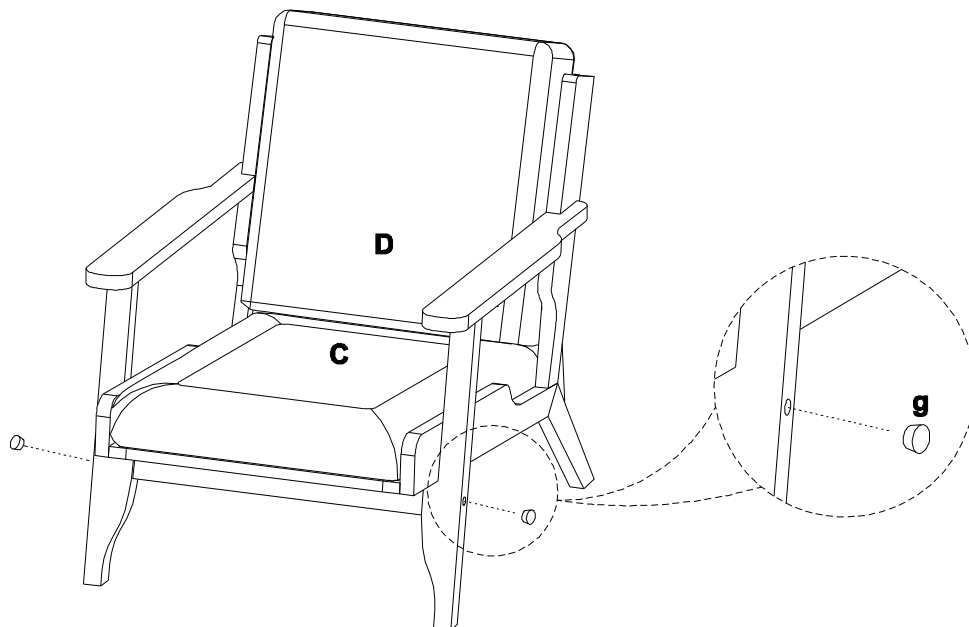

ADDITIONAL NOTE ABOUT SAFETY: BOLTS MAY LOOSEN DURING NORMAL EVERYDAY USE. THEY SHOULD BE PERIODICALLY INSPECTED AND RE-TIGHTENED TO PREVENT DAMAGE OR INJURY. ALWAYS CHECK TO BE SURE THAT ALL HARDWARE IS KEPT TIGHTENED.

Thank you for your purchase