

# ASSEMBLY INSTRUCTIONS

Description: Douglas Accent Chair









**Important safety instructions:**

- Please read carefully all instructions before assembly.
- For your safety and ease, assembly by two or more adults is recommended.
- Keep instructions for future use.

**Pre-assembly:**







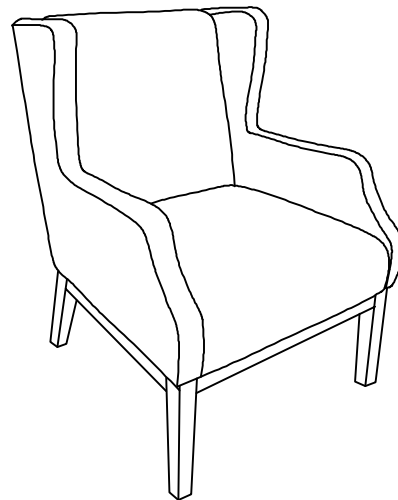

- Do not discard any content until assembly is complete to avoid accidentally discarding small parts or hardware.
- Take out all parts and hardware from box.

**Parts List**

Item	Description	QTY
P1	Back Cushion 	1
P2	Seat Cushion 	1
P3	Front Legs 	2
P4	Left Back Leg  P4	1
P5	Right Back Leg  P5	1
P6	Left Arm  P6	1
P7	Right Arm  P7	1
P8	Seat Frame 	1



**Hardware List**

Item	Description	QTY
H1	Short Bolts Ø1/4"*1-1/2"L 	12
H2	Medium Bolts Ø1/4"*2-1/2"L 	8
H3	Long Bolts Ø1/4"*2-3/4"L 	4
H4	Lock Washers 1/4" 	24
H5	Flat Washers 1/4"*19mm 	20
H6	Flat Washers 1/4"*12mm 	4
H7	Allen Wrench 1/4" 	1
H8	Screws 8*1-3/4" 	4
H9	Screw Driver 	Not included

### Assembly Procedures:

Step 1. Assemble the chair on a flat, soft surface such as a carpet or cloth to prevent scratching the finish. Attach the seat cushion (P2) to the back cushion (P1) as shown below.

- (H1)x2 Bolts  $\varnothing 1/4'' \times 1-1/2''$  
- (H4)x2 Lock Washers 1/4" 
- (H5)x2 Flat Washers 1/4''x19mm 
- (H7)x1 Allen Wrench 1/4" 

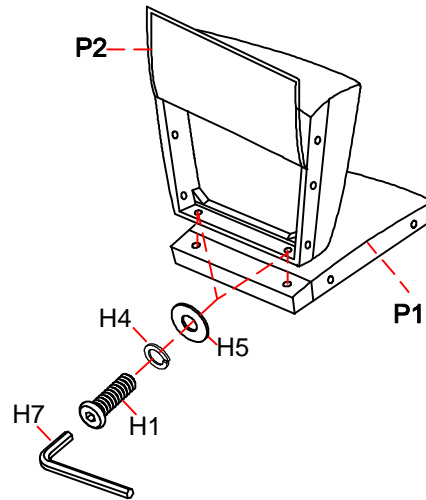

Step 2. Loosely attach the left arm (P6) and the right arm (P7) to the assembled seat cushion (P2) as shown below.

- (H1)x6 Bolts  $\varnothing 1/4'' \times 1-1/2''$  
- (H4)x6 Lock Washers 1/4" 
- (H5)x6 Flat Washers 1/4''x19mm 
- (H7)x1 Allen Wrench 1/4" 

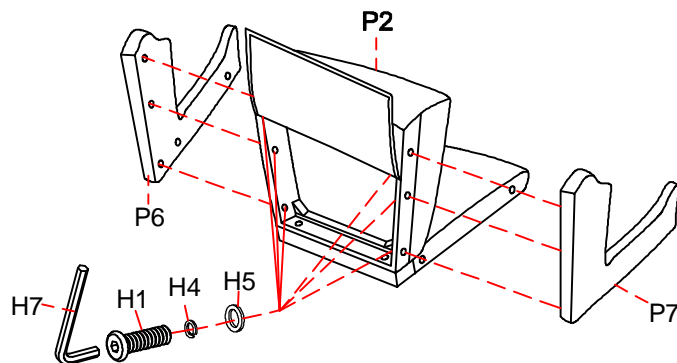

Step 3. Attach the left arm (P6) and the right arm (P7) to the assembled back cushion (P1) as shown below.

- (H1)x4 Bolts  $\varnothing 1/4'' \times 1-1/2''$  
- (H4)x4 Lock Washers 1/4" 
- (H5)x4 Flat Washers 1/4''x19mm 
- (H7)x1 Allen Wrench 1/4" 

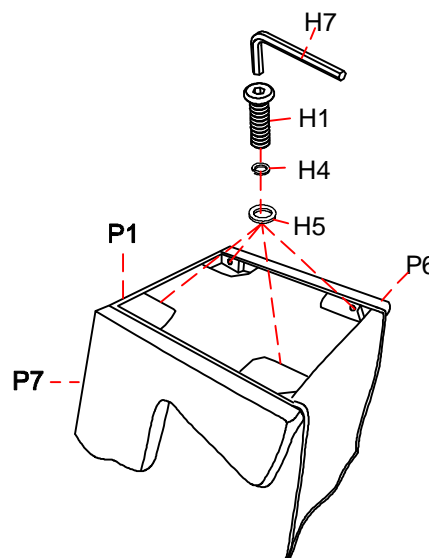

Step 4. Attach the seat frame (P8) to the bottom of the assembled arms (P6&P7) and seat cushion (P2) and back cushion (P1) as shown below.

- (H3)x4 Long Bolts  $\text{\O}1/4'' \times 2-3/4'' \text{L}$  
- (H4)x4 Lock Washers 1/4" 
- (H6)x4 Flat Washers 1/4" x 12mm 
- (H7)x1 Allen Wrench 1/4" 
- (H8)x4 Screws 8 x 1-3/4" 

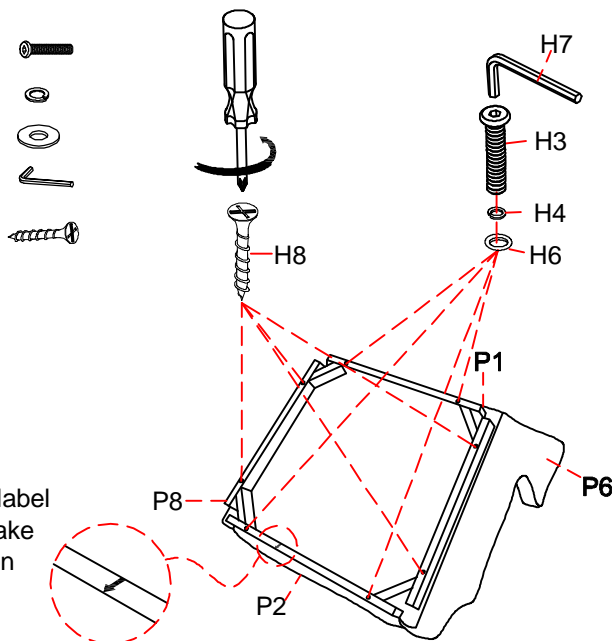

Note: There is arrow label on the seat frame, make sure the seat frame on right position.

Step 5. Attach the front legs (P3) and the left back leg (P4) and the right back leg (P5) to the assembled seat frame (P8) as shown below.

- (H2)x8 Bolts  $\text{\O}1/4'' \times 2-1/2'' \text{L}$  
- (H4)x8 Lock Washers 1/4" 
- (H5)x8 Flat Washers 1/4" x 19mm 
- (H7)x1 Allen Wrench 1/4" 

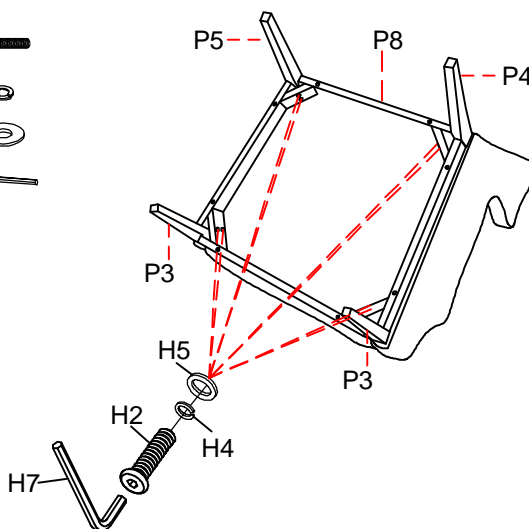

Step 6. Turn the assembled chair to an upright position. Make sure the chair is level and securely tighten all bolts with Allen wrench (H7). Assembly is complete. **Failure to follow these instructions may cause the bolts to misalign during assembly.**

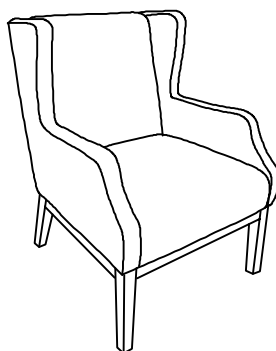

ADDITIONAL NOTE ABOUT SAFETY: BOLTS MAY LOOSEN DURING NORMAL EVERYDAY USE. THEY SHOULD BE PERIODICALLY INSPECTED AND RE-TIGHTENED TO PREVENT DAMAGE OR INJURY. ALWAYS CHECK TO BE SURE THAT ALL HARDWARE IS KEPT TIGHTENED.

Thank you for your purchase