

# Item # : IVYL1K

## Assembly Instructions

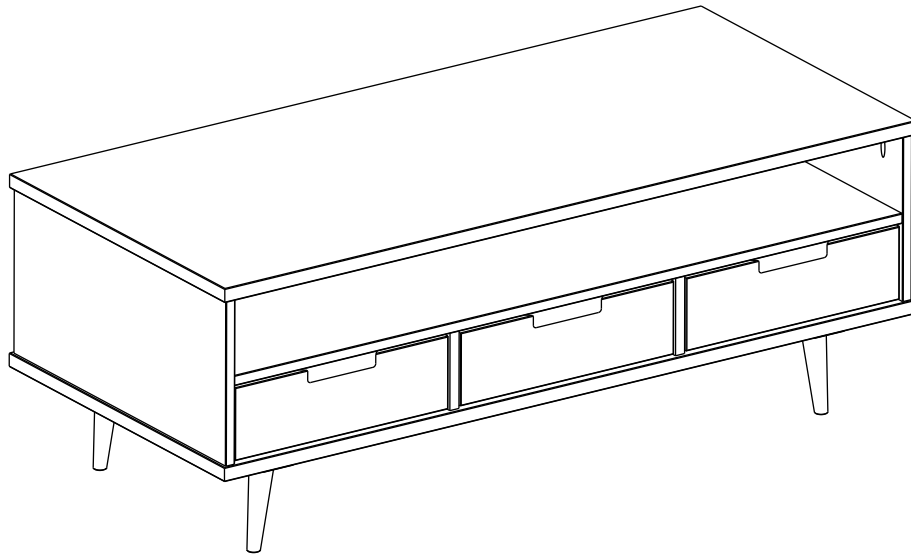

Please visit our website for the most current instructions, assembly tips, report damage, or request parts. [www.walkeredison.com](http://www.walkeredison.com)

Revised 08/2022

# General Assembly Guidelines

- I. Ensure that all parts and hardware are available before beginning assembly.
- II. Follow each step carefully to ensure the proper assembly of this product.
- III. Two people are recommended for ease in the assembly of this product.
- IV. The three main types of hardware used to assemble this product are wood dowels, screws and bolts.
- V. The provided glue is to secure wood dowels in place . When first inserting dowels , locate the appropriate hole for the dowel , place a small amount of glue in the hole and insert the dowel . Wipe away excess glue immediately.

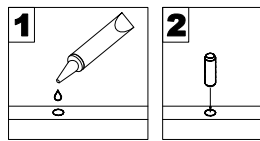

In future assembly steps when dowels are necessary to attach assembly parts together , place a small amount of glue on the end of the dowel before attaching parts together . Wipe away excess glue immediately.

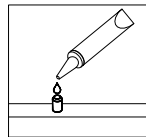

- VI. A Phillips head screwdriver is required for the assembly of this product.

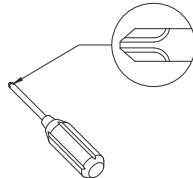

- VII. Power tools should not be used to assemble this product.

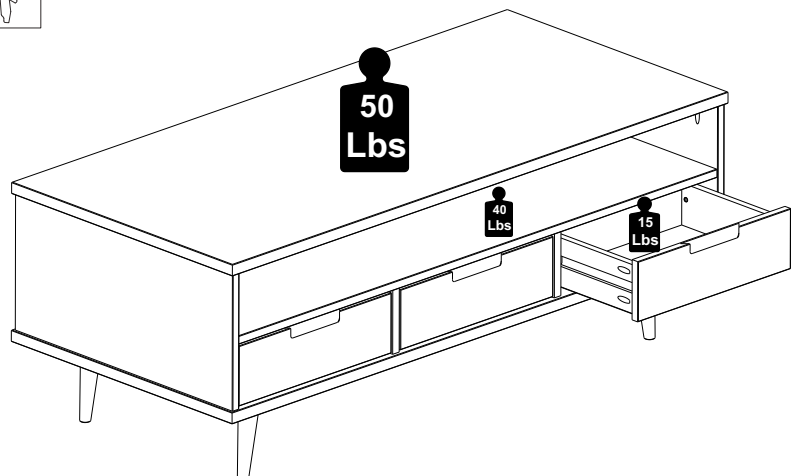
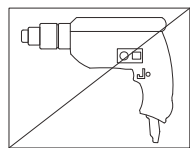

# Parts List

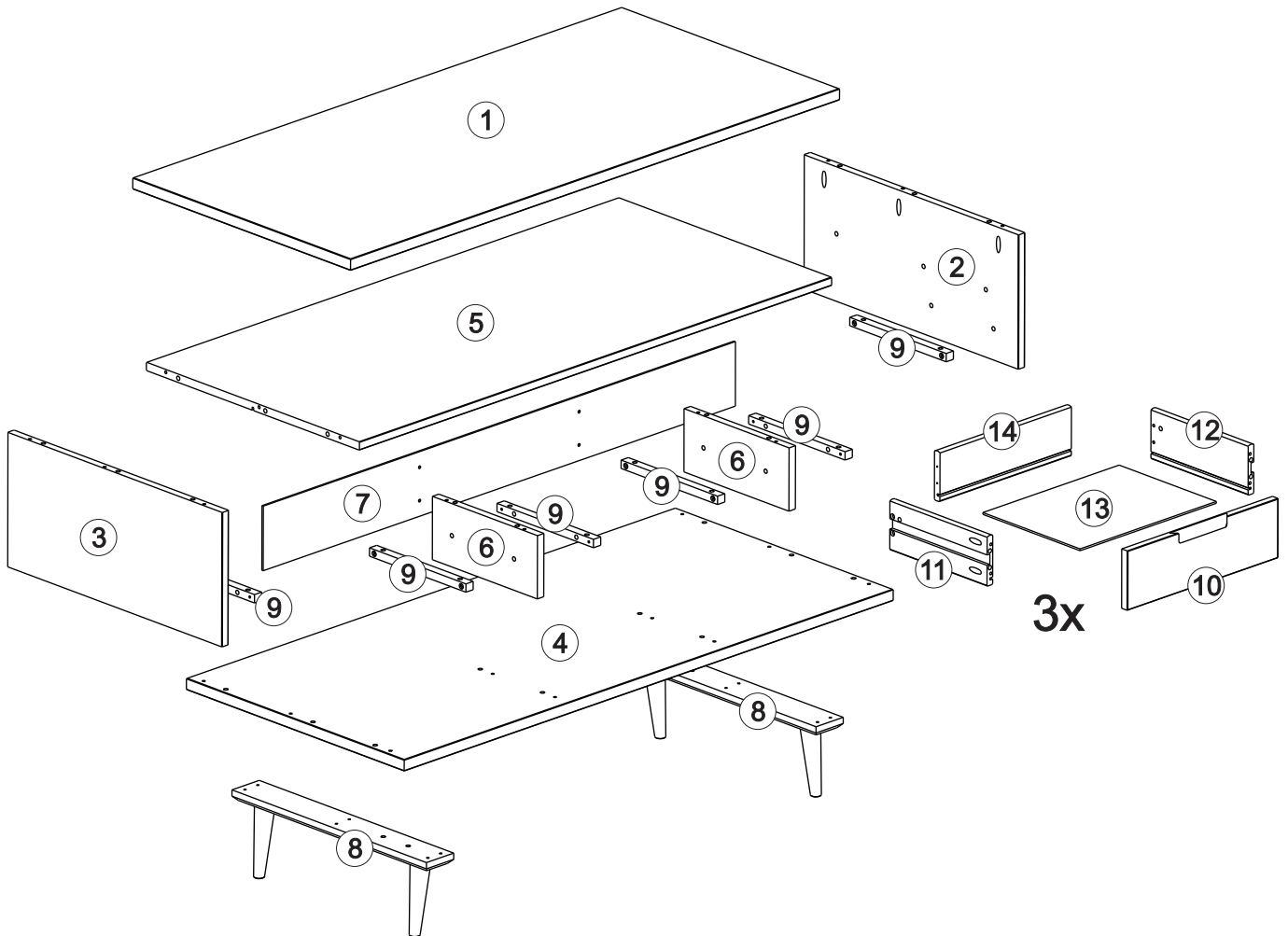

Part#	Description	Qty
1	Top panel	01
2	Right side panel	01
3	Left side panel	01
4	Botom panel	01
5	Shelf	01
6	Division	02
7	Back panel	01

Part#	Description	Qty
8	Foot	02
9	Drawer runner	06
10	Drawer Front	03
11	Left dawer side	03
12	Right drawer side	03
13	Drawer botom	03
14	Drawer back	03

# Hardware List

A		Ø8*30mm	Wood dowel	54 pcs
B		Ø8*20mm	Wood dowel	12 pcs
C		Ø4,0*25mm	Screw	12 pcs
D		Ø3,5*30mm	Screw	40 pcs
E		Ø4,0*40mm	Screw	22 pcs
F		Ø3,5*14mm	Screw	04 pcs
G			Glue	01 pcs

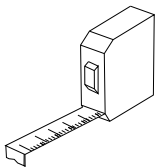

Tape measure and hammer  
recommended for assembly  
(not included)

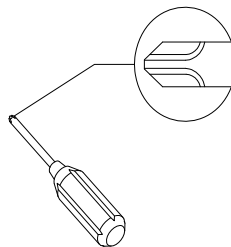
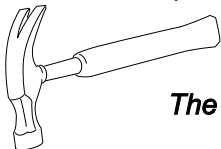



Philips head screwdriver  
required for assembly  
(not included)

*The hardware quantities listed above are required for proper assembly.  
Some extra hardware may also have been included.*

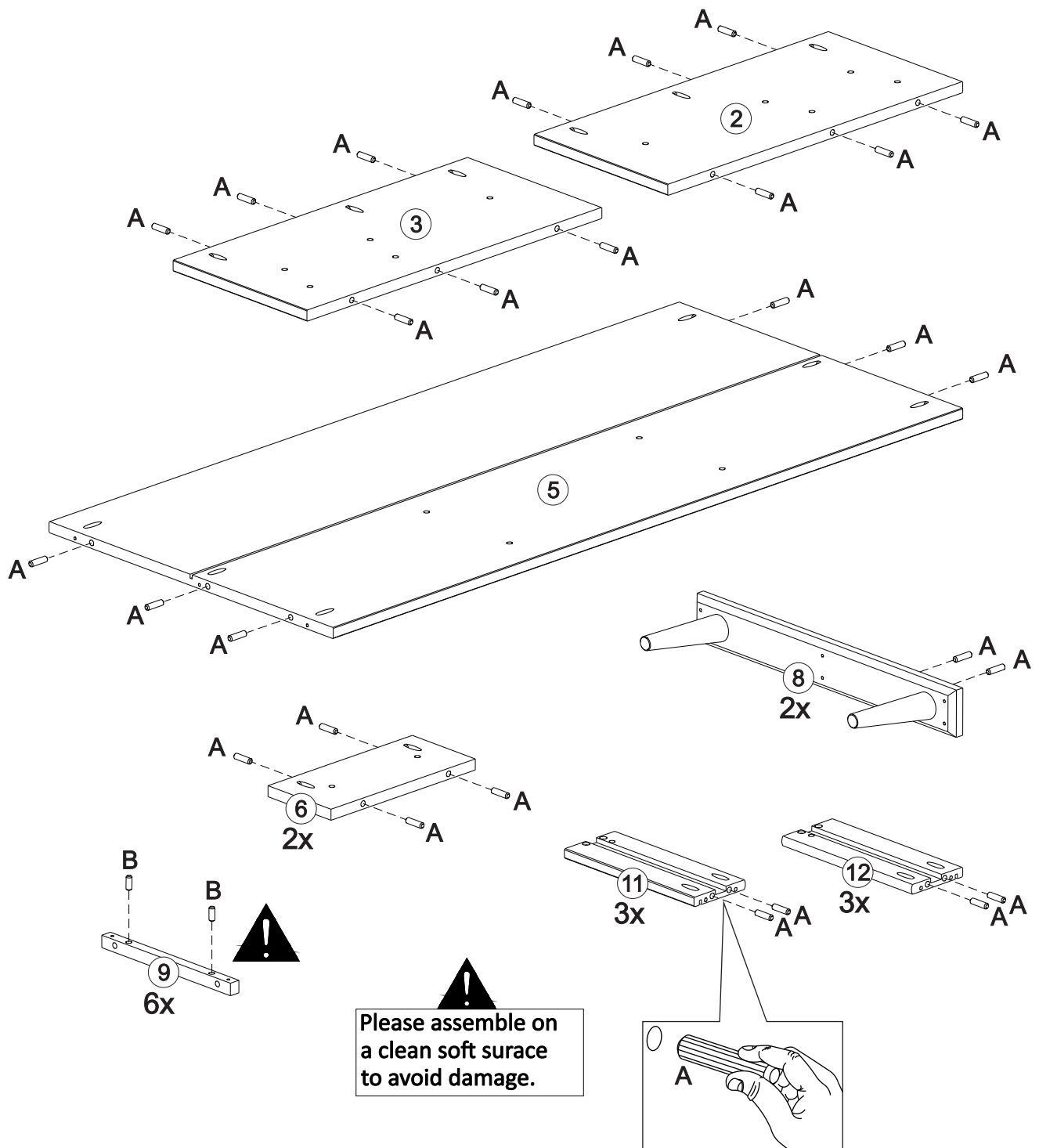
# Step 1

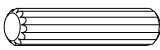

! Please assemble on a clean soft surface to avoid damage.

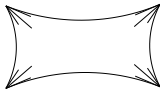
A	 Ø8*30mm	42
B	 Ø8*20mm	12
G		01

Insert wood dowel (A) and glue (G) into parts (2,3,5,6,8,11,12).  
Insert wood dowel (B) and glue (G) into part (9).

## Step 2

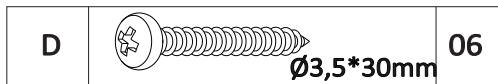
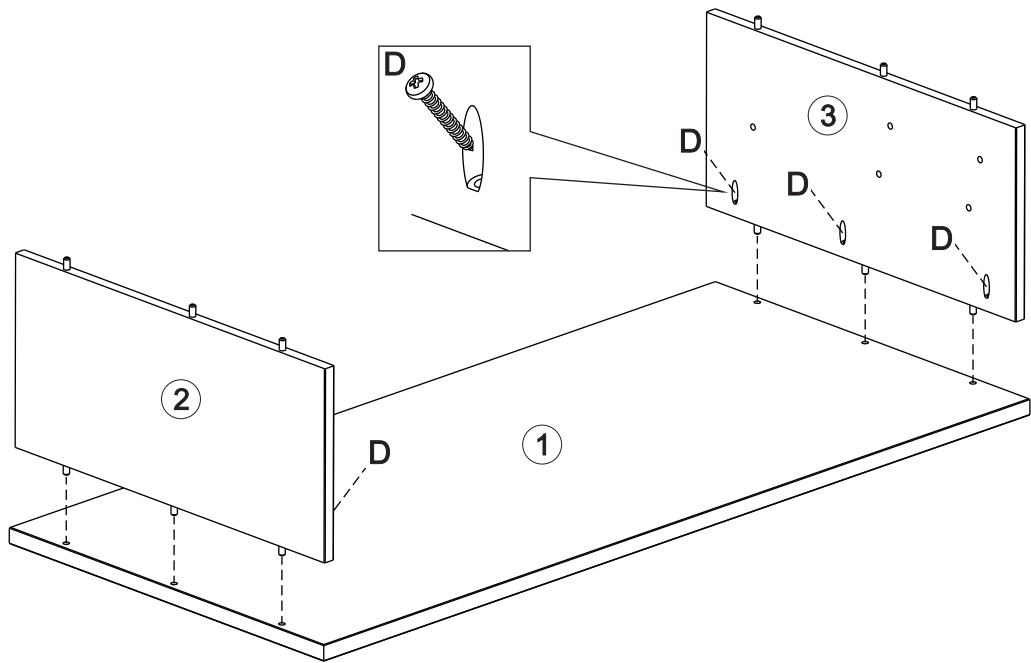

Fix to parts (2,3) to part (1) using screw (D)

## Step 3

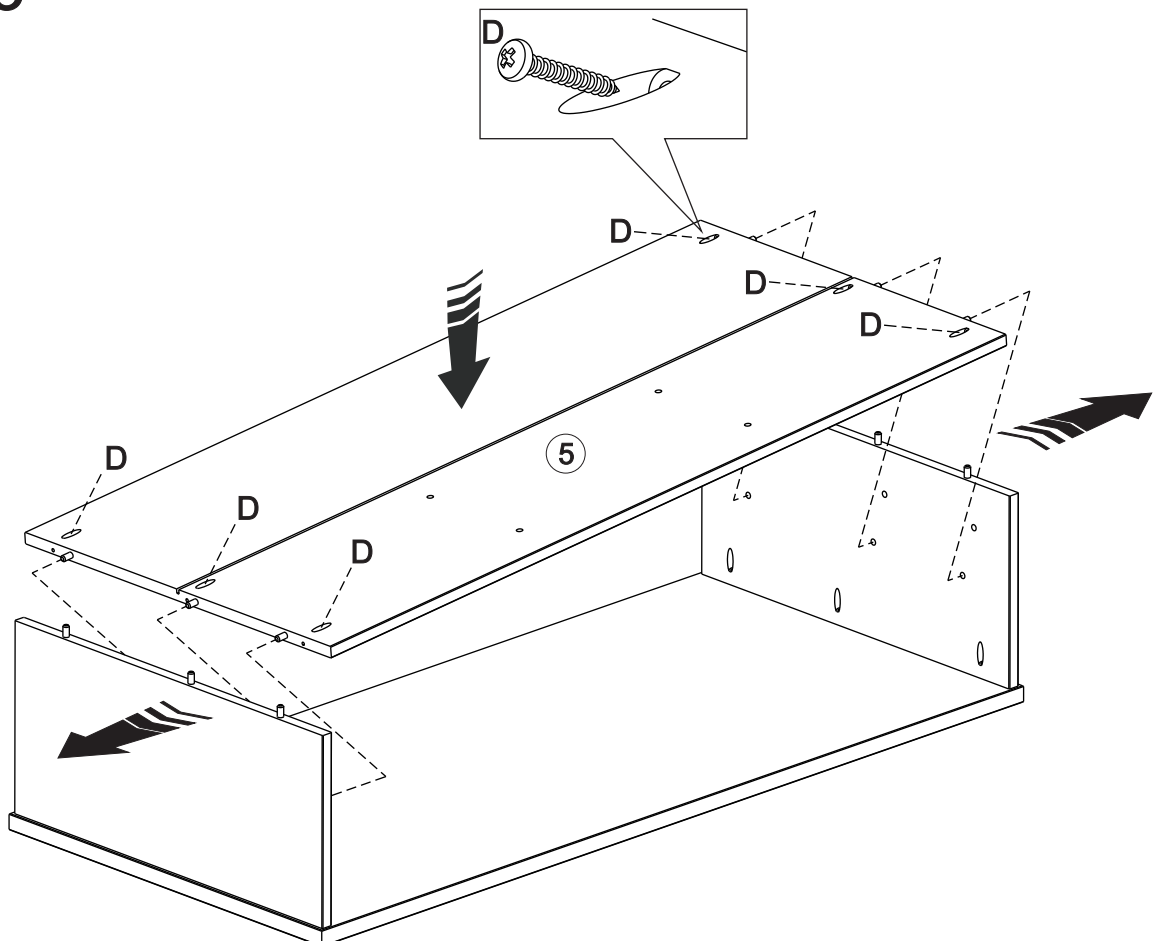

Attach part (5) to parts (2,3) using screw (D)

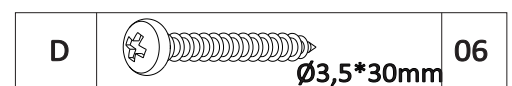

# Step 4

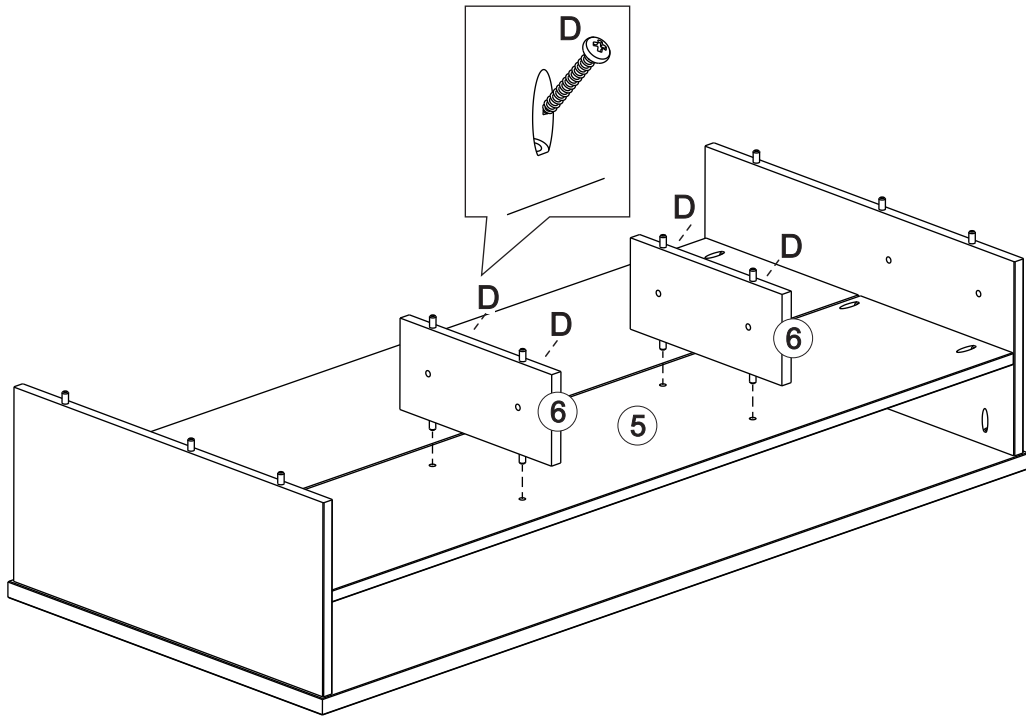

Fix the part (6) to the part (5) using the screw (D)

D		04
$\text{Ø}3,5*30\text{mm}$		

# Step 5

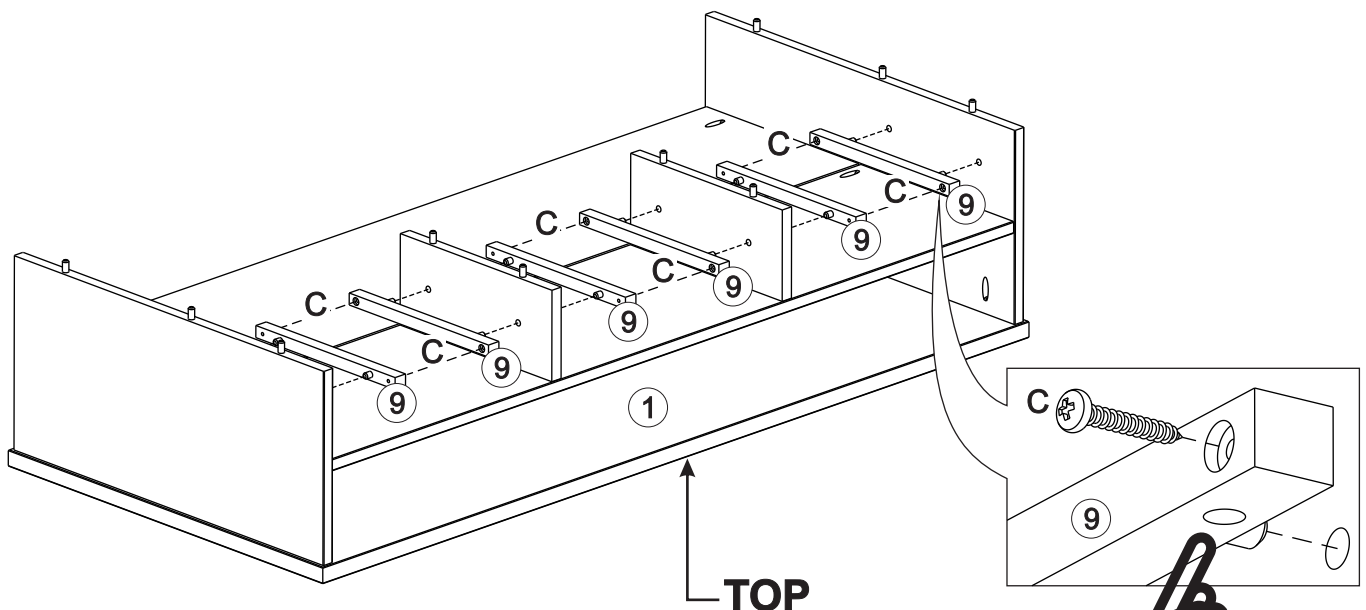

Use screw (C) to secure parts (9) to parts (2, 3) and BOTH sides of parts (6)

NOTE: The extra holes in the part (9) must face the top of the part (2, 3, 6)

C		12
$\text{Ø}4,0*25\text{mm}$		

# Step 6

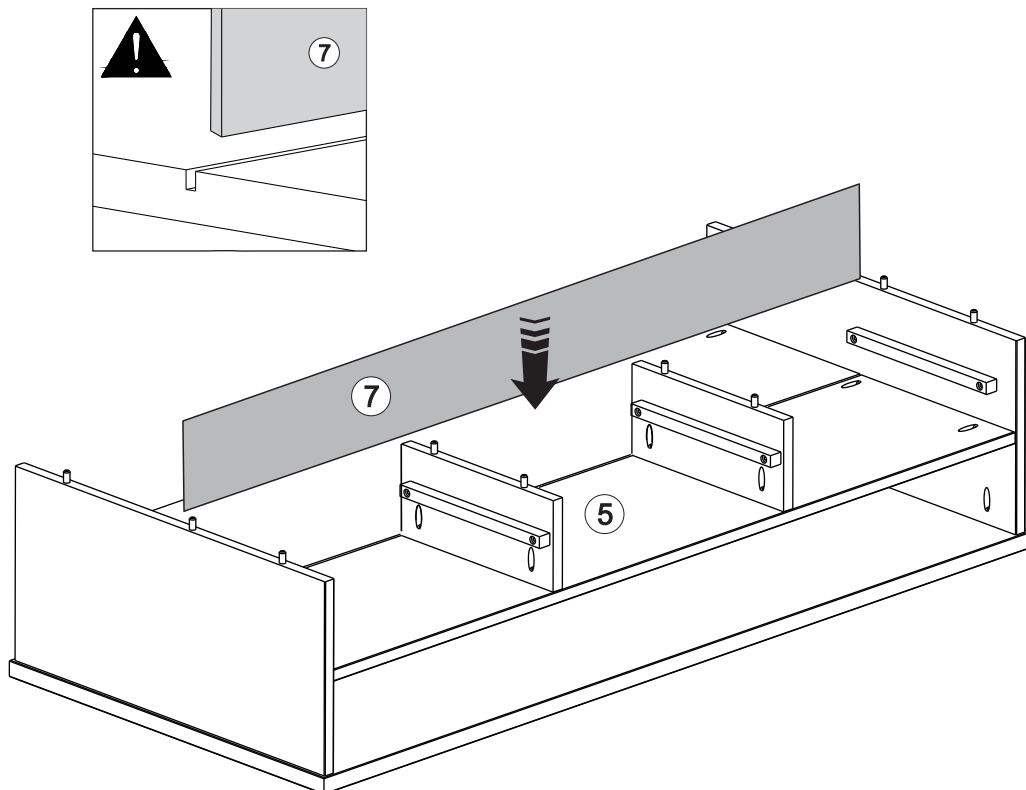

Insert part (7) into filister in the part (5)

# Step 7

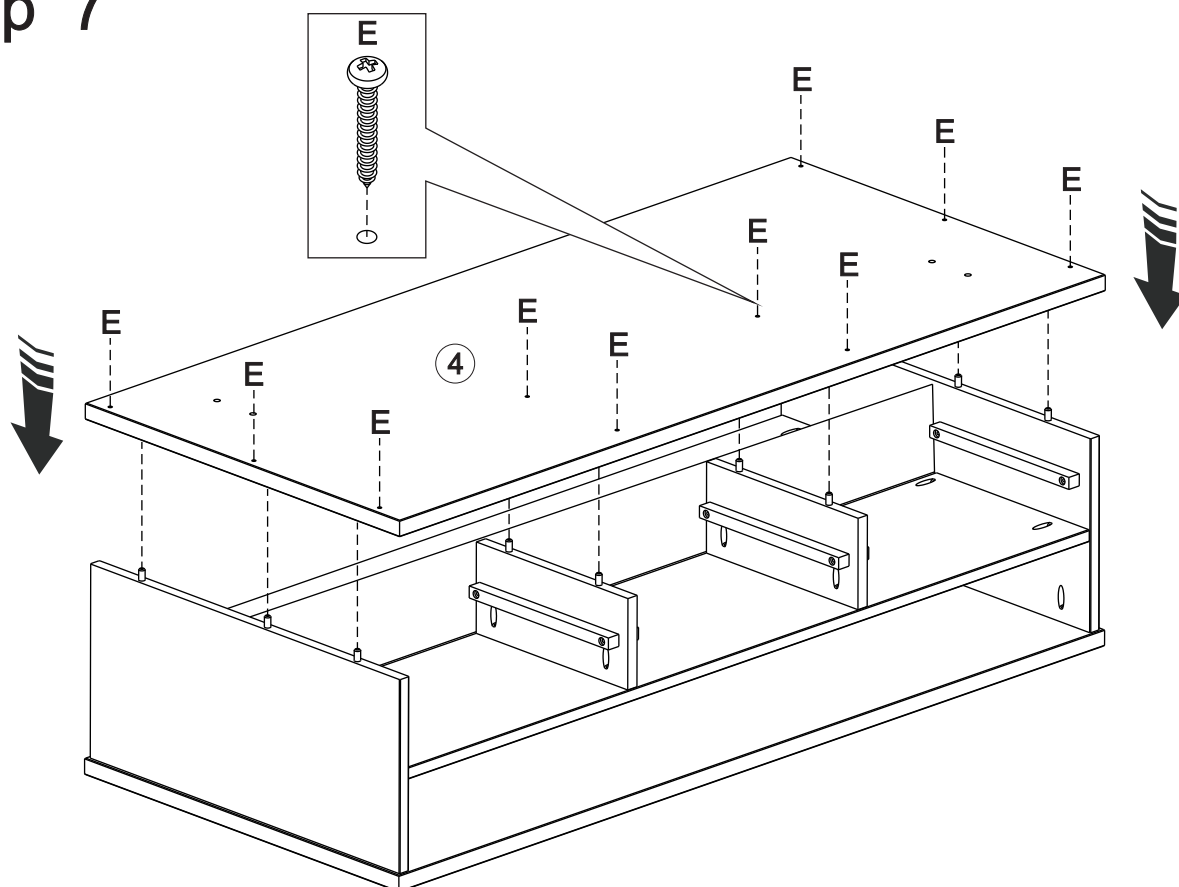

Atach part (4) to body with screws (E)

E		10
		Ø4,0*40mm



# Step 8

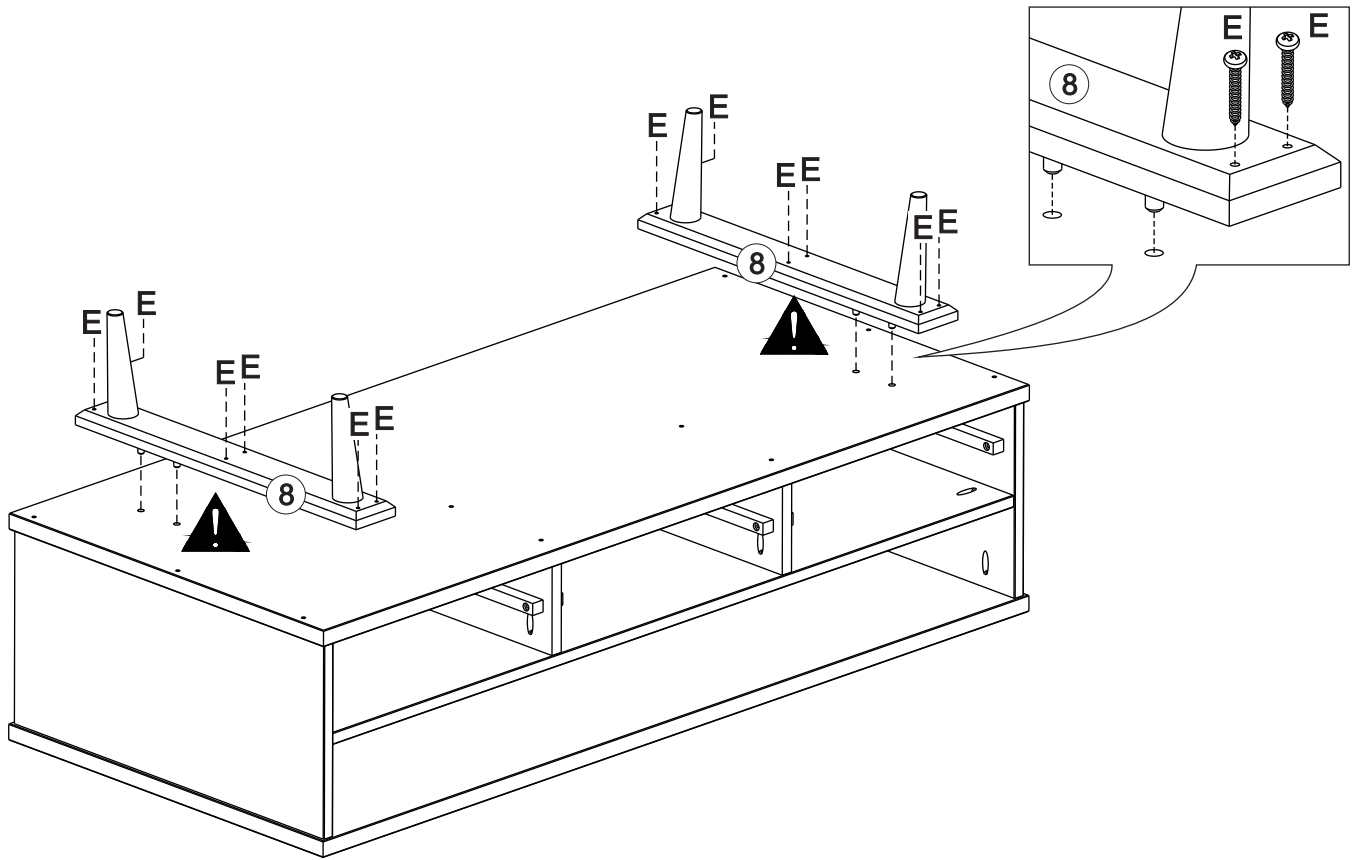

Attach part (8) to body with screws (E)

E		12
$\text{Ø}4,0*40\text{mm}$		

# Step 9

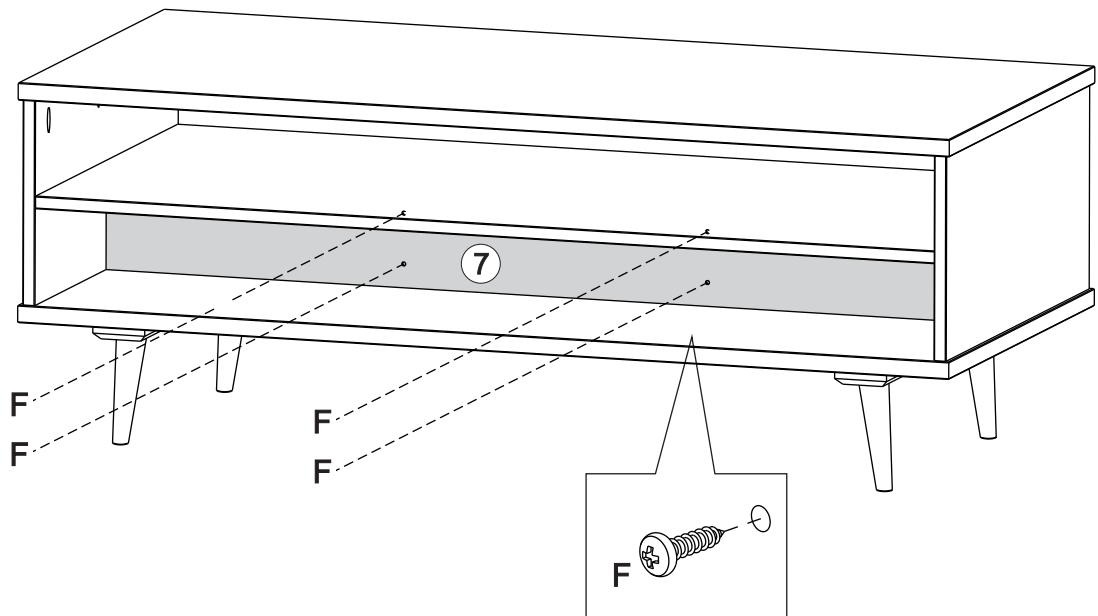

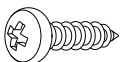
F		04
$\text{Ø}3,5*14\text{mm}$		

Fix the part 7 into holes with a screw (F)

# Step 10

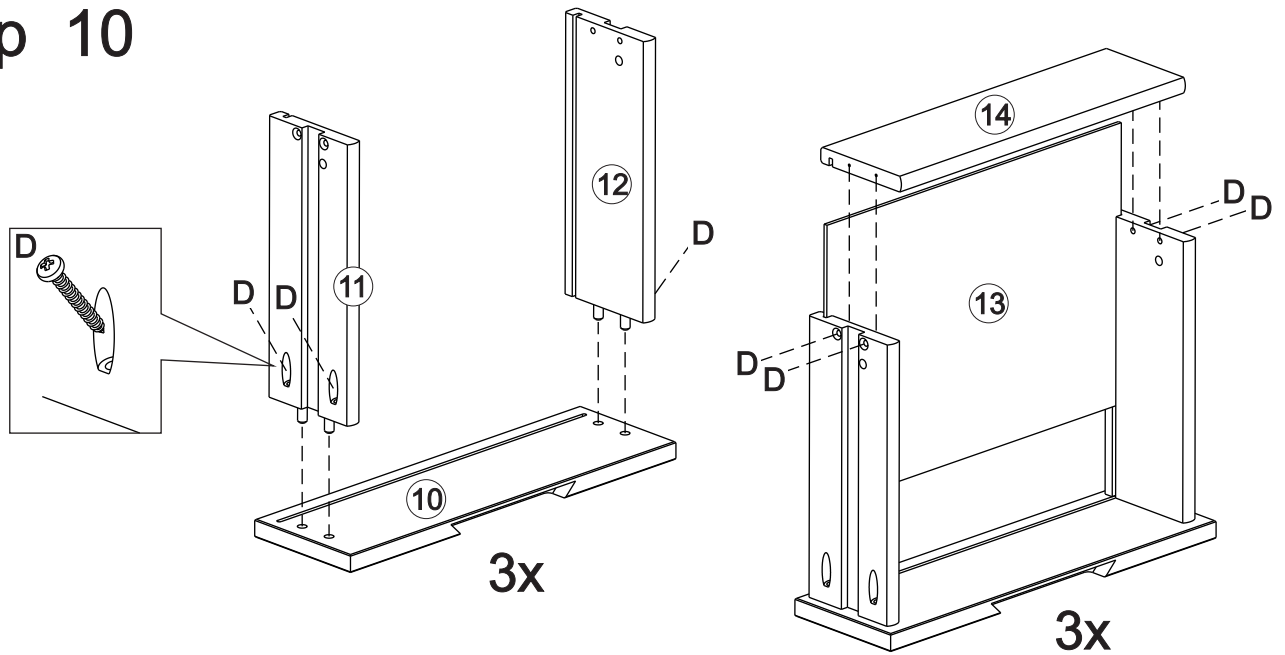

Attach parts (11,12) to part (10), insert panel (13) into groves and secure part (14) with screws(D).

D		24
		Ø3,5*30mm

# Step 11

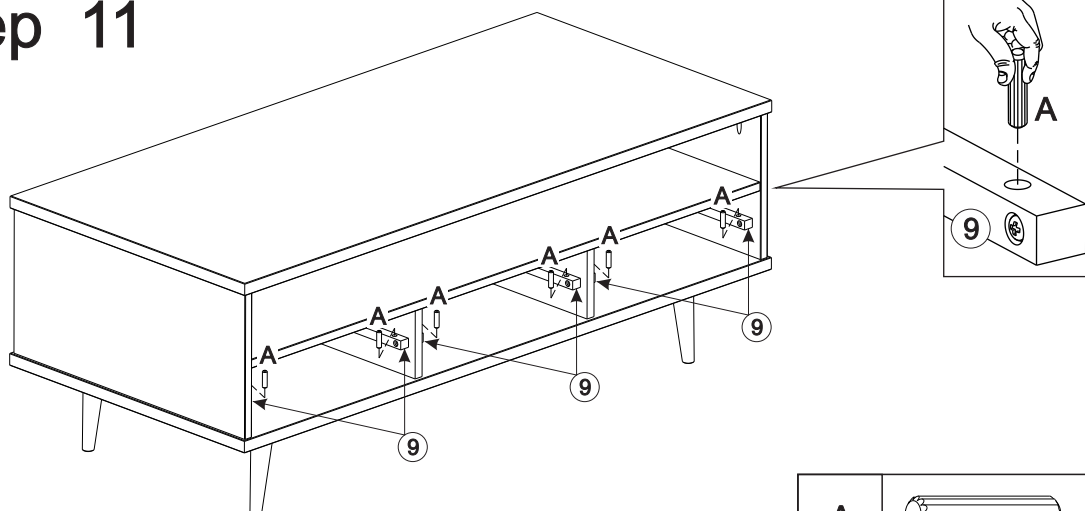

Insert wood dowel (A) into the front hole in the drawer rails (9)

A		06
		Ø8*30mm

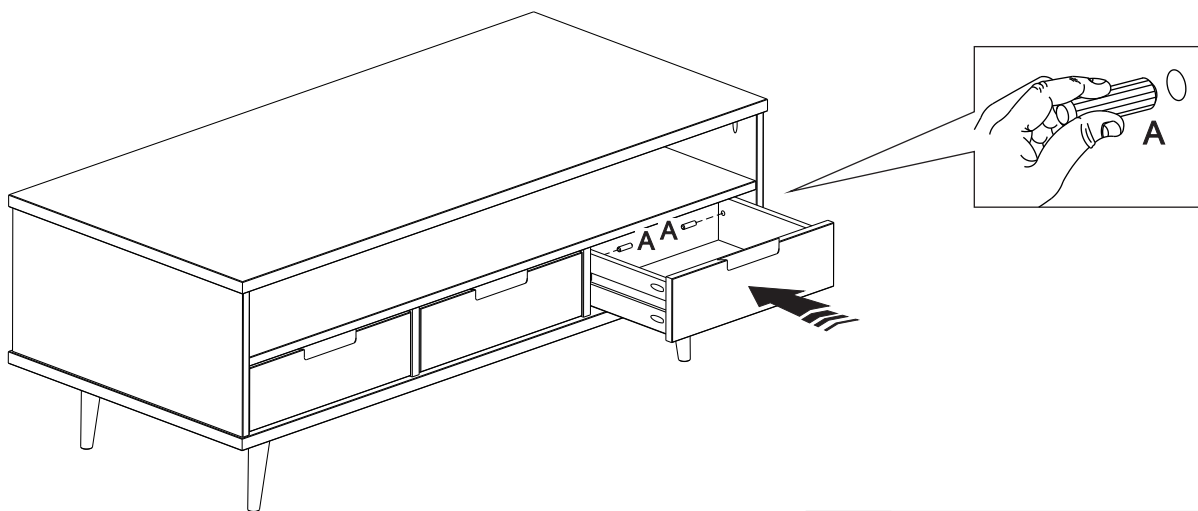

Insert the wood dowel (A) into the inside the drawer while drawers is inside the unit. Make sure the pin is flush with the panel.

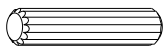
A		06
		Ø8*30mm

**Assembly Complete!**