

ASSEMBLY INSTRUCTION

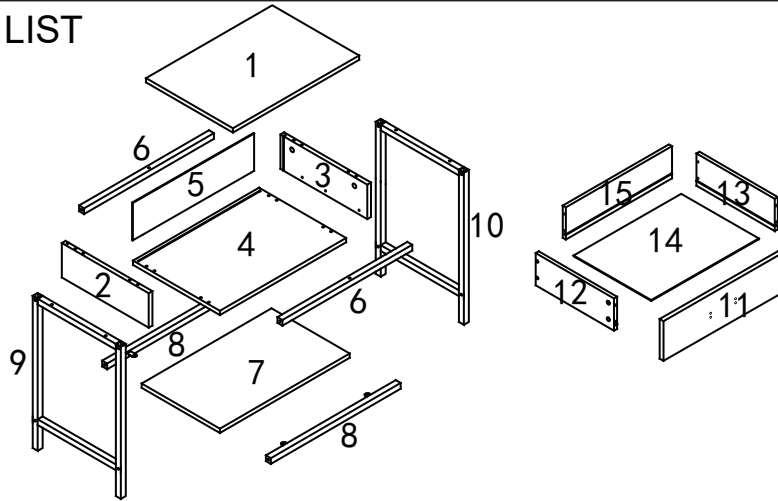







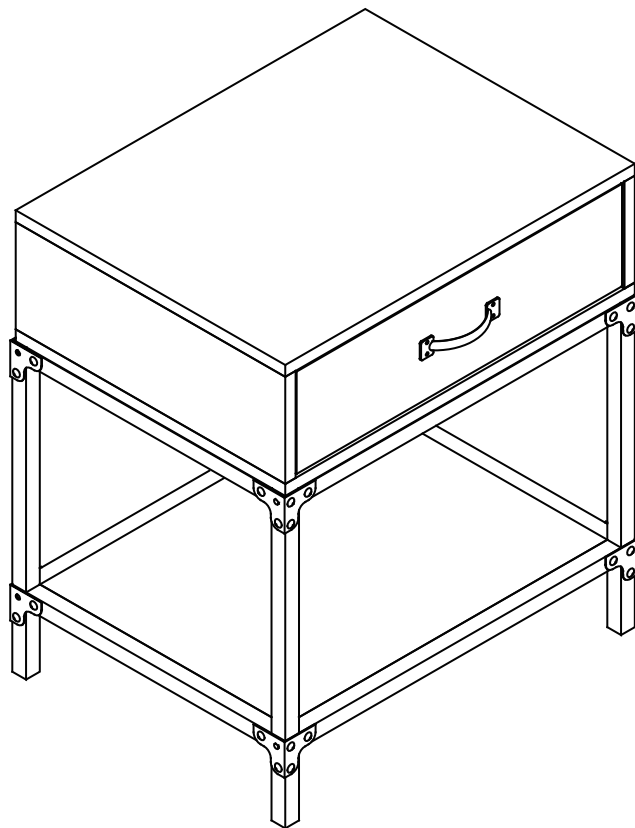







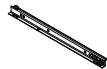

PART LIST



- | | |
|------------------------|-------------------------|
| 1: top panel | 2: drawer left panel |
| 3: drawer right panel | 4: bottom panel |
| 5: back panel | 6: support metal tube |
| 7: shelf panel | 8: shelf metal tube |
| 9: left leg | 10: right leg |
| 11: drawer front panel | 12: drawer left panel |
| 13: drawer right panel | 14: drawer bottom panel |
| 15: drawer back panel | |

HARDWARE LIST



- | | | | | |
|---|---|---|---|---|
|  |  |  |  |  |
| A x 8
wooden dowel | B x 14
screw
D4X35mm | C x 8
cam lock pin | D x 8
cam lock | E x 12
screw
D3.5X14mm |
|  |  |  |  |  |
| F x 1
left drawer rail | G x 1
right drawer rail | H x 1
left drawer slider | I x 1
right drawer slider | J x 4
screw
D4X14mm |
|  |  |  |  |  |
| K x 1
handle | L x 4
screw
D3x12mm | M x 4
metal decoration | N x 4
metal decoration | O x 8
bolt
D6x35mm |
|  |  |  | | |
| P x 1
hex wrench | Q x 4
plastic fixer | R x 4
screw
D3x14mm | | |

01

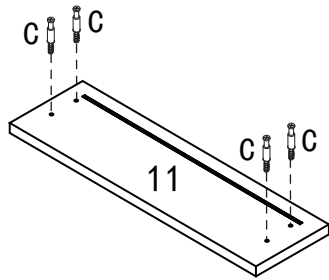

Screw 4pcs Cam lock pin (C) to drawer front panel(11) as shown.

02

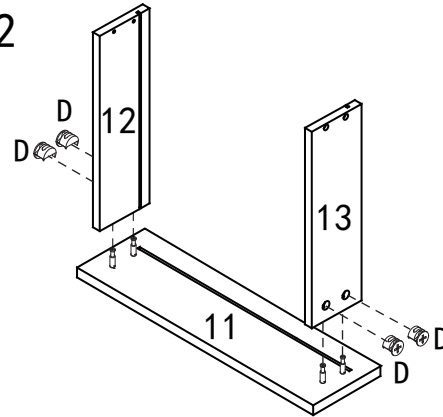

Put cam lock(D) in drawer left and right panel(12,13) and lock them on drawer front board (11) as shown.

03

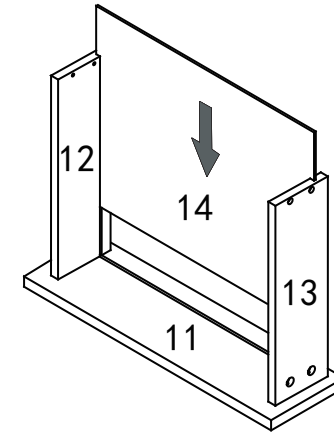

Insert drawer bottom panel(14).

04

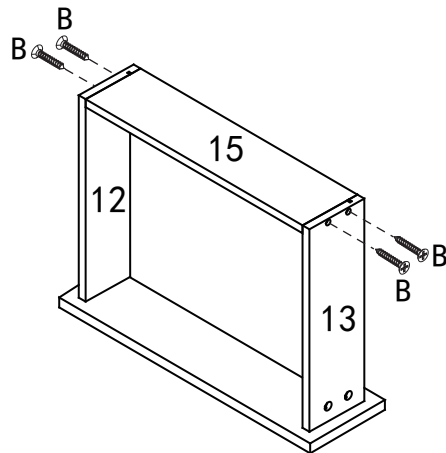

Fix drawer back panel(15) to left and right drawer panels(12,13) with 4pc screw(B).

05

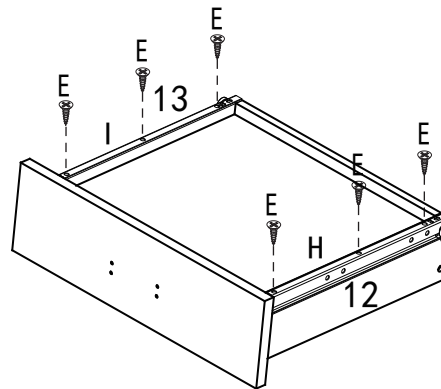

Use screw (E) to fix left and right drawer slider (H/I) to drawer left and right panels(12,13) .

06

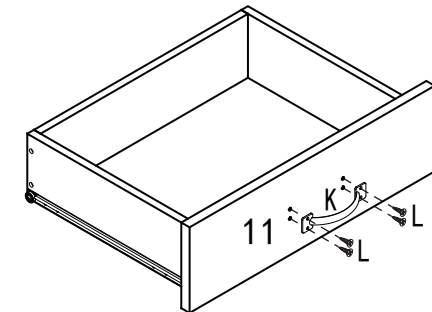

Fix handle(K) with screw(L) .

07

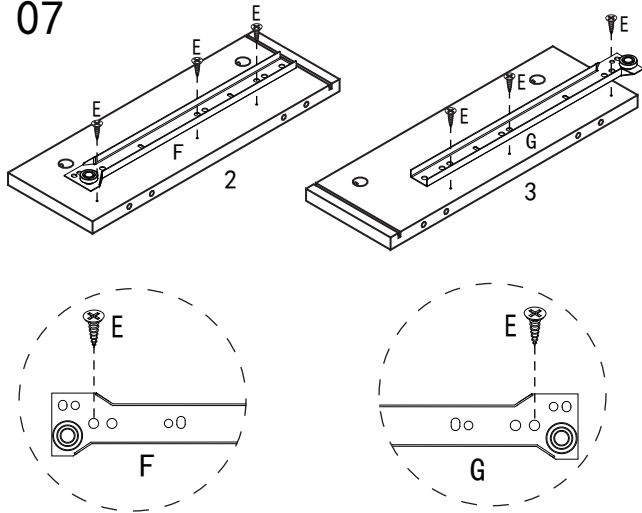

Use screw(E) to fix left drawer rail (F) on drawer left panel(2) and fix right drawer rail(G) on drawer right panel(3).

08

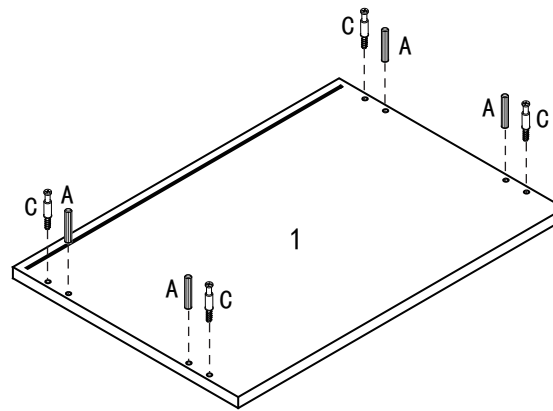

Screw 4 pc cam lock pin(C) on top panel(1), and insert 4pc wooden dowel(A).

09

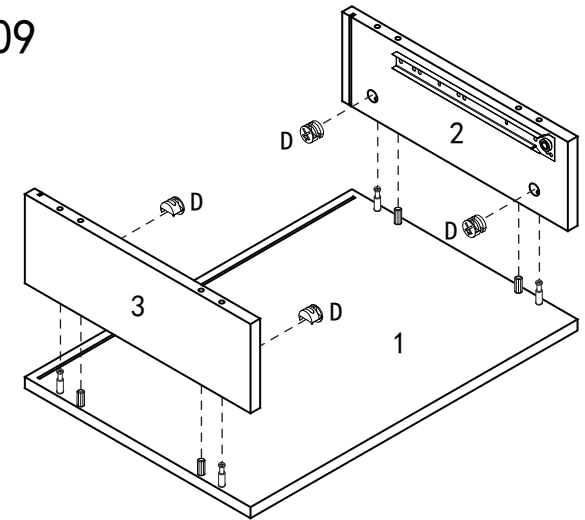

Put 4pc cam lock(D) inside the hole and fix drawer left and right panels with top panel.

10

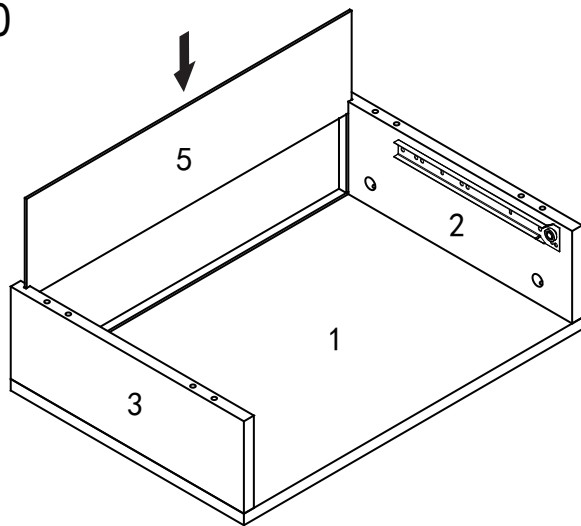

Insert drawer back panel(5).

11

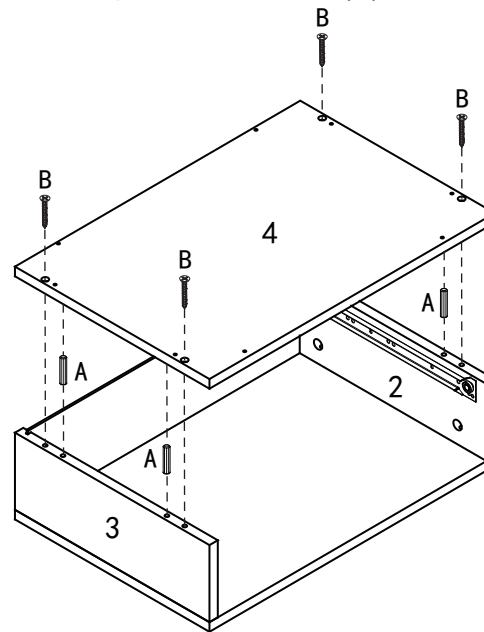

Insert 4pc wooden dowel on drawer right and left panels(2,3), and use 4pc screws(B) to fix bottom panel(4) to (2,3) .

12

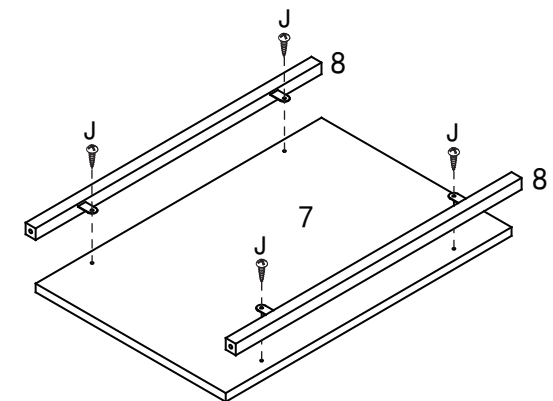

Use screw (J) to fix shelf metal tube(8) to shelf panel(7).

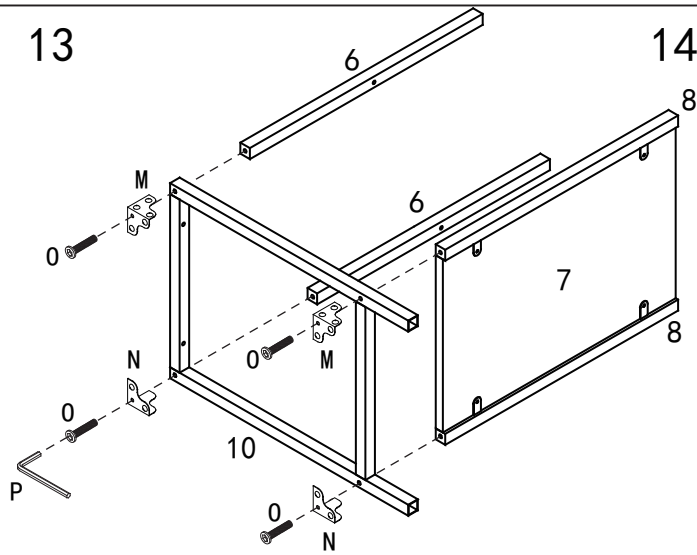

Attach metal decoration(M,N) on right leg(10) and fix (M,N) with leg and metal tubes(6,8) with bolt(O) by using hex wrench.

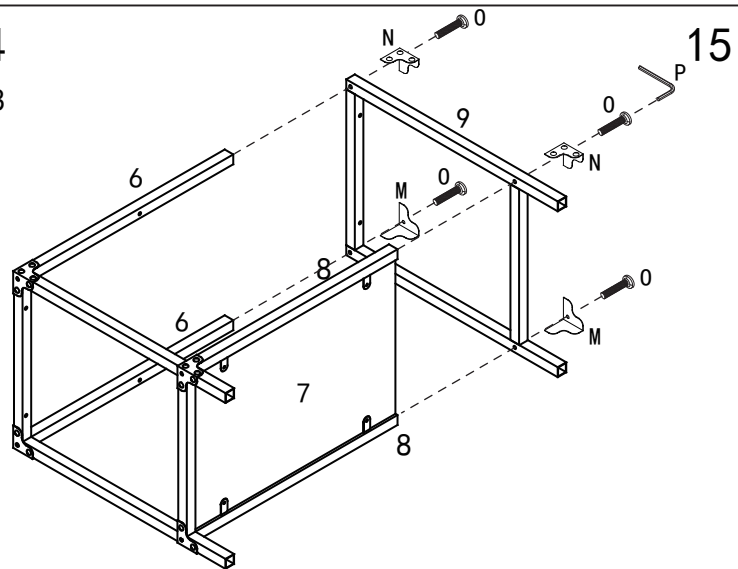

Repeat 13 step to left side.

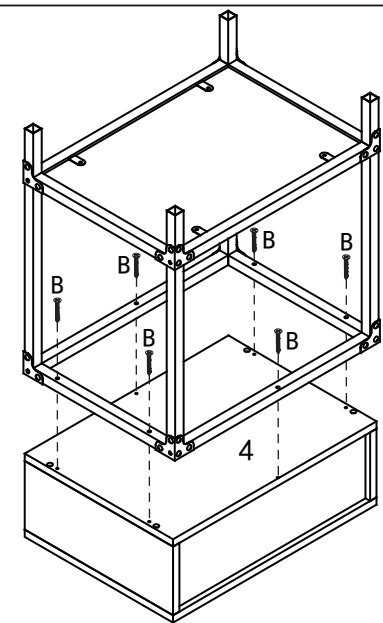

Fix assembled bottom part to top part with 6pc screw(B) as shown.

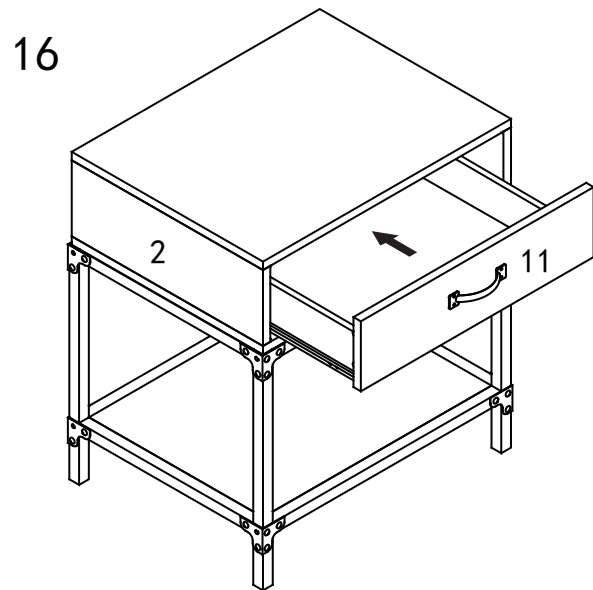

Insert the drawer to assembled part.

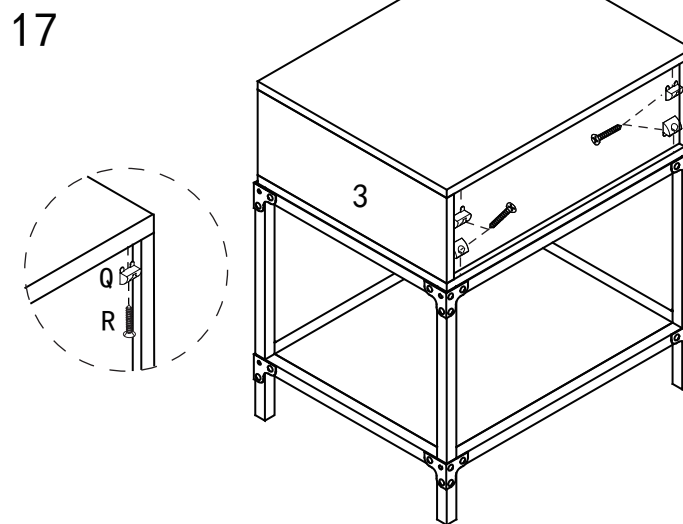

Fix the board fixer(Q) to back panel with 4pc screw(R).

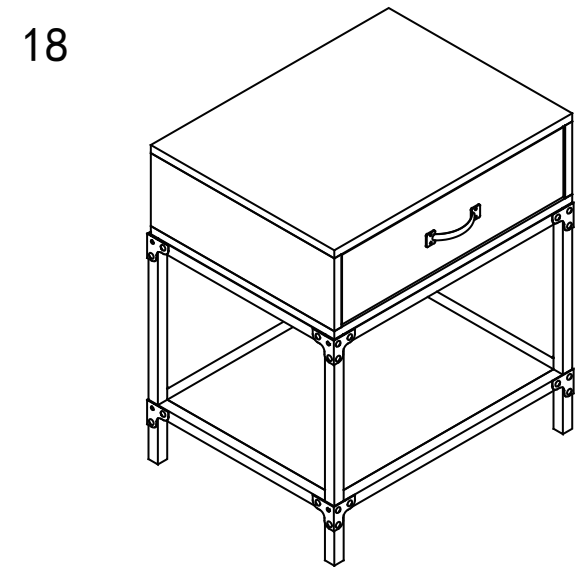

Finish assembly.