

# Assembly | Asambla | Assemblage

PO#

Customer service | Servicio al cliente | Service clientèle: 800.633.5096

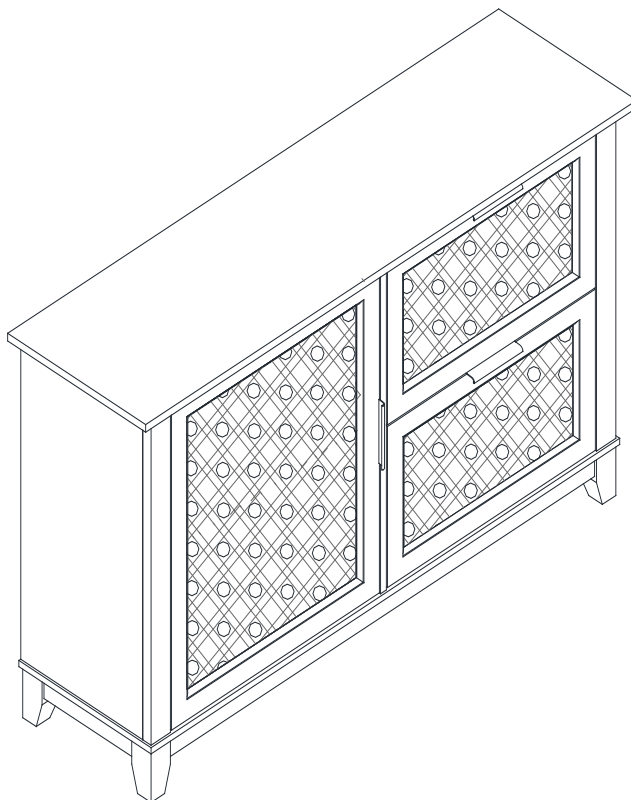

Product number | Número de producto | Numéro de produit

**HZ1003005**

Thank you for your purchase! | ¡Gracias por tu compra! | Merci pour votre achat!

# Assembly | Asambla | Assemblage

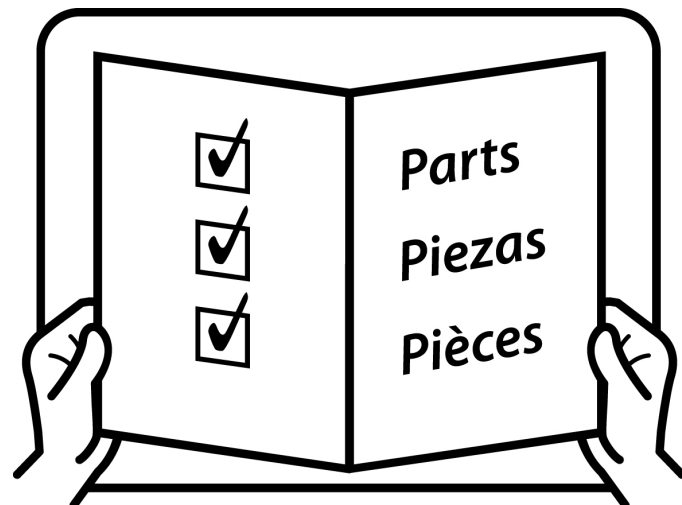
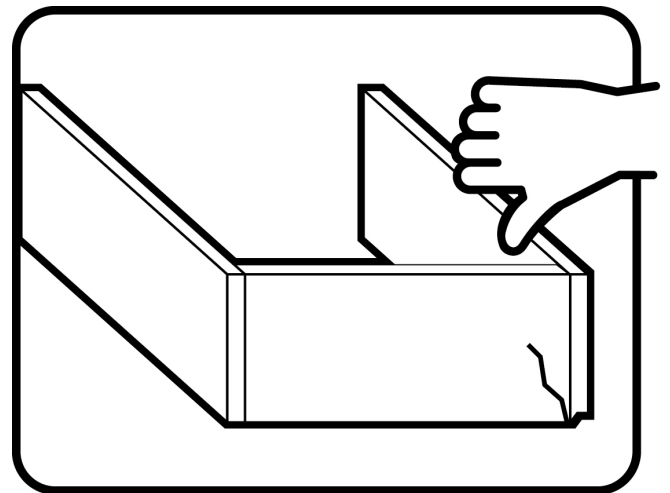
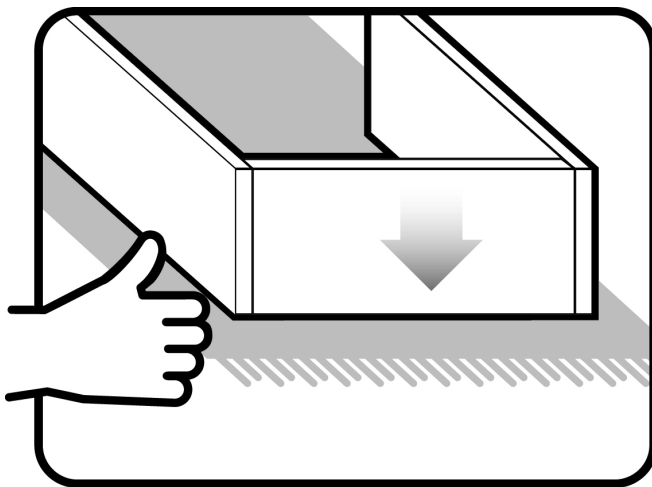
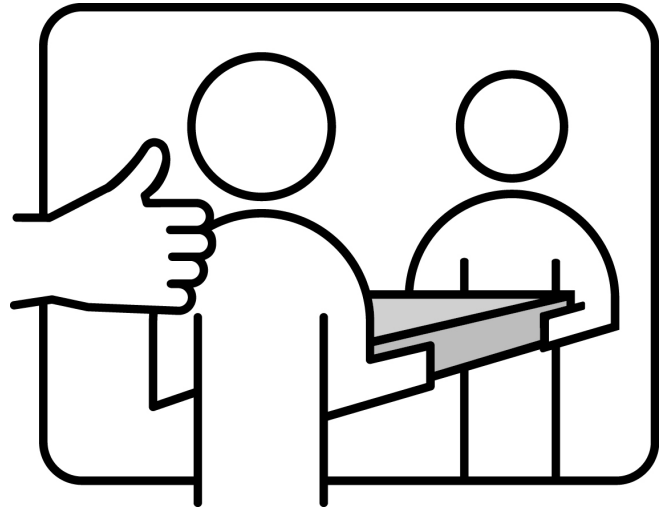
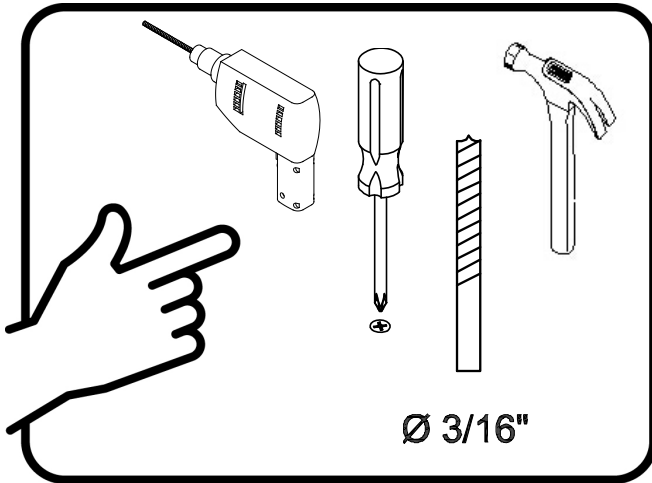

# Assembly | Asamblea | Assemblage

Techniques | Técnicas | Techniques

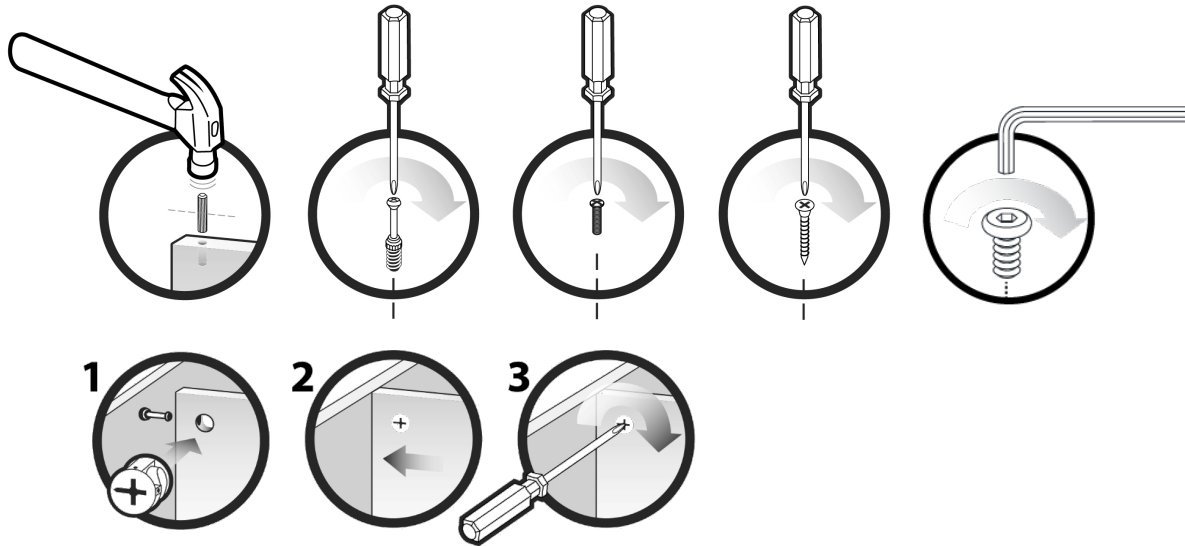

Care | Cuidado | Entretien



Safety | Seguridad | Sécurité



Note! | ¡Nota! | Remarque!



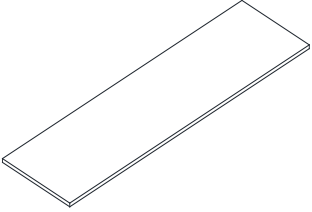
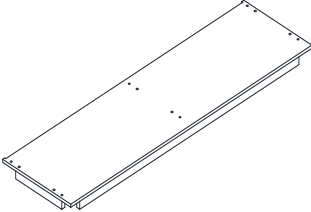
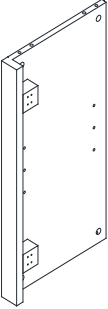
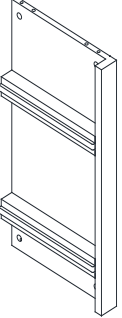
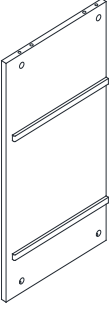
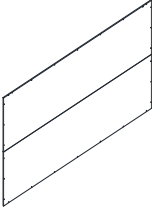
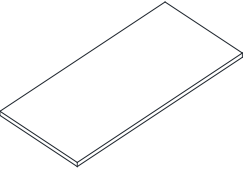
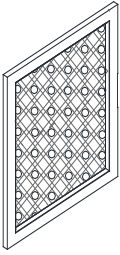
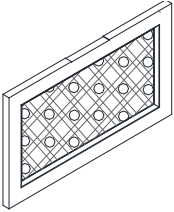
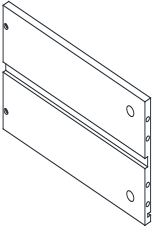
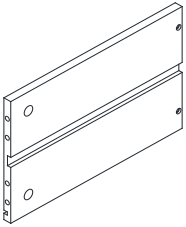
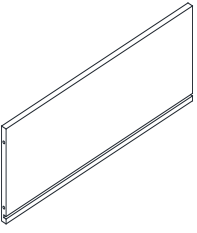

# Assembly | Asamblea | Assemblage

<p>A x1</p>  <p>Top panel Panel superior Panneau du haut</p>	<p>B x1</p>  <p>Bottom panel Panel inferior Panneau du bas</p>	<p>C x1</p>  <p>Left side panel Panel lateral izquierdo Panneau latéral gauche</p>
<p>D x1</p>  <p>Right side panel Panel lateral derecho Panneau latéral droit</p>	<p>E x1</p>  <p>Vertical panel Panel vertical Panneau vertical</p>	<p>F x1</p>  <p>Back panel Panel posterior Panneau arrière</p>
<p>G x1</p>  <p>Shelf Estante Étagère</p>	<p>H x1</p>  <p>Door Puerta Porte</p>	<p>I x2</p>  <p>Drawer front Frente de cajon Façade de tiroir</p>
<p>J x2</p>  <p>Drawer side left Cajonera izquierda Côté tiroir gauche</p>	<p>K x2</p>  <p>Drawer side right Cajonera derecho Côté tiroir droit</p>	<p>L x2</p>  <p>Drawer back Cajon atrás Tiroir arrière</p>

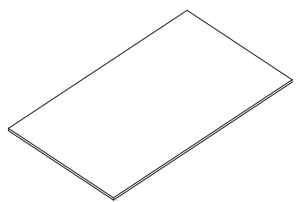
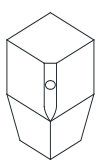
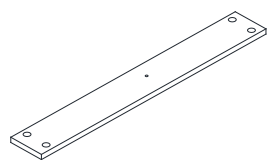

# Assembly | Asamblea | Assemblage

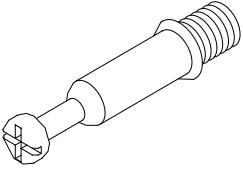
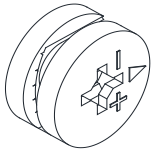
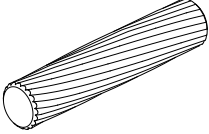
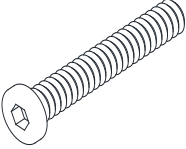
<p>M x2</p>  <p>Drawer bottom Fondo del cajon Fond du tiroir</p>	<p>N x4</p>  <p>Leg Pierna Jambe</p>	<p>O x1</p>  <p>Wood rail Carril de madera Rail en bois</p>
-----------------------------------------------------------------------------------------------------------------------------------------------------------	-------------------------------------------------------------------------------------------------------------------------------	--------------------------------------------------------------------------------------------------------------------------------------------------------

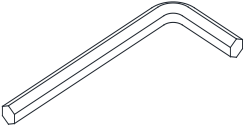
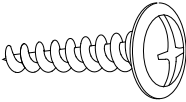
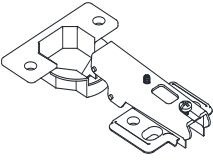
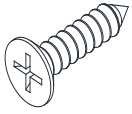
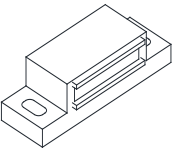
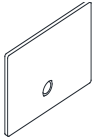
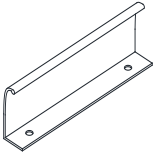
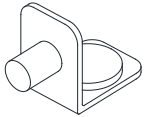
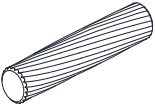
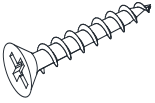
# Assembly | Asamblea | Assemblage

1	x20	2	x20	3	x12	4	x4
							
Cam bolt Tornillo de leva Boulon à came		Cam lock Bloqueo de leva Serrure à came		Wood dowel Taco de madera Cheville de bois Ø5/16"x1-1/4"L		Bolt Tornillo Boulon Ø1/4"x2"L	
5	x4	6	x4	7	x1	8	x28
							
Flat washer Arandela plana Rondelle plate		Spring washer Arandela de resorte Rondelle à ressort		Allen wrench Llave Allen Clé Allen Ø1/4"		Screw Tornillo Vis Ø1/8"x5/8"L	
9	x2	10	x22	11	x2	12	x2
							
Hinge Bisagra Charnière		Screw Tornillo Vis Ø1/8"x5/8"L		Door catch Cierre de Puerta Loquet de porte		Iron plate Placa de hierro Plat en fer	
13	x3	14	x4	15	x8	16	x8
							
Handle Mango Poignée		Shelf pin Perno de estante Potence		Wood dowel Taco de madera Cheville de bois Ø1/4"x1-1/4"L		Screw Tornillo Vis Ø8#*1"L	

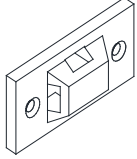
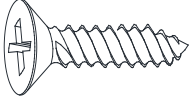
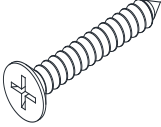
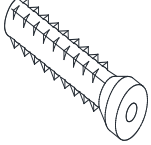
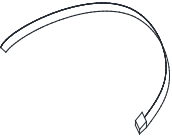
# Assembly | Asamblea | Assemblage

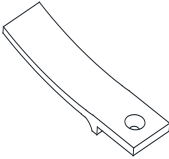
<p>17</p> <p>x4</p>  <p>Bracket Soporte Support</p>	<p>18</p> <p>x4</p>  <p>Screw Tornillo Vis ø1/8"*5/8"L</p>	<p>19</p> <p>x4</p>  <p>Screw Tornillo Vis ø1/4"*1-3/8"L</p>	<p>20</p> <p>x4</p>  <p>Anchor Ancla Ancre</p>
<p>21</p> <p>x2</p>  <p>Tie Correa Sangle</p>	<p>22</p> <p>x20</p>  <p>Cover Tapa Couverture</p>	<p>23</p> <p>x2</p>  <p>Drawer stopper Tapón de cajón Butée de tiroir</p>	

# Assembly | Asambla | Assemblage

1

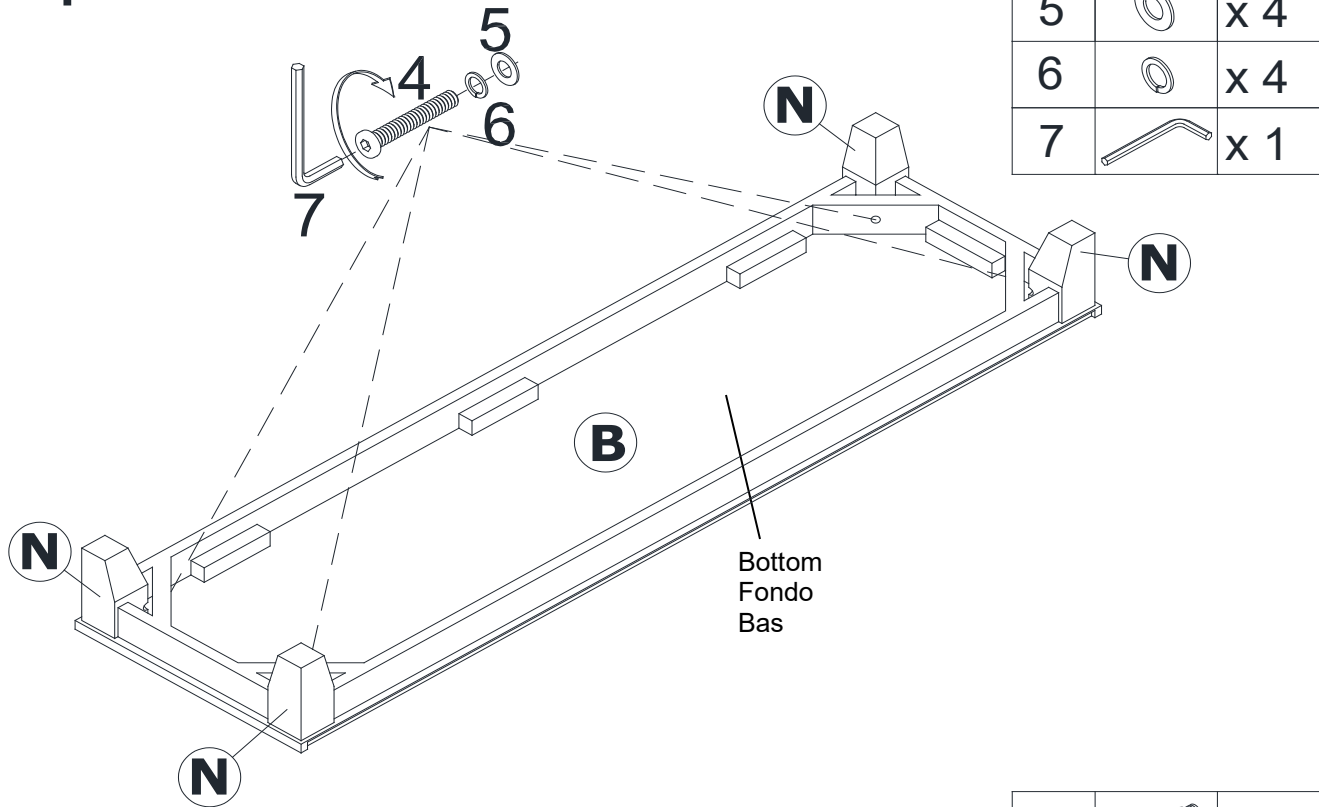

4		x 4
5		x 4
6		x 4
7		x 1

2

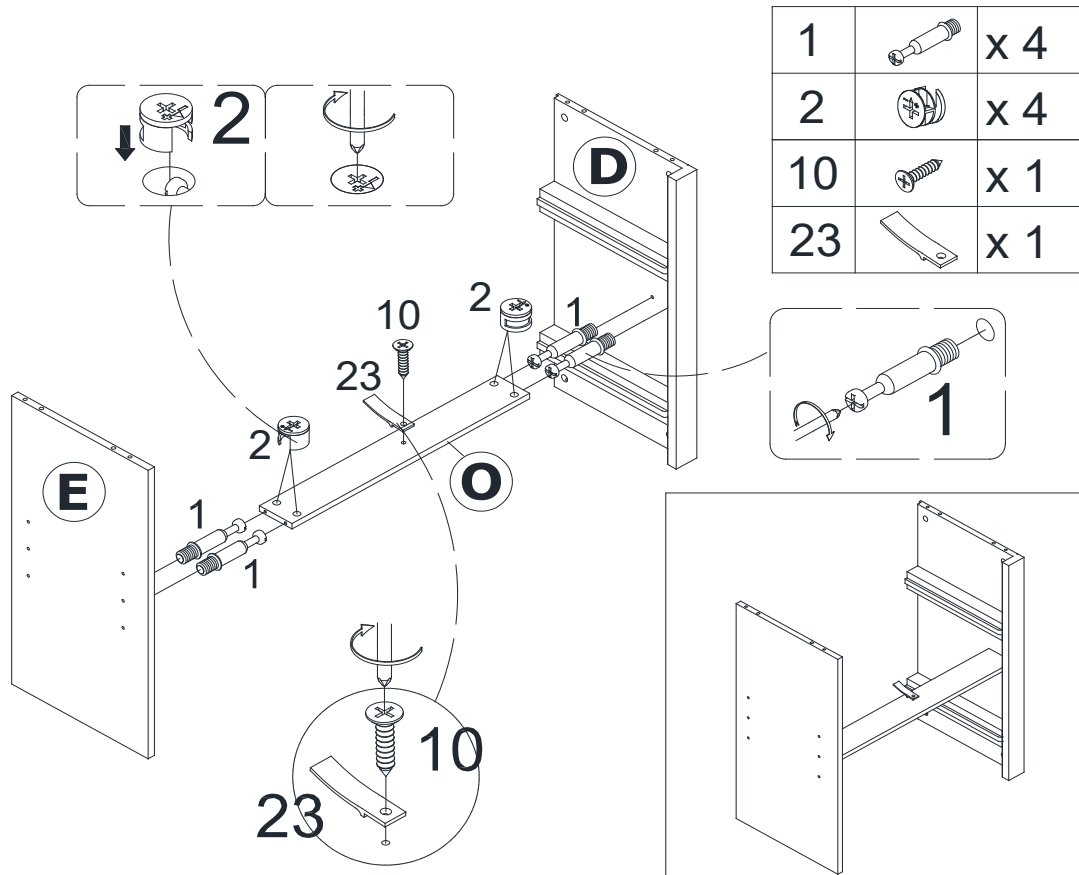

1		x 4
2		x 4
10		x 1
23		x 1



# Assembly | Asambla | Assemblage

3

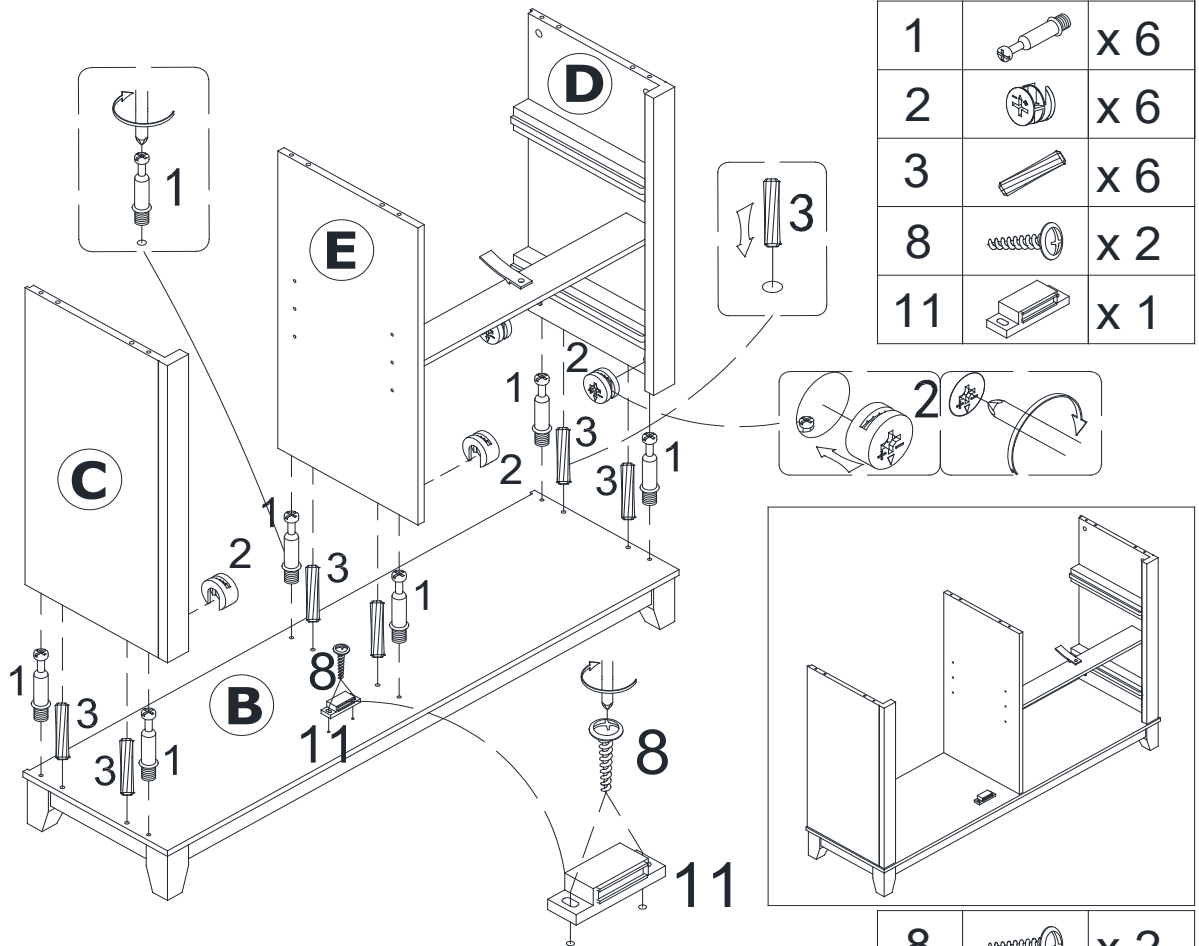

4

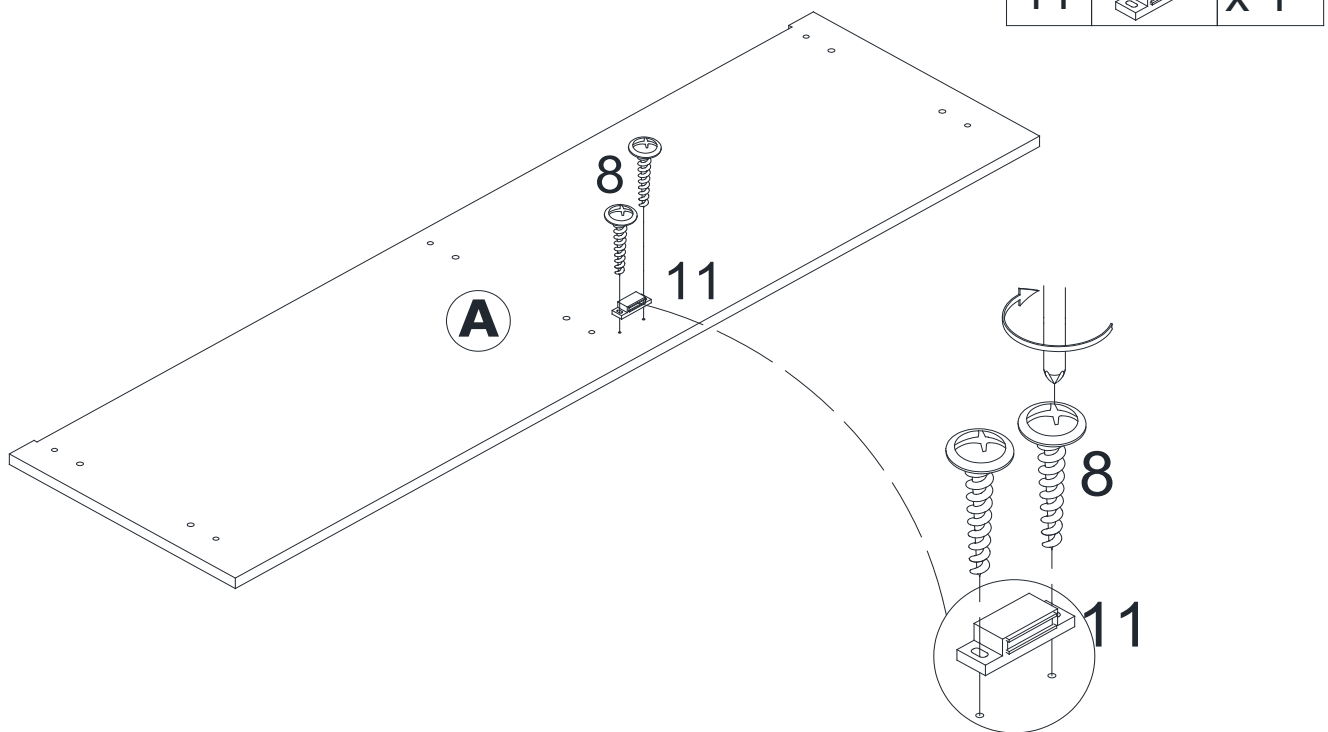

# Assembly | Asambla | Assemblage

5

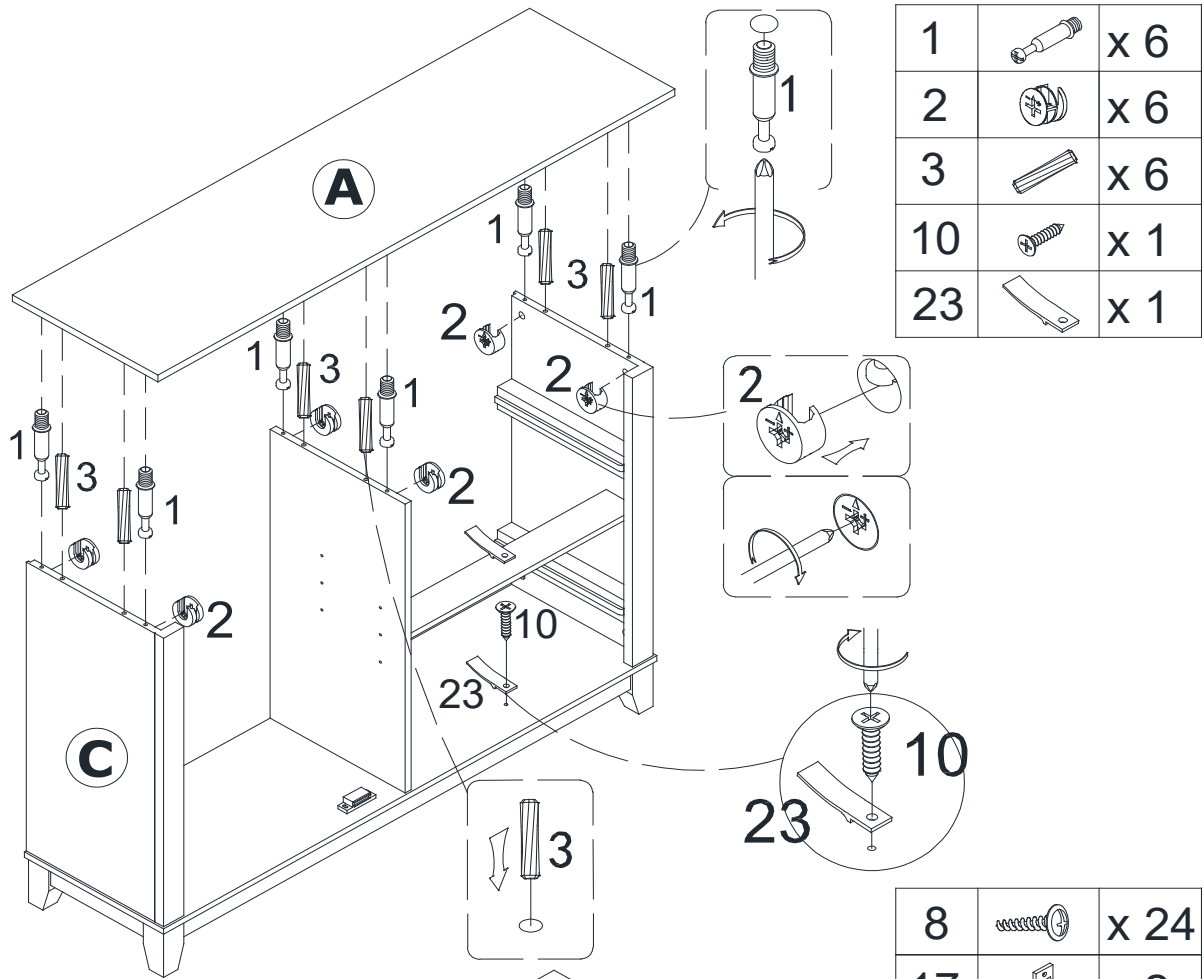

6

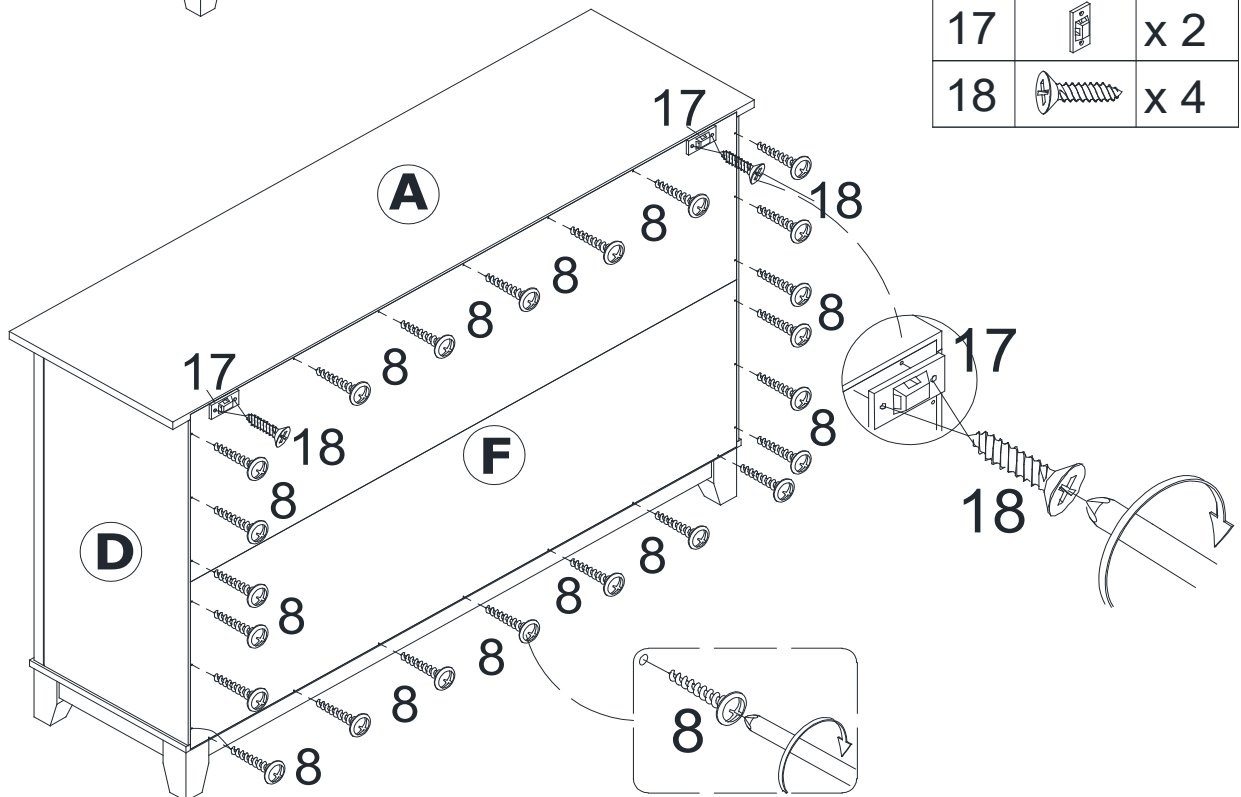



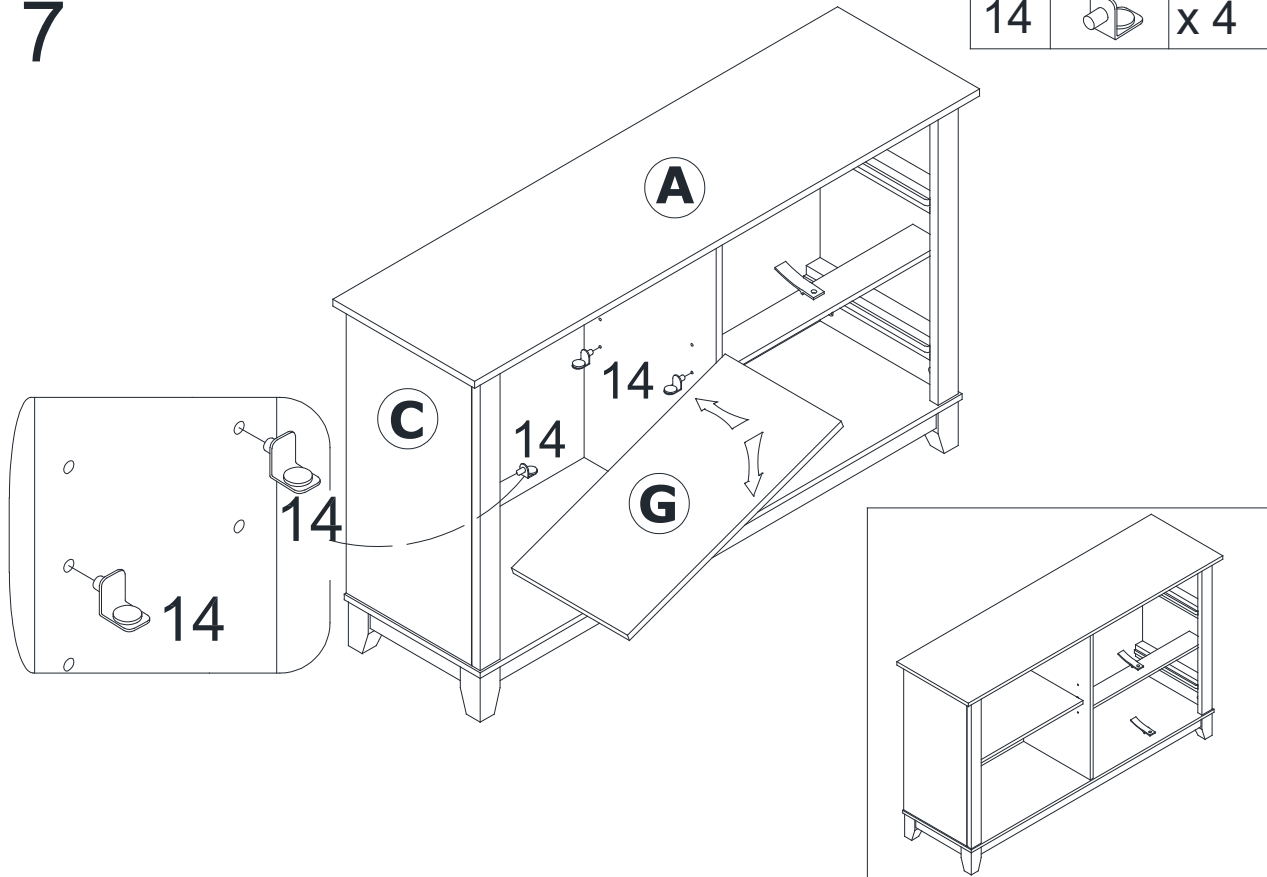

# Assembly | Asambla | Assemblage

7

14		x 4
----	-------------------------------------------------------------------------------------	-----

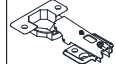

8

9		x 2
10		x 8
12		x 2
13		x 1

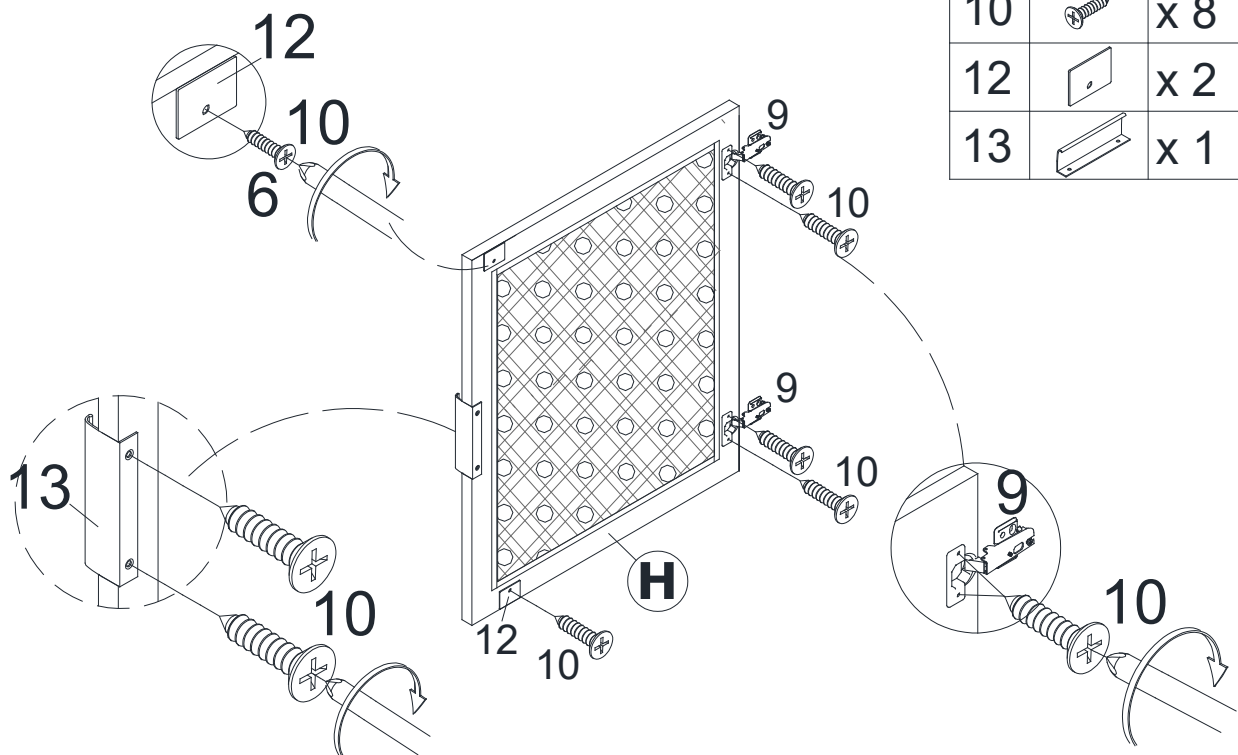

# Assembly | Asambla | Assemblage

9

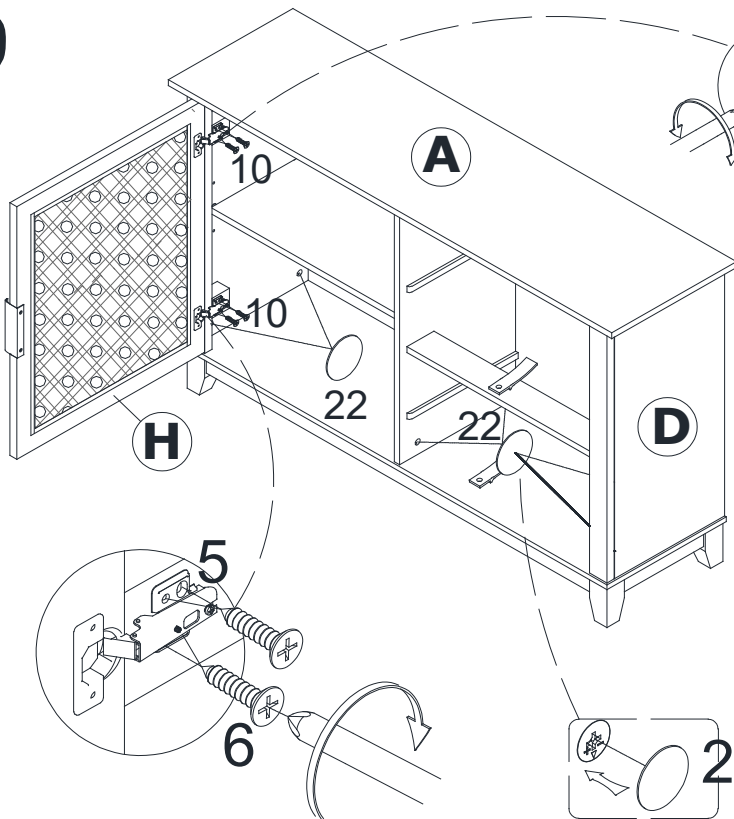

10		x 8
22		x 12

To achieve uniform clearance around the doors, tighten or loosen hinge screws as needed.

Para lograr un espacio uniforme alrededor de las puertas, apriete o afloje los tornillos de la bisagra según sea necesario.

Pour obtenir un jeu uniforme autour des portes, serrez ou desserrez les vis de charnière si nécessaire.

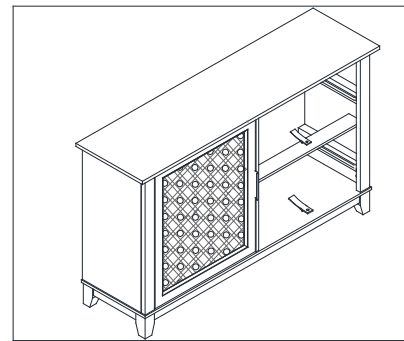

10

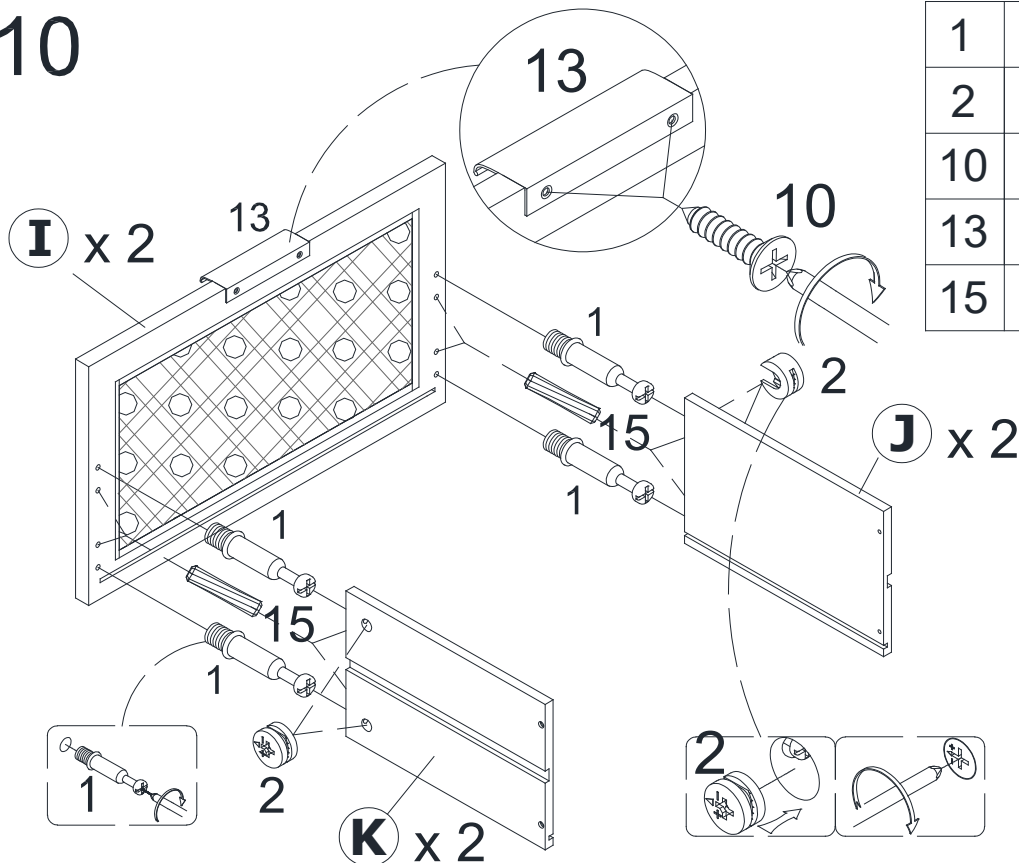

1		x 8
2		x 8
10		x 4
13		x 2
15		x 8

# Assembly | Asambla | Assemblage

11

22		x 8
----	-------------------------------------------------------------------------------------	-----

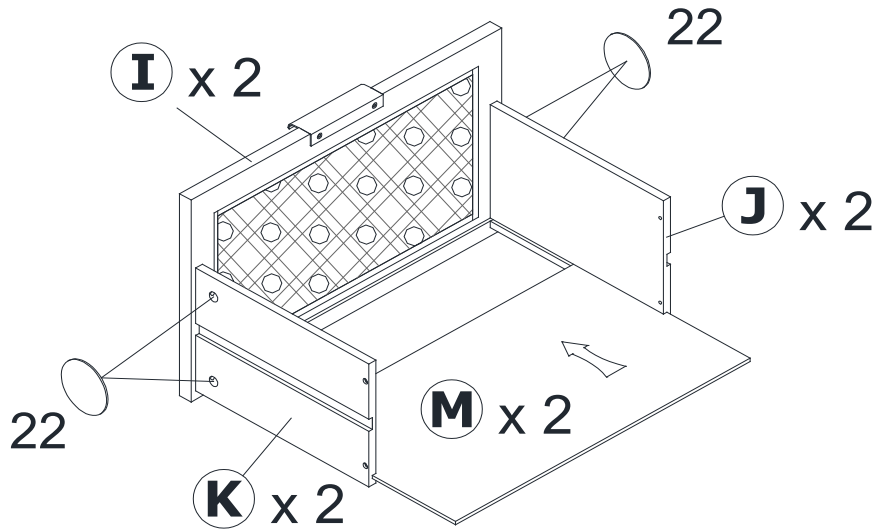

12

16		x 8
----	---------------------------------------------------------------------------------------	-----

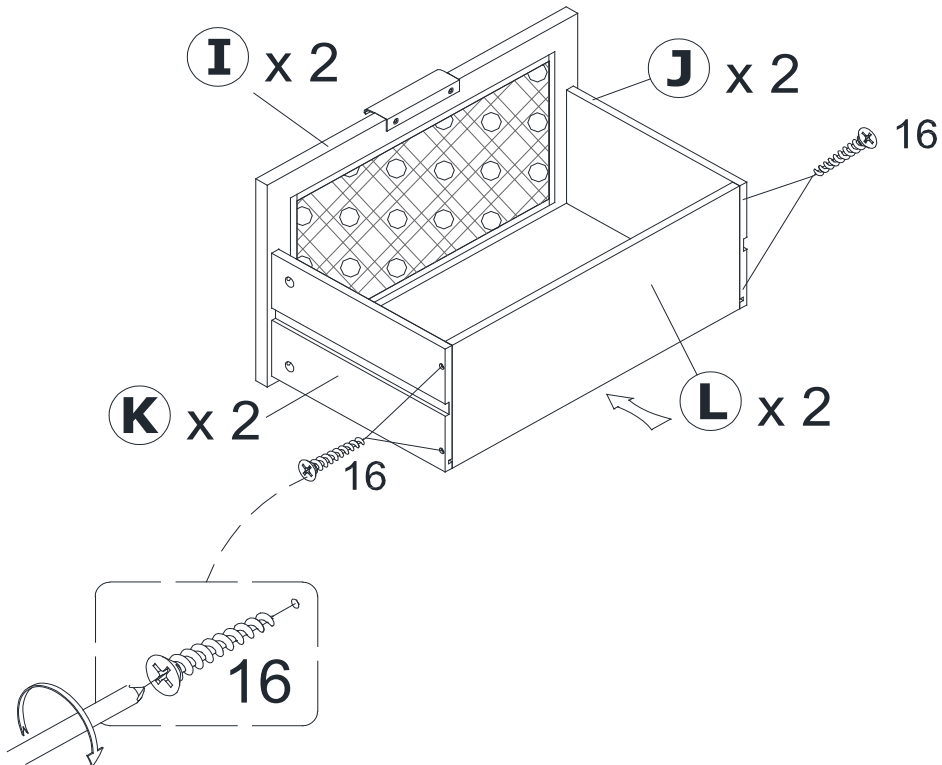

# Assembly | Asamblea | Assemblage

13

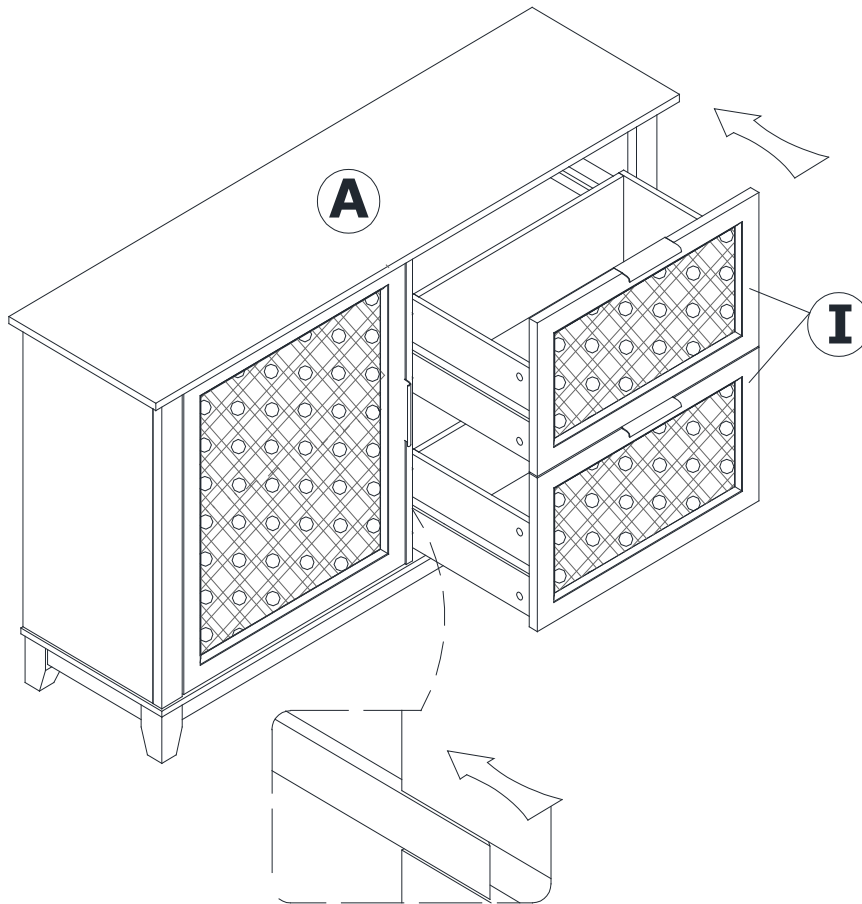

14

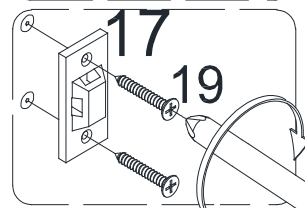
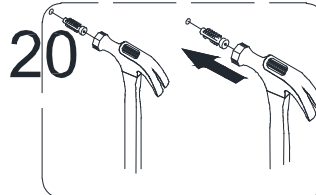
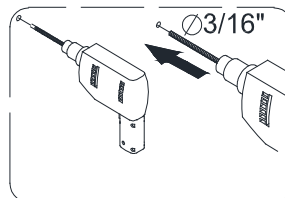
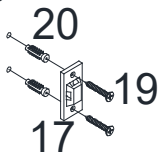
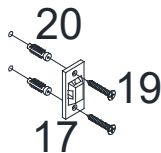
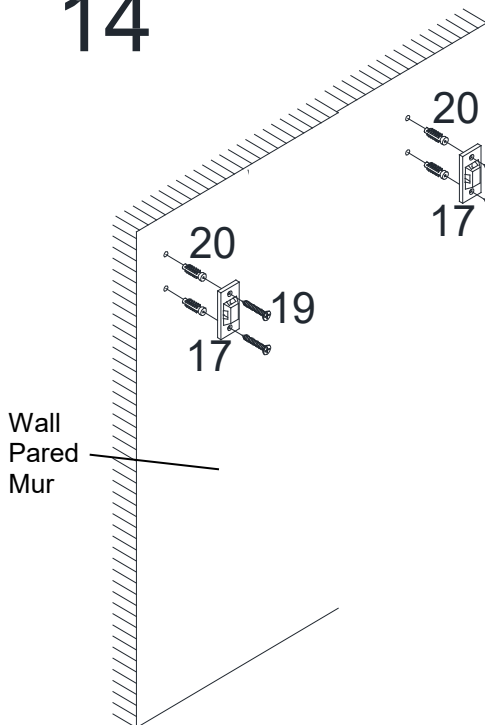

17		x 2
19		x 4
20		x 4

Anti-tipping hardware must be used for this product to avoid tipping and injury.

Se debe usar hardware antivuelco para este producto para evitar que se vuelque y se lesione.

Une quincaillerie anti-basculement doit être utilisée pour ce produit afin d'éviter tout basculement et blessure.

# Assembly | Asambllea | Assemblage

15

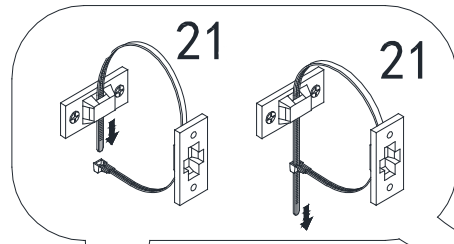

21		x 2
----	-------------------------------------------------------------------------------------	-----

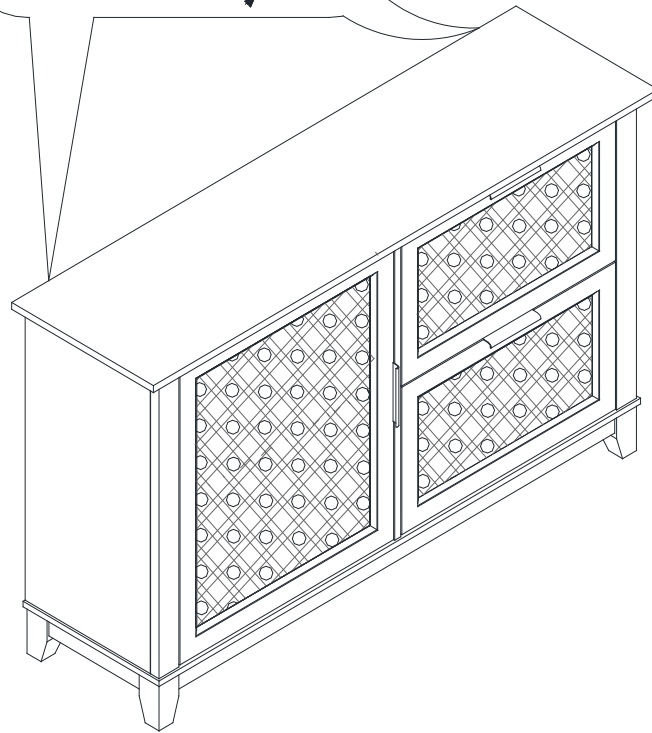

# Assembly | Asamblea | Assemblage

## May We Help You? 800.633.5096

Please have this information ready when you call:

- Item Number
- PO #
- Purchaser Name
- Place of Purchase
- Purchase Date
- Date Product Arrived

Immediately examine this product carefully. Any request for missing or damaged part replacement must be received within 90 days of your receipt of the product. Requests for replacement parts, if available, will be honored within this time frame. Parts will not be available for items arriving fully assembled. We do not recommend modifying products and we are not responsible for any damages due to product modifications. If damages or missing parts are not reported within 90 days of receiving the product, we are under no obligation to provide parts or replacement merchandise. For product issues, please contact customer service at 800-633-5096 (toll-free) Mon-Fri 8:30am – 5pm CST. Please ask for a customer service representative for issues involving damages or replacement parts. Please ask for a technical assistance representative for any issues related to product assembly/construction. Regarding product returns, please contact the retailer from whom you purchased the product.

Please note, for items purchased in a retail store, you will need to contact the retailer for all part needs.

Products purchased at garage sales or discount stores are sold as-is and are not covered by the above warranty

## ¿Podemos ayudarle? 800.633.5096

Tenga a mano esta información cuando llame:

- Número de artículo
- PO #
- Nombre del comprador
- Lugar de compra
- Fecha de compra
- Fecha en que llegó el producto

Inmediatamente examine este producto con cuidado. Cualquier solicitud de reemplazo de piezas faltantes o dañadas debe recibirse dentro de los 90 días posteriores a la recepción del producto. Las solicitudes de repuestos, si están disponibles, serán atendidas dentro de este marco de tiempo. Las piezas no estarán disponibles para los artículos que lleguen completamente ensamblados. No recomendamos modificar los productos y no nos hacemos responsables de los daños debidos a las modificaciones del producto. Si no se informan daños o piezas faltantes dentro de los 90 días de haber recibido el producto, no estamos obligados a proporcionar piezas o productos de reemplazo. Para problemas con el producto, comuníquese con el servicio al cliente al 800-633-5096 (sin cargo) de lunes a viernes, de 8:30 a. M. A 5 p.m. CST. Solicite a un representante de servicio al cliente si tiene problemas con daños o piezas de repuesto. Solicite un representante de asistencia técnica para cualquier problema relacionado con el montaje / construcción del producto. Con respecto a las devoluciones de productos, comuníquese con el vendedor al que le compró el producto.

Tenga en cuenta que, para los artículos comprados en una tienda minorista, deberá comunicarse con el minorista para todas las necesidades de piezas.

Los productos comprados en las ventas de garaje o tiendas de descuento se venden tal como están y no están cubiertos por la garantía anterior.

## Pouvons-nous vous aider? 800.633.5096

Veuillez avoir cette information à portée de main lorsque vous appelez:

- Numéro d'article
- PO #
- Nom de l'acheteur
- Lieu d'achat
- Date d'achat
- Date d'arrivée du produit

Immédiatement examiner ce produit soigneusement. Toute demande de remplacement de pièce manquante ou endommagée doit être reçue dans les 90 jours suivant la réception de votre produit. Les demandes de pièces de rechange, si elles sont disponibles, seront honorées dans ce délai. Les pièces ne seront pas disponibles pour les articles arrivant complètement assemblés. Nous ne recommandons pas de modifier les produits et nous ne sommes pas responsables des dommages causés par des modifications du produit. Si les dommages ou les pièces manquantes ne sont pas signalés dans les 90 jours suivant la réception du produit, nous ne sommes pas tenus de fournir des pièces ou des produits de remplacement. En cas de problème avec le produit, veuillez contacter le service clientèle le 800-633-5096 (sans frais) du lundi au vendredi de 8h30 à 17h, heure de Paris. S'il vous plaît demander à un représentant du service clientèle pour les problèmes impliquant des dommages ou des pièces de rechange. Veuillez demander à un représentant de l'assistance technique de résoudre tout problème lié à l'assemblage / la construction du produit. En ce qui concerne les retours de produits, veuillez contacter le détaillant chez qui vous avez acheté le produit.

Veuillez noter que pour les articles achetés dans un magasin de détail, vous devez contacter le détaillant pour tous les besoins en pièces.

Les produits achetés dans les vide-greniers ou les magasins à prix réduits sont vendus tels quels et ne sont pas couverts par la garantie ci-dessus.