

**Assembly Instructions**

**6768WC**

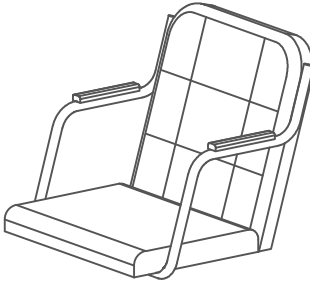

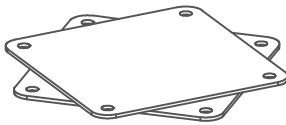
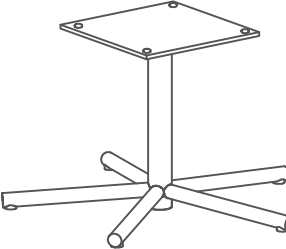
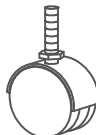

# Parts List

label	Picture	Qty
A		1
B		1
C		1
D		5

# Hardware List

label	Picture	Description	Size	Qty
H-1		Bolt	M6x25 mm	8
H-2		Gasket		8
H-3		Gasket		8
H-4		Nut		4

# Tool List

label	Picture	Description	Size	Qty
T-1		Allen Key	φ4 mm	1
T-2		Wrench		1

# Assembly Steps

ATTENTION:

DO NOT COMPLETELY TIGHTEN ANY SCREWS UNTIL ALL PARTS ARE IN PLACE

## Step 1

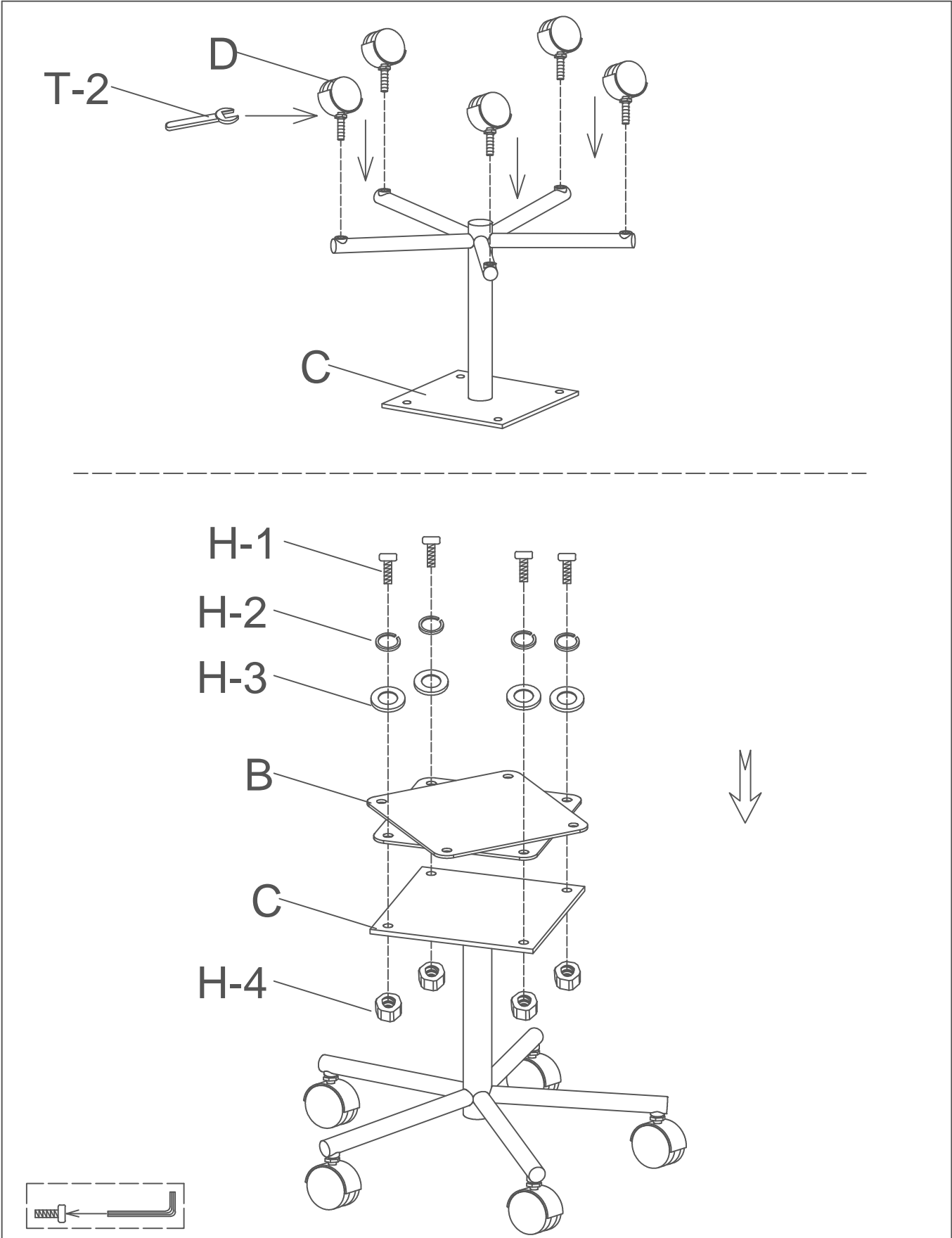

# Step 2

