

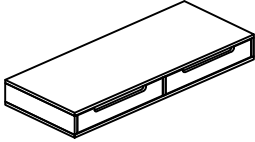







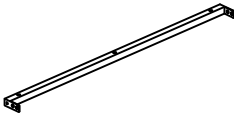
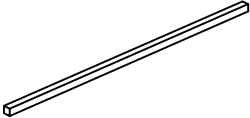

ASSEMBLY INSTRUCTION

073-15 2-DRAWER DESK

A Top  1 PC	B Left Frame  1 PC	C Right Frame  1 PC
D Top Crossbar  2 PCS	E Bottom Crossbar  1 PC	F Connecting Iron  2 PCS
G Bolt 1/4"*5/8"  12 PCS	H Bolt 1/4"*1-5/8"  2 PCS	I Bolt 1/4"*1-1/2"  8 PCS
J Flat Washer 1/4"  22PCS	K Spring Washer 1/4"  22 PCS	L Allen Key M4  1 PC

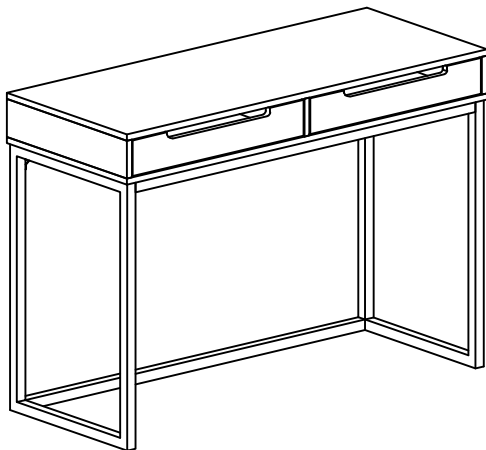

This page lists all the contents included in the box. Please take the time to identify the hardware as well as the individual components to this product. As you unpack and prepare for assembly, place the contents on a carpeted or padded area to protect them from damage.

- 1** Attach Top Crossbar (D) and Bottom Crossbar (E) to Left Frame (B) using Bolt (G), Spring Washer (K), Flat Washer (J) with Allen Key (L).

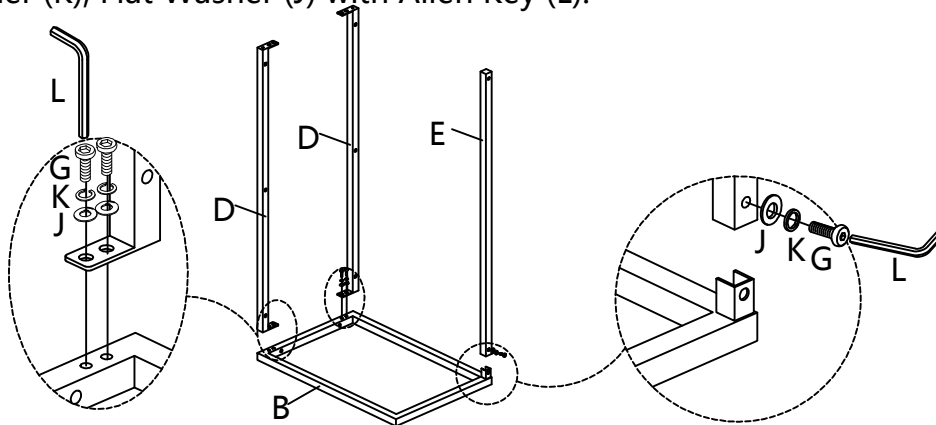

- 2** Attach Right Frame (C) to Top Crossbar (D) and Bottom Crossbar (E) using Bolt (G), Spring Washer (K), Flat Washer (J) with Allen Key (L).

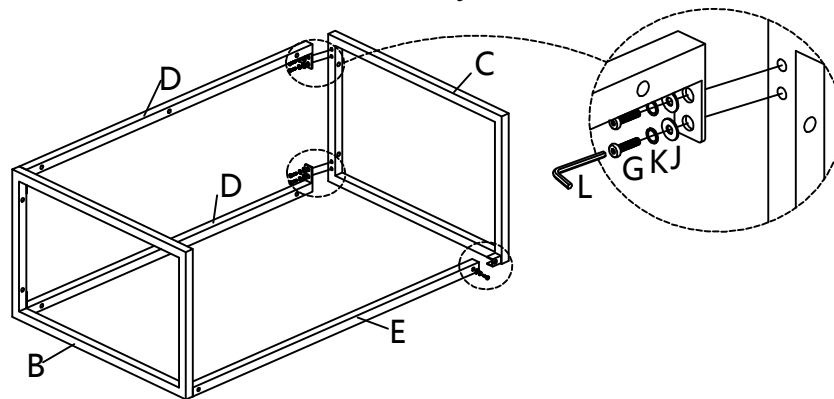

- 3** Attach Base to bottom of Top (A) using Bolt (I), Spring Washer (K), Flat Washer (J) with Allen Key (L).

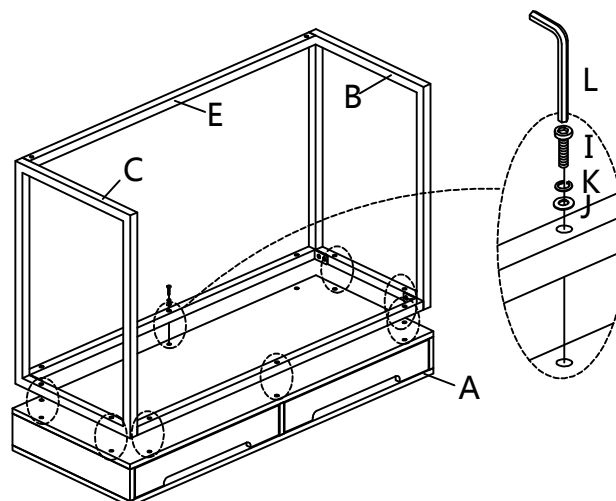

- 4** Attach Connecting Iron (F) to Left Frame (B), Right Frame (C) and Top Crossbar (D) using Bolt (H), Spring Washer (K), Flat Washer (J) with Allen Key (L).

Note : At this stage, assemble after aligning the hole position according to the position of the picture.

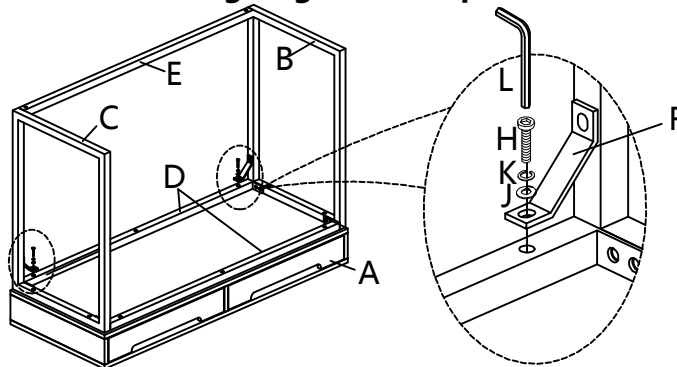

- 5** Attach Connecting Iron (F) to Left Frame (B), Right Frame (C) and Top Crossbar (D) using Bolt (G), Spring Washer (K), Flat Washer (J) with Allen Key (L).

Note : At this stage, assemble after aligning the hole position according to the position of the picture.

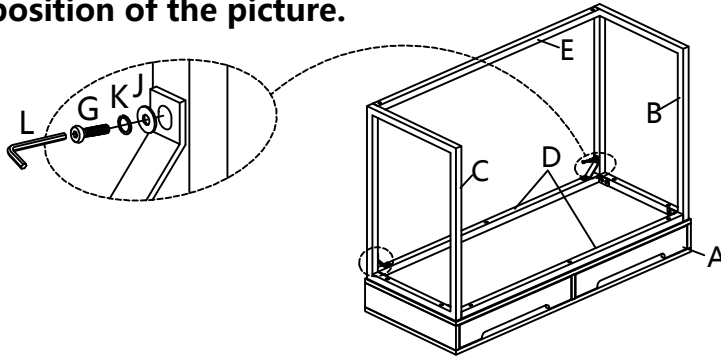

- 6** With assistance from your adult partners, turn the Desk right way up. Adjust the Pre-installed Levelers on the bottom of Left Frame (B) and Right Frame (C) until the Bookcase is level with the ground.

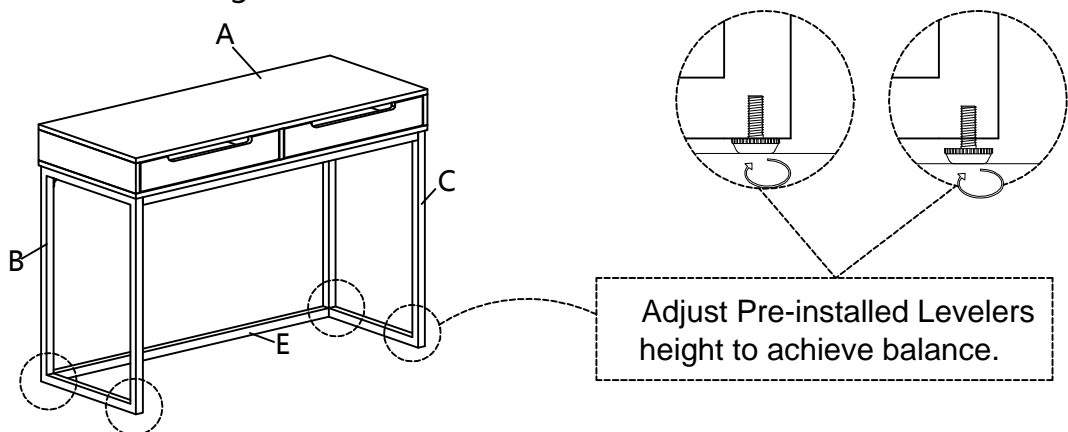

Cleaning & Care

Treat surface with care. Surface is resistant to scratches but is not scratch resistant. Clean surfaces with a dry or damp soft cloth. Do not use abrasive cleaners. Hardware may loosen over time. Periodically check that all connections are tight.