

THIS INSTRUCTION BOOKLET CONTAINS **IMPORTANT** SAFETY INFORMATION. PLEASE READ IT CAREFULLY AND KEEP FOR FUTURE REFERENCE.
ESTE MANUAL DE INSTRUCCIONES CONTIENE INFORMACION SEGURA E **IMPORTANTE** POR FAVOR LEA CUIDADOSAMENTE Y MANTENGA PARA FUTURAS REFERENCIAS.

CE LIVRET D'INSTRUCTIONS CONTIENT **D'IMPORTANTES** INFORMATIONS SUR LA SÉCURITÉ. VEUILLEZ LE LIRE ET LE CONSERVER POUR CONSULTATION ULTÉRIEURE.



DO NOT RETURN PRODUCT TO THE STORE
Individual stores do not stock parts.

NO REGRESE EL PRODUCTO A LA TIENDA
independientes no tienen las partes

NE RETOURNEZ PAS LE PRODUIT AU MAGASIN
Les détaillants ne gardent pas de pièces.

Lot number /Numero/ Numéro de lot : _____
Date of purchase /Fecha que compro/ Date d'achat : ____/____/____

If a part is missing or damaged, call our toll-free customer service line. We will gladly ship your replacement parts FREE of charge.

Si una pieza esta dañada o perdida llame a nuestro teléfono Del servicio al cliente. Con gusto le enviaremos las partes Para reemplazar las dañadas. No hay cargos adicionales es gratis.

Si une pièce est manquante ou endommagée, composez le numéro sans frais de notre service à la clientèle. Nous expédierons vos pièces de rechange GRATUITEMENT.

Need parts or assistance?
¿Necesita partes o asistencia?
Besoin de pièces ou d'assistance?

1-800-489-3351

or visit our website
O visite nuestra página de internet.
ou visitez notre site Web

www.ameriwoodhome.com

For prompt, reliable service, please have your manual ready.

Para obtener un servicio rápido por favor tenga su manual a la mano.

Pour un service rapide et fiable, ayez en main votre manuel d'assemblage.

Recommended no. of people needed for assembly : 2

Se recomienda un número de personas para ensamblar: 2

Nombre de personnes nécessaires recommandé pour l'assemblage : 2

Thank you for purchasing from Ameriwood Furniture.
Visit www.ameriwoodhome.com to view the limited warranty valid in the U.S. and Canada.

AMERIWOOD FURNITURE CUSTOMER SERVICE

Gracias por haber comprado de Ameriwood Furniture.
Visitar www.ameriwoodhome.com para mirar la garantía limitada válida solamente en U.S.A y Canada.

SERVICIO A LA CLIENTE DE AMERIWOOD FURNITURE

Before starting - Antes de empezar.

- Read each step carefully before starting. It is very important that each step of instruction is performed in the correct order. If these steps are not followed in sequence, assembly difficulties will occur.
Leer con cuidado cada paso antes de empezar. Es muy importante de ejecutar cada paso en el orden correcto. Si los pasos no están ejecutados en secuencia, ocurrirá dificultades en el montaje.
- Make sure all parts are included. Most board parts are labeled or stamped on the raw edge. Asegurar que todas las piezas son incluidas. La mayoría de las tablas tienen las etiquetas o los sellos en el lado sin acabado.
- Work in spacious area, preferably on a carpet, near the place the unit will be used. Trabajar en una área espaciosa, preferible sobre alfombra, cercas del lugar donde se va a usar el mueble.
- Have the following tools close at hand. Tener las herramientas siguientes cerca de la mano.
- Do not use power tools to assemble your furniture. Power tools may strip or damage the parts. No use herramienta eléctrica para montar su unidad. Las herramientas eléctricas pueden dañar las piezas.

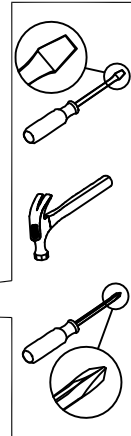

Call us at: 1-800-489-3351
Llamar a: (in U.S.A. only) (Solo en U.S.A)

Monday - Friday
9:00 am - 5:00 pm
Central Time

Lunes - Viernes
9:00h - 17:00h
Tiempo Central



Fax: 1-636-745-1005
Fax:



Visit our Website:
Visitar nuestro website: www.ameriwoodhome.com



Write to: AMERIWOOD FURNITURE
Escribir a: 410 East 1st Street South Wright City, MO 63390 USA
Attn: Service Dept.

HELPFUL HINTS

- Visit our website for assembly video clips.
- Identify, sort and count the parts before attempting assembly.
- Call our toll free number if you need assistance identifying parts.
- Compression dowels are tapped in with a hammer.
- Slides have lips only on the right side.
- Cam locks that are properly fastened on a horizontal board will face toward the center of the unit, on a vertical board the point on the lock will face the bottom.
- Back panels provide stability and support. Use all the nails provided.
- When tapping nails into a board, be sure there are equal margins on all sides to square the unit.
- Units without the back panel installed may collapse.
- Clean the product with your favorite furniture polish and a soft cloth. DO NOT USE harsh chemicals or abrasive cleaners.
- Move your new furniture carefully, with two people lift and carry the unit to its new location.
- Never push, drag or scoot your furniture (especially on carpet).
- Your furniture can be disassembled and reassembled to move.
- Additional parts are available for a nominal fee.

NOTES UTILES

- Visitar nuestro website para mirar los videos cortos del montaje.
- Identificar, clasificar y contar las piezas antes de intentar el montaje.
- Llamar gratis a nuestro número de servicio si necesita ayuda con identificar las piezas.
- Las clavijas de compresión se taladran con un martillo.
- Las correderas sólo tienen las proyecciones en el lado derecho.
- Las cerraduras de leva que se atan propiamente en una tabla horizontal se puntan al centro de la unidad, y las en una tabla vertical se puntan al fondo.
- Los paneles traseros se mantienen la estabilidad. Usar todos los tornillos proporcionados.
- A taladrar los tornillos en una tabla, asegurarse que hay márgenes iguales en todos los lados para cuadrar la unidad.
- Las unidades sin panel trasero pueden derrumbarse.
- Limpiar la unidad con su pulimento favorito de mueble y una tela suave. NO UTILIZAR productos con químicos duros o abrasivos.
- Mover su mueble nuevo cuidadosamente, con dos personas levantar la unidad a su nuevo lugar.
- Nunca empujar o arrastrar su mueble (especialmente en alfombra).
- Poderse desmontar y volver a montar su mueble de para mover.
- Piezas adicionales están disponibles para una cuota nominal.

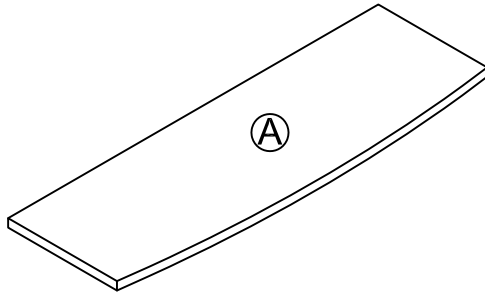

TOP
Panel superior
DESSUS
T1807096010CS

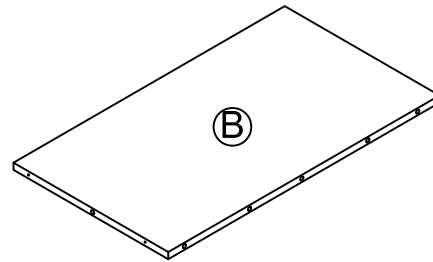

LEFT SIDE PANEL
Panel lateral izquierdo
PANNEAU GAUCHE
T1807096020CS

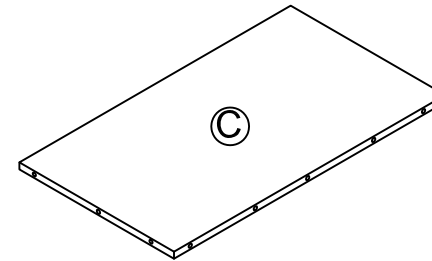

RIGHT SIDE PANEL
Panel lateral derecho
PANNEAU DROIT
T1807096030CS

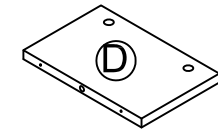

UPPER PARTITION
Partición superior
CLOISON SUPÉRIEUR
T1807096040CS

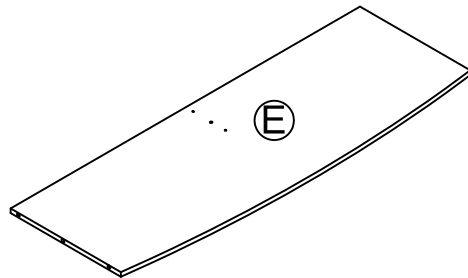

FIXED SHELF
Repisa fija
ÉTAGÈRE FIXE
T1807096050CS

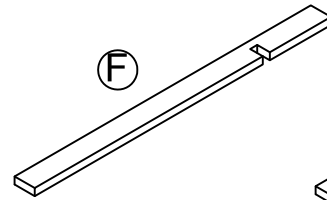

LEFT SIDE RAIL
Marco lateral izquierdo
RAIL LATÉRAL GAUCHE
T1807096060CS

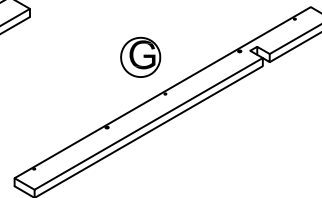

RIGHT SIDE RAIL
Carril lateral derecho
RAIL DE DROITE
T1807096070CS

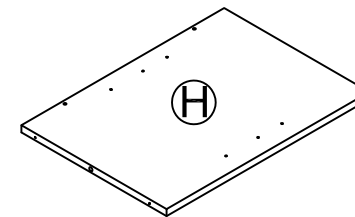

LEFT PARTITION
Partición izquierdo
CLOISON GAUCHE
T1807096080CS

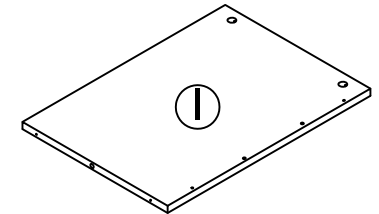

RIGHT PARTITION
Partición derecho
CLOISON DROITE
T1807096090CS

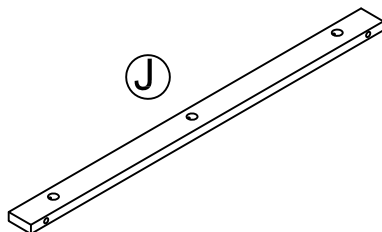

TOP APRON
Delantal superior
DESSUS TABLIER
T1807096100CS

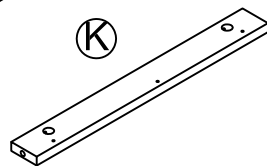

LEFT APRON
Delantal de izquierda
TABLIER GAUCHE
T1807096110CS

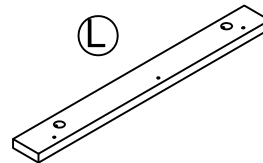

RIGHT APRON
Delantal de derecho
TABLIER DROIT
T1807096120CS

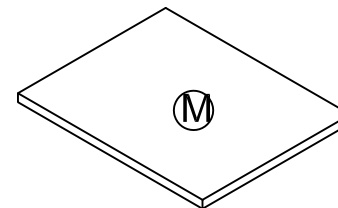

ADJUSTABLE SHELF
Repisa ajustable
TABLETTE RÉGLABLE
T1807096130CS
QTY: 2 PCS

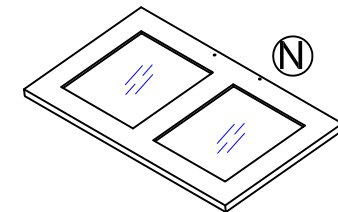

DOOR
Puerta
PORTE
T1807096140CS
QTY: 2 PCS

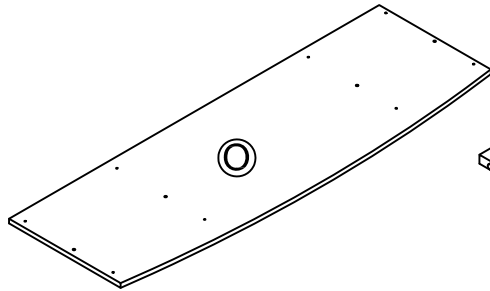

BOTTOM PANEL
Panel base
PANNEAU INFÉRIEUR
T1807096150CS

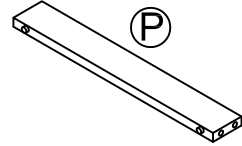

LEFT RAIL
Carril izquierdo
RAIL GAUCHE
T1807096160CS

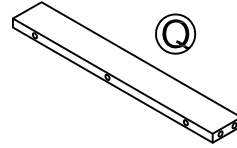

RIGHT RAIL
Carril derecho
RAIL DROIT
T1807096170CS

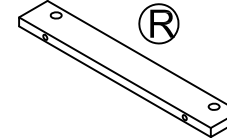

BOTTOM SUPPORT
Soporte inferior
SUPPORT INFÉRIEUR
T1807096180CS

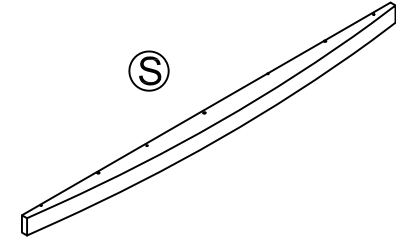

FRONT RAIL
Riel frontal
RAIL AVANT
T1807096190CS

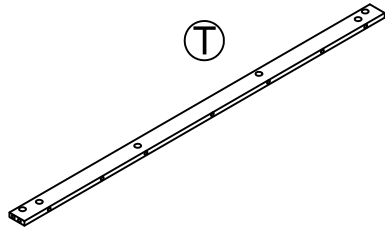

BACK RAIL
Riel trasero
RAIL ARRIÈRE
T1807096200CS



WOOD BLOCK
Bloque de madera
BLOC DE BOIS
T1807096210CS
QTY: 4 PCS

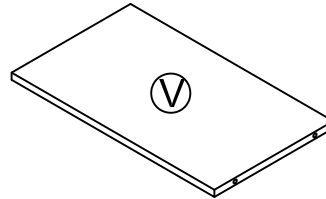

LOWER BACK PANEL
Panel trasero inferior
PANNEAU ARRIÈRE INFÉRIEUR
T1807096220CS
QTY: 2 PCS

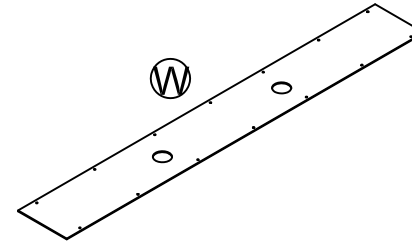

UPPER BACK PANEL
Panel trasero superior
PANNEAU ARRIÈRE SUPÉRIEUR
T1807096230CS

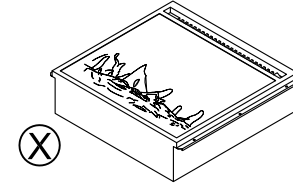

FIREPLACE
Chimenea
CHEMINÉE
FA23V60L-1

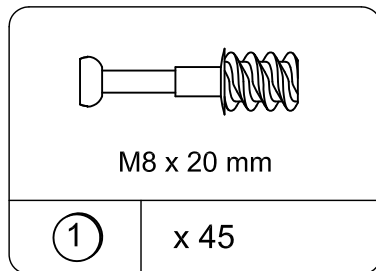

CAM BOLT
Tornillo de rosca
BOULON DE CAME
TCS2010

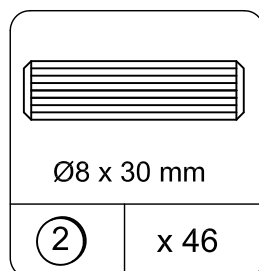

WOOD DOWEL
Clavija de madera
GOUJON EN BOIS
TCS3002

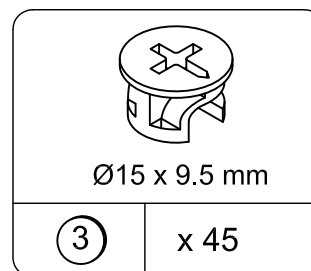

CAM LOCK
Tornillo de cerradura
SERRURE DE CAME
TCS2013

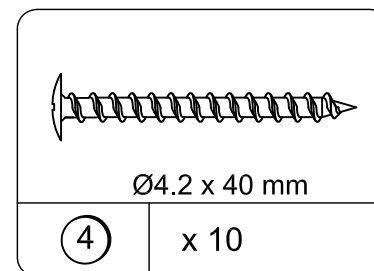

SCREW
Tornillo
VIS
TCS1059

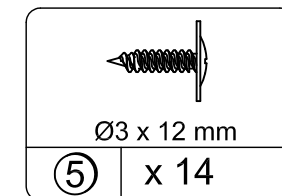

SCREW
Tornillo
VIS
TCS1048

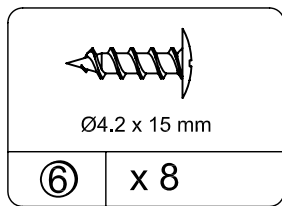

SCREW
Tornillo
VIS
TCS1065

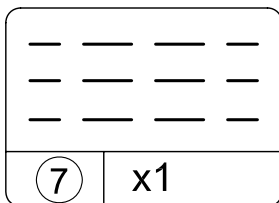

WARNING LABEL
ETIQUETA DE ADVERTENCIA
AVERTISSEMENT ÉTIQUETTE
TCS3306

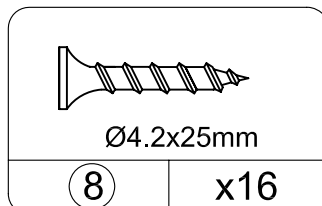

SCREW
Tornillo
VIS
TCS1069

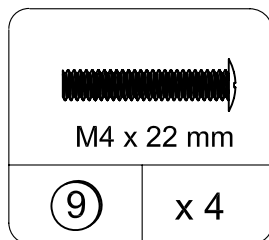

BOLT
Perno
BOULON
TCS1070

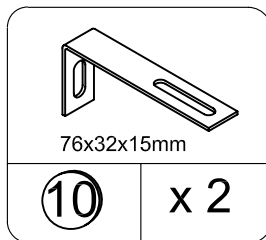

Wall bracket
Soporte para la pared
SUPPORT MURAL
TCS4004

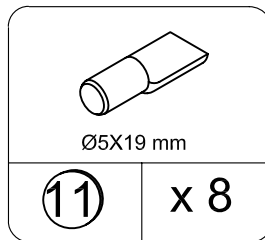

SHELF SUPPORT
Soporte de repisa
SUPPORT DE TABLETTE
TCS2009

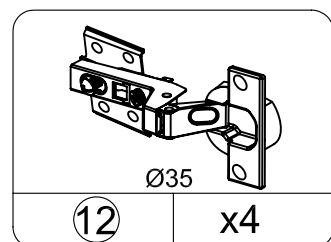

EUROPE HINGE
Europa bisagra
CHARNIÈRE EUROPE
TCS5002

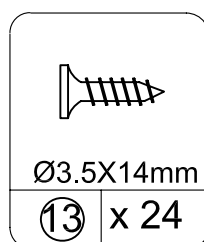

SCREW
Tornillo
VIS
TCS1055

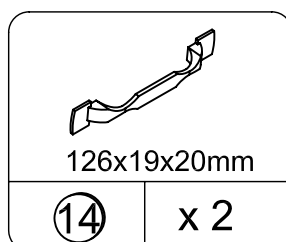

HANDLE
Manija
POIGNÉE
TCS6605

This illustration shows how the CAM fastening system works.

La ilustración muestra la fijación apropiada del seguro de la cerradura.

Cette illustration montre comment fonctionne le système de fixation de la CAME.

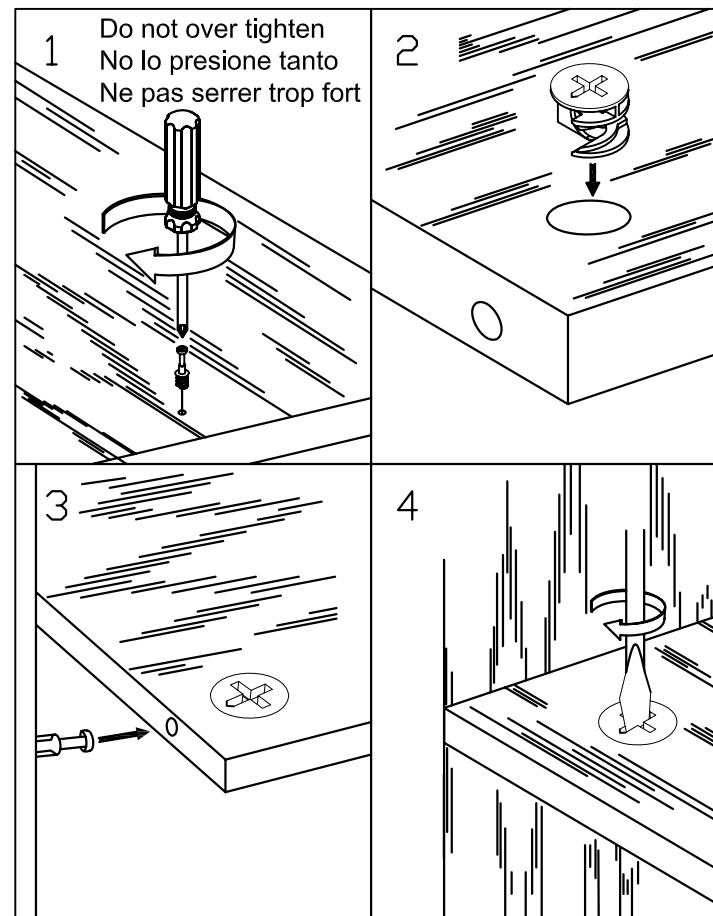

To view a video on how the CAM fastening system works, download a free QR-reader on your smartphone, then scan the code.

Mirar el vídeo sobre cómo funciona el sistema de seguro de la leva, bajar gratis el QR del documento por el teléfono y, a continuación, escanear el código.

Pour voir une vidéo sur le fonctionnement du système de fixation de la CAME, téléchargez l'application gratuite QR-reader sur votre téléphone intelligent et numérissez le code.

1

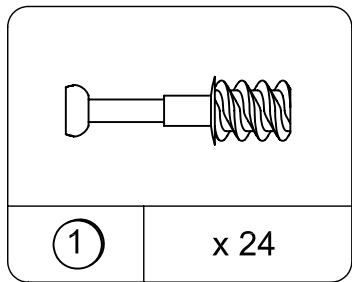
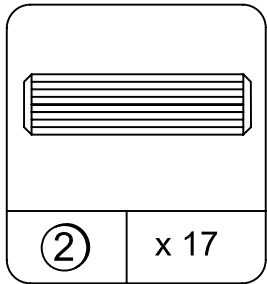
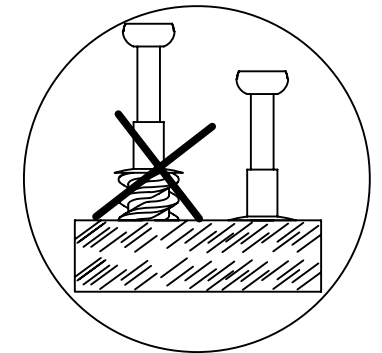
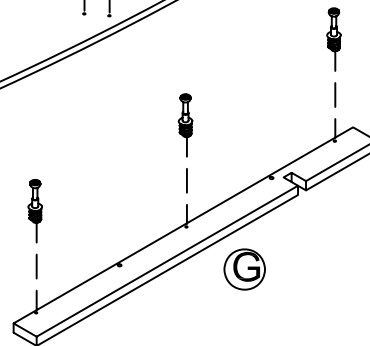
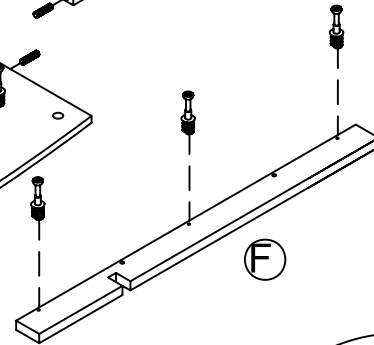
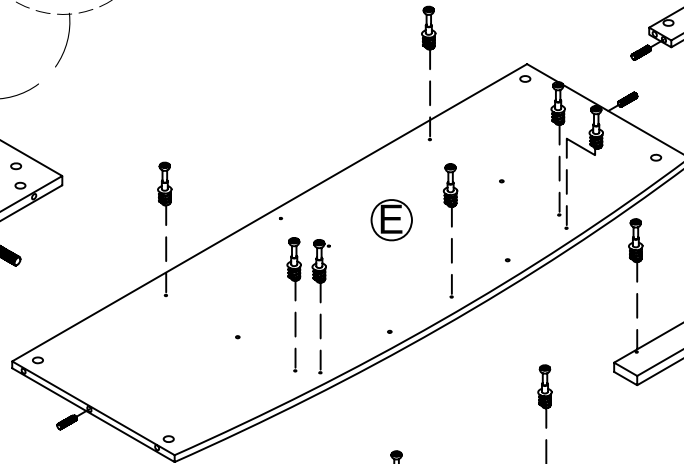
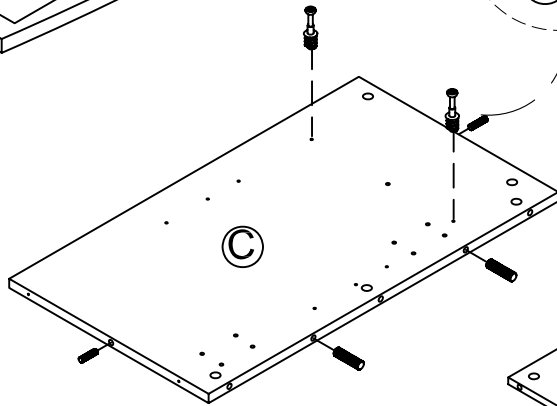
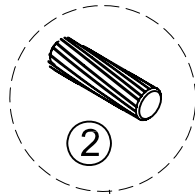
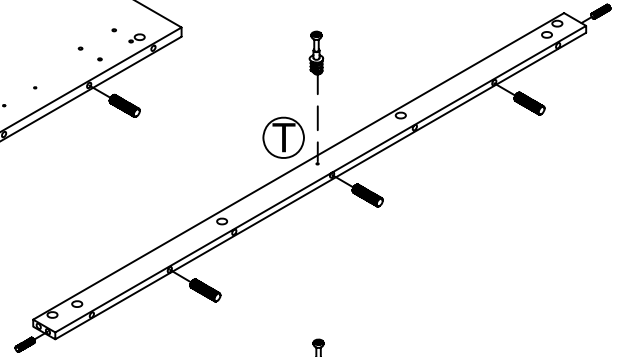
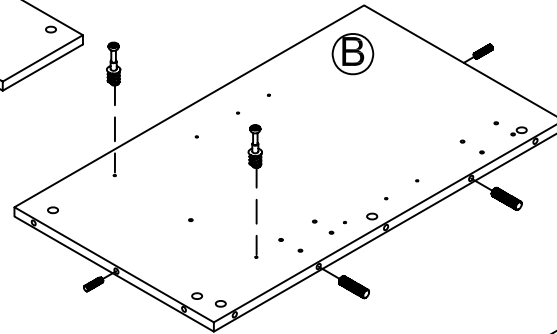
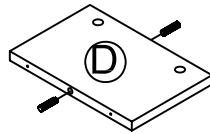
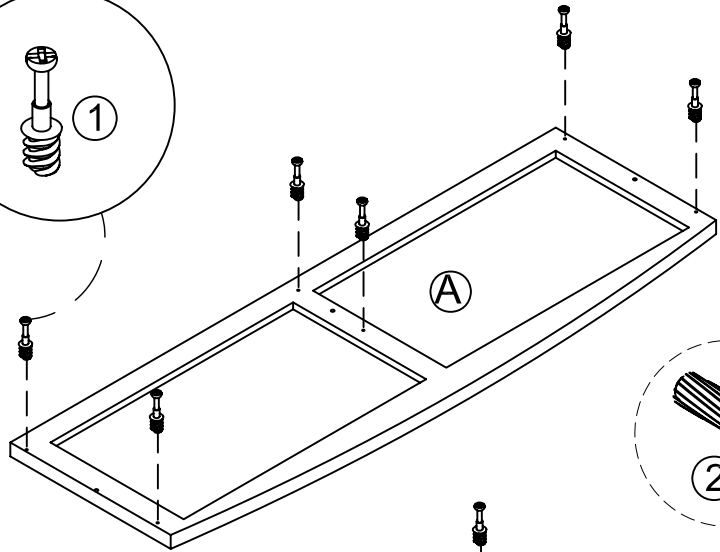
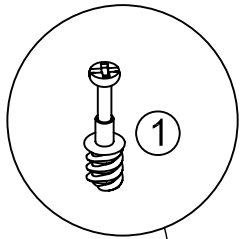

2

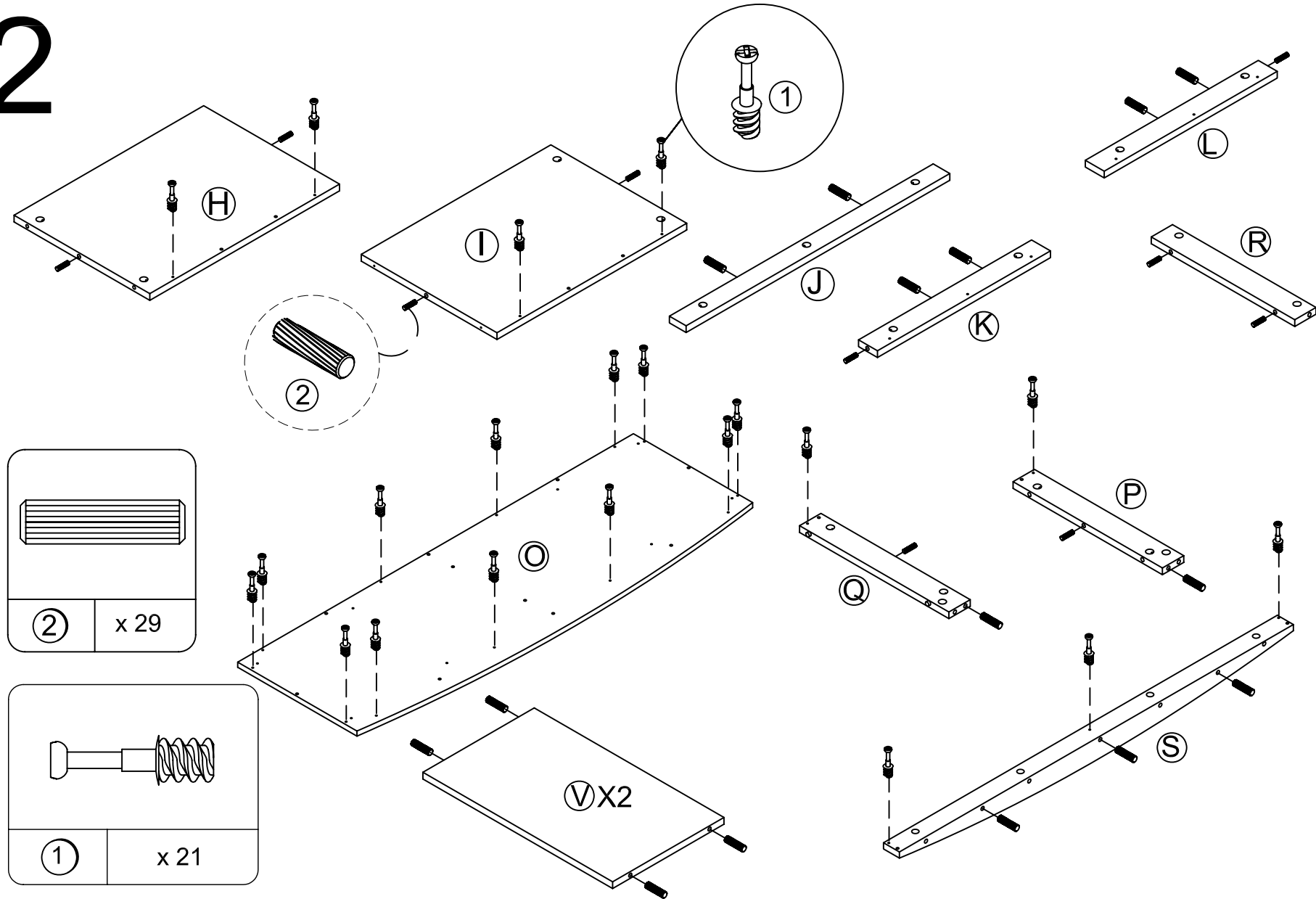

3

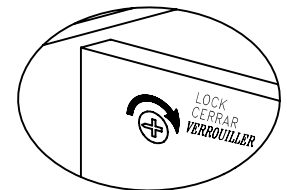
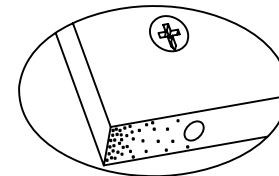
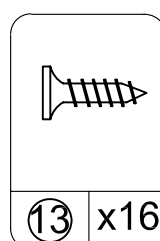
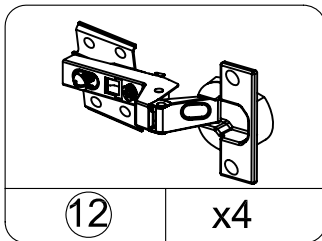
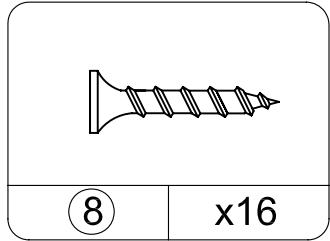
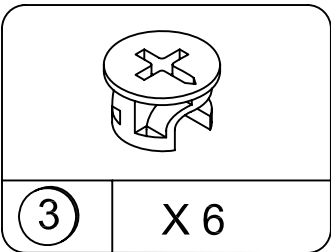
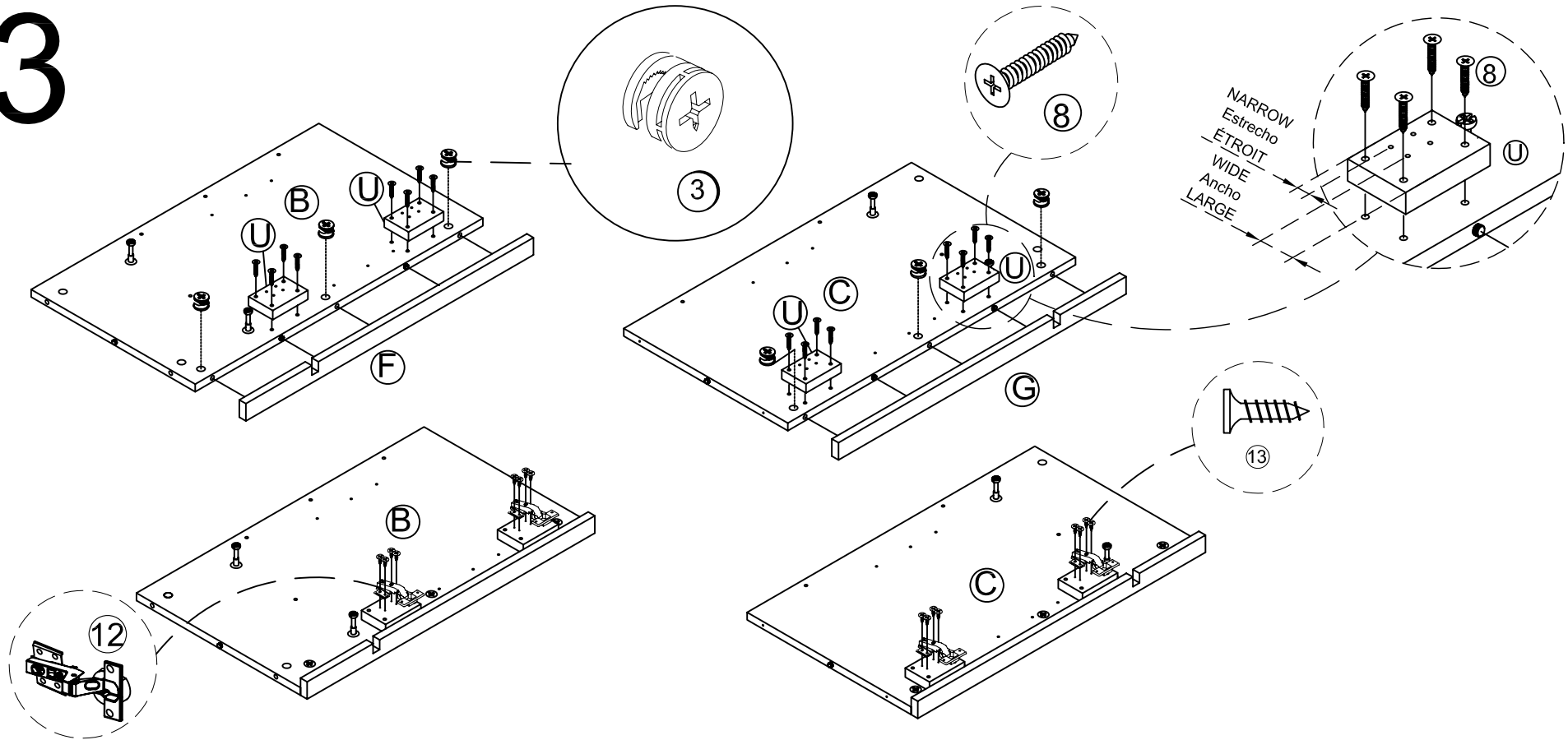

Proper orientation of CAM LOCK
 ORIENTACION APROPIADA DEL SEGURO DE LA CERRADURA
 Bonne orientation de la serrure de came.

4

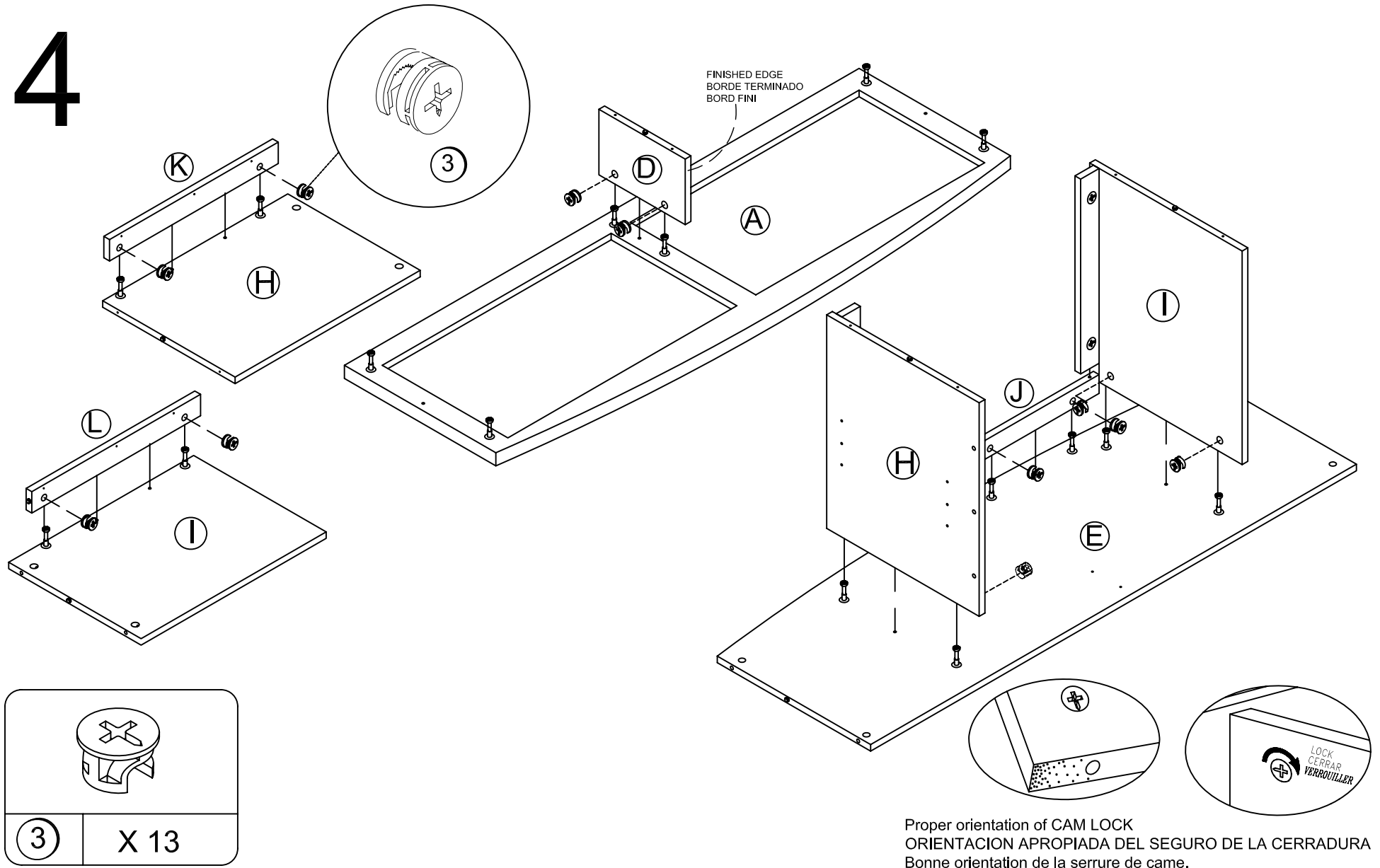

Proper orientation of CAM LOCK
ORIENTACION APROPIADA DEL SEGURO DE LA CERRADURA
Bonne orientation de la serrure de came.

5

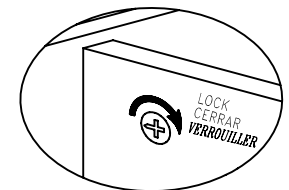
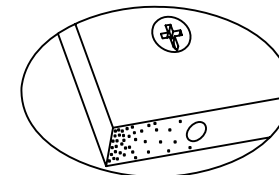
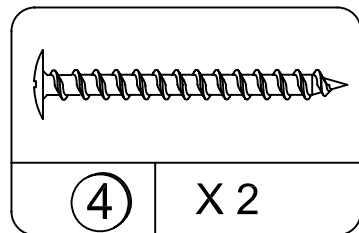
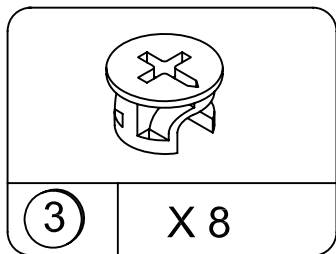
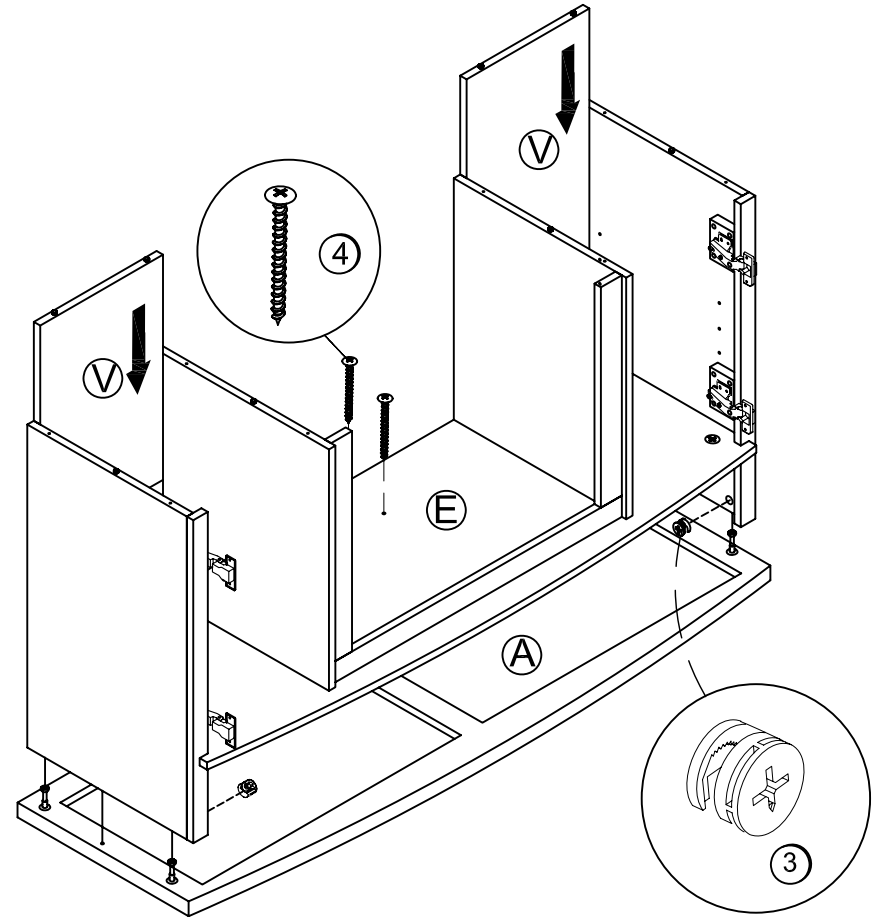
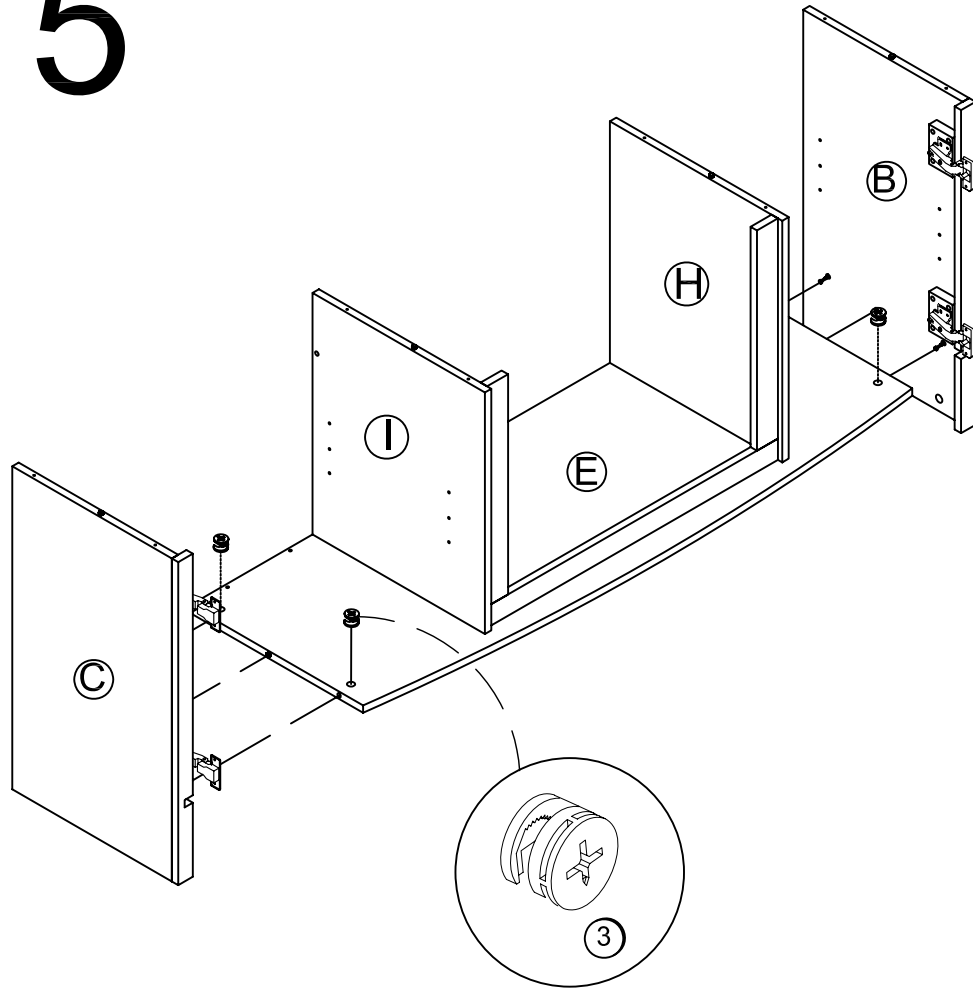

Proper orientation of CAM LOCK
 ORIENTACION APROPIADA DEL SEGURO DE LA CERRADURA
 Bonne orientation de la serrure de came.

6

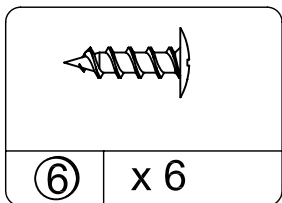
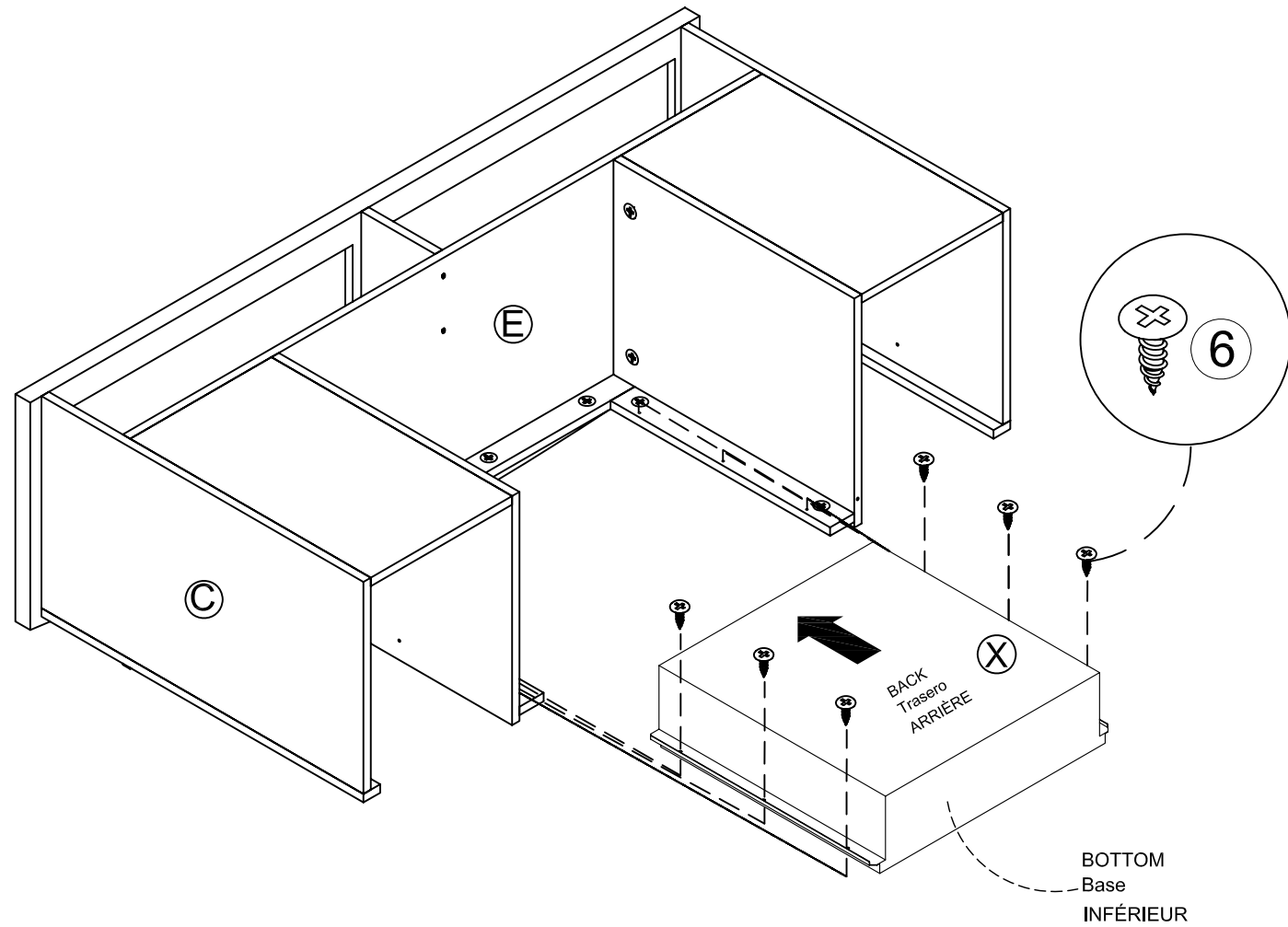

7

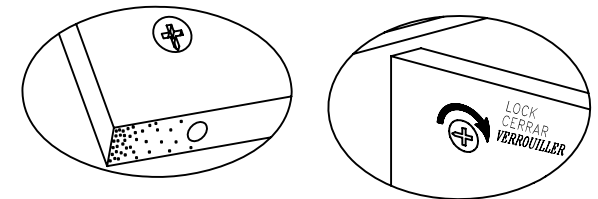
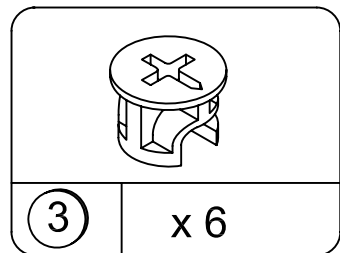
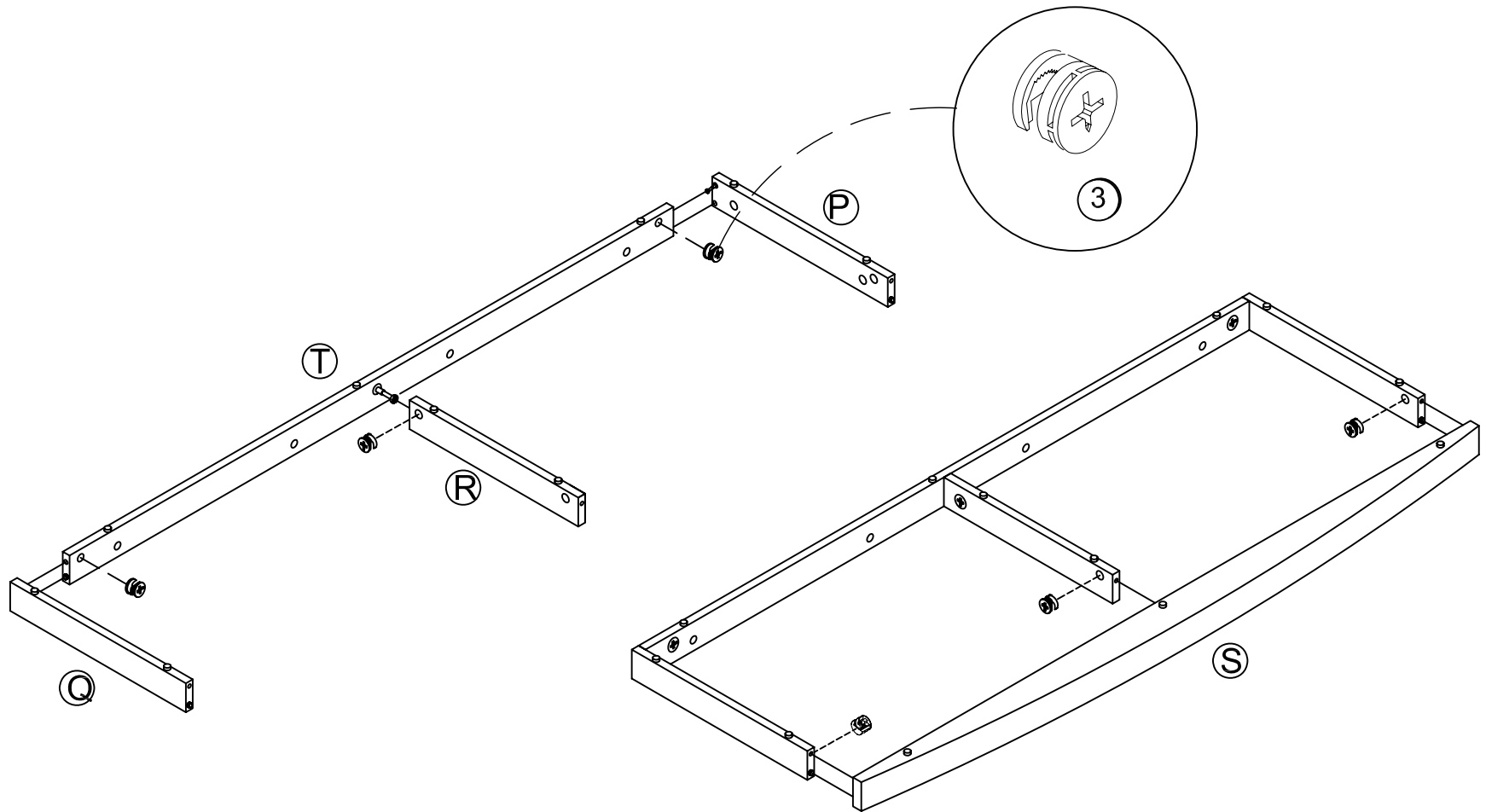

Proper orientation of CAM LOCK
ORIENTACION APROPIADA DEL SEGURO DE LA CERRADURA
Bonne orientation de la serrure de came.

8

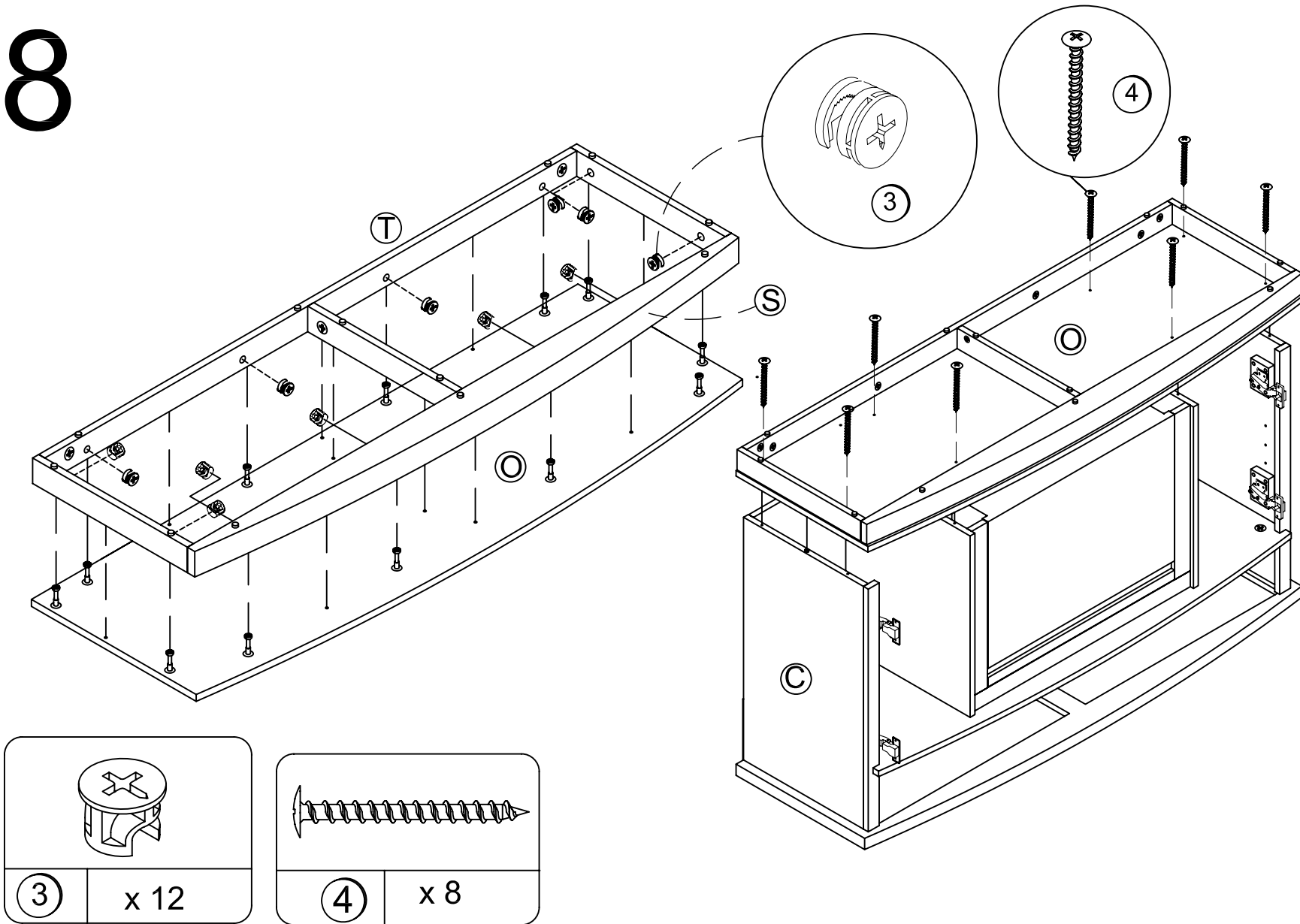

9

▲ WARNING

Please make sure that the backs are attached securely. All nails must be driven into the parts straight and tightened firmly. Failure to do so could cause instability, product collapse, and/or serious injury.

▲ ADVERTENCIA

Por favor asegúrese que las partes de atrás se atan firmemente. Todas las clavos deben manejarse en las partes recto y deben apretarse firmemente. El fracaso para hacer para que podría causar inestabilidad, derrumbamiento del producto, y/o la lesión seria.

▲ AVERTISSEMENT

S'il vous plaît assurez-vous que les Derrières sont attachés solidement. Tous les clous doivent être conduits dans les parties droit et doivent être serrés fermement. Échec de faire donc pourrait causer instabilité, chute subite du produit and/or blessure sérieuse.

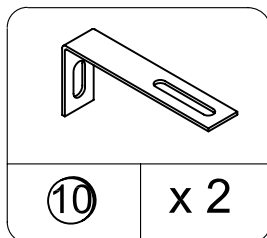
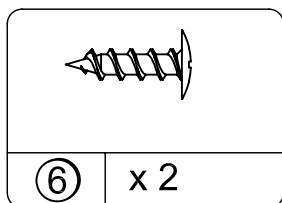
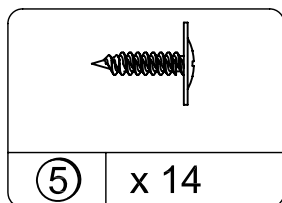
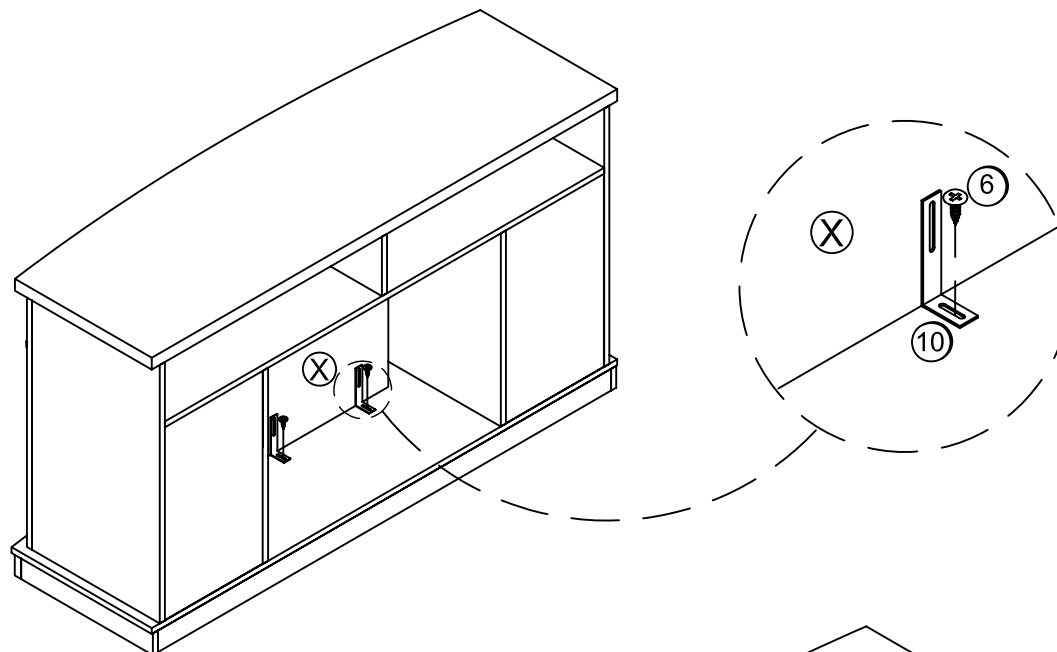

Before attaching the back panel, be sure that the unit is at 90°.

Antes de unir el panel trasero, asegúrese que la unidad este a 90 grados o en ángulo recto.

Avant de fixer le panneau arrière, assurez-vous que l'unité est à 90°.

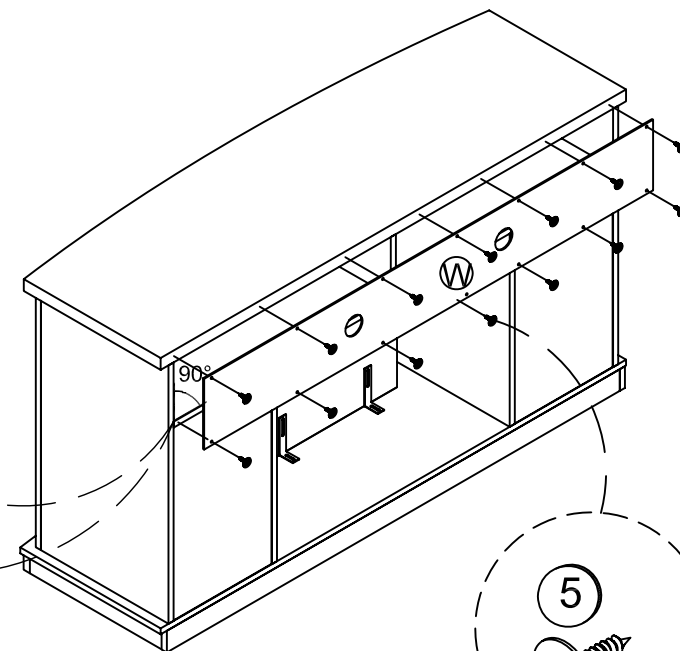

10

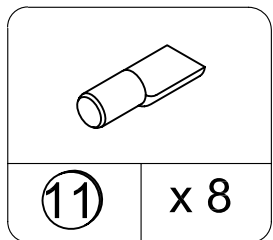
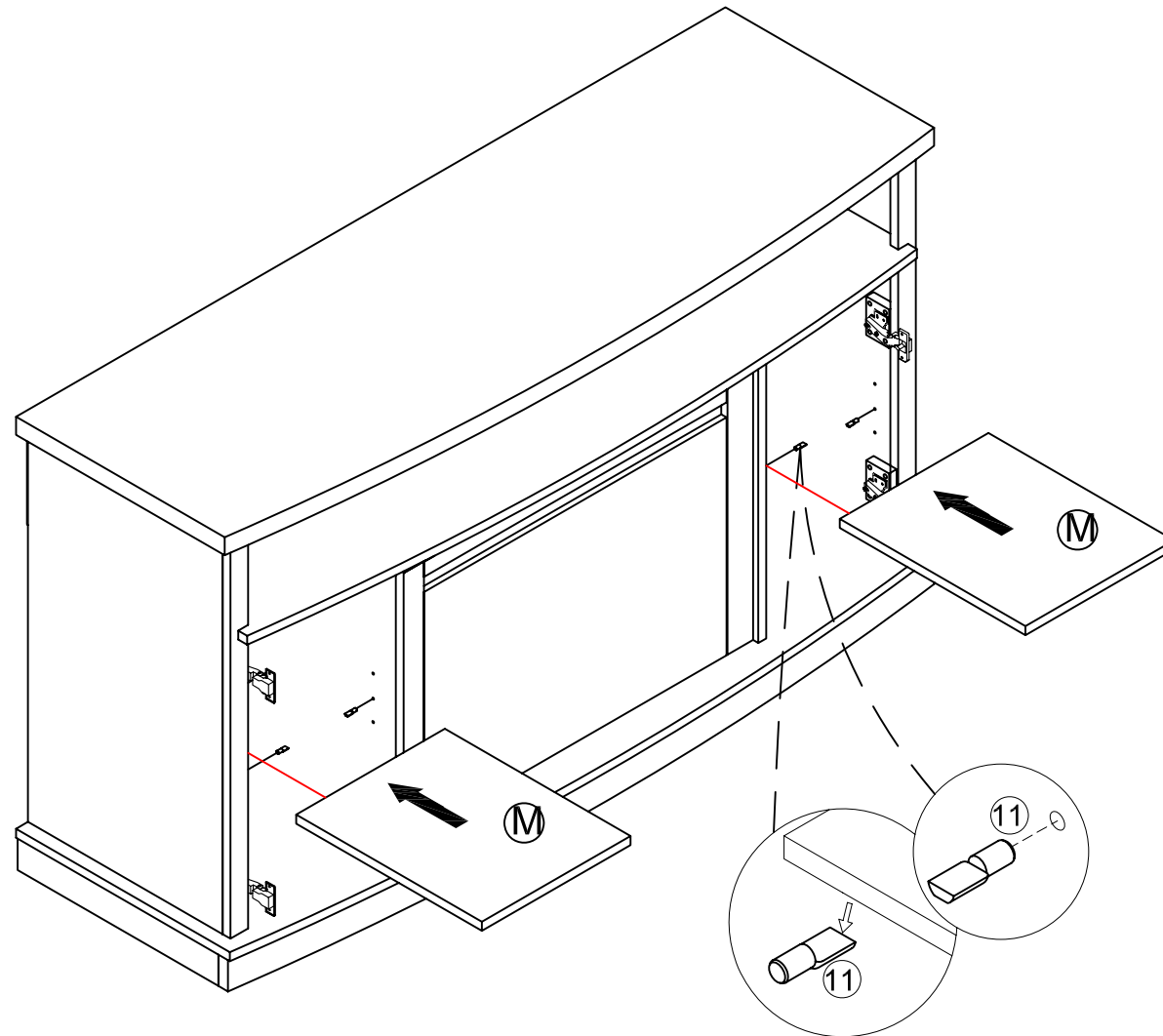

11

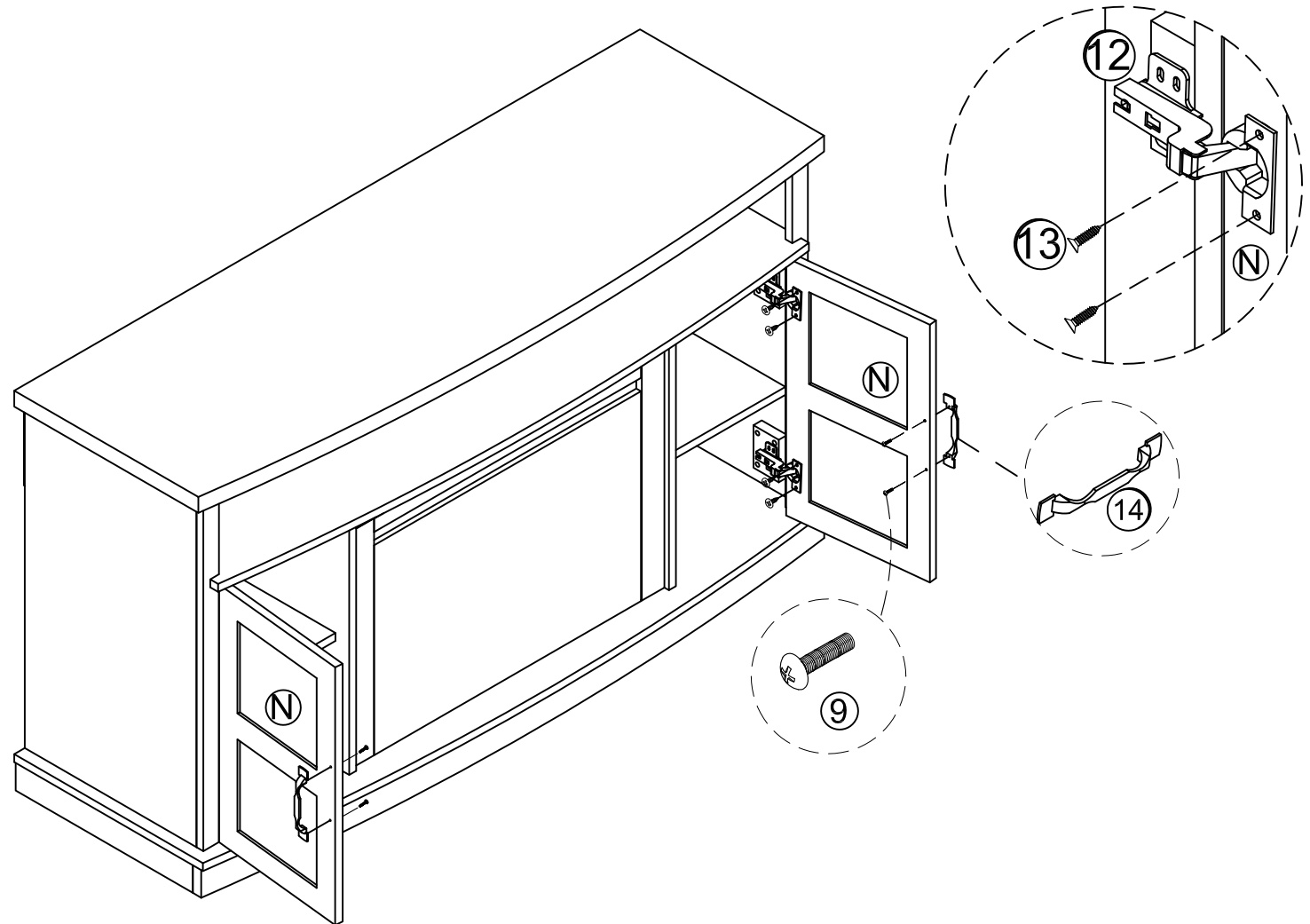
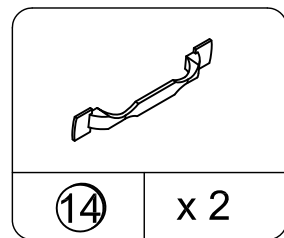
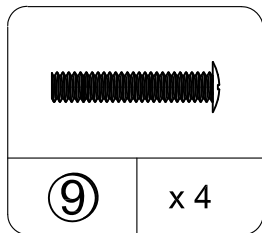
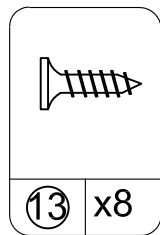

12

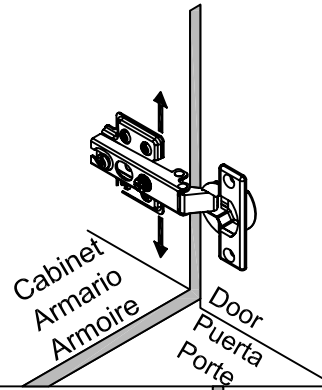
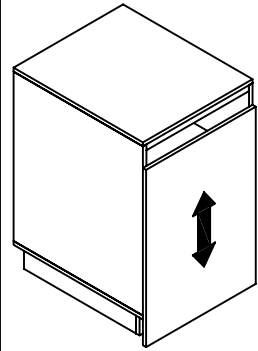
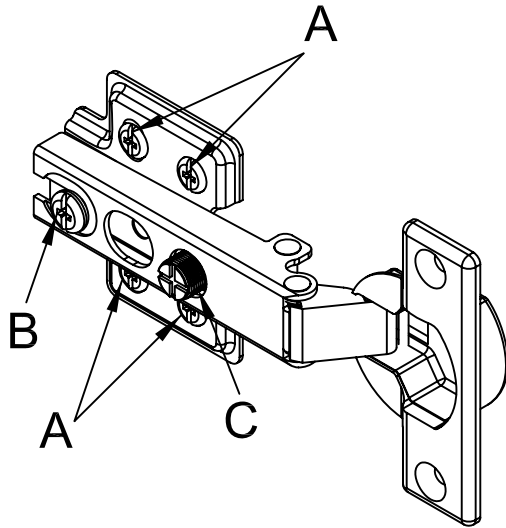

To adjust the vertical height.

Loosen the four screws "A" on both hinges. Two of them are usually in slotted holes which allows you to adjust up or down by a few mm. Then tighten back up.

Para ajustar la altura vertical.

Afloje los cuatro tornillos "A" en ambas bisagras. Dos de esos están usualmente en los agujeros llanos. Lo que significa que usted puede regular de arriba hacia abajo. Por unos pocos milímetros. Luego apriete hacia arriba.

Pour régler la hauteur verticale.

Desserrez les quatre vis "A" sur les deux charnières. Deux d'entre elles sont habituellement dans des fentes afin de vous permettre de les ajuster vers le haut ou le bas de quelques mm. Resserrez les vis après l'ajustement.

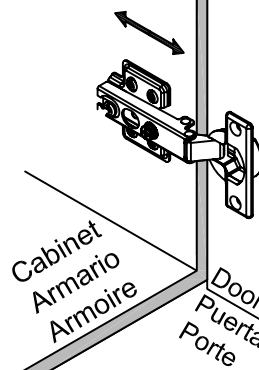
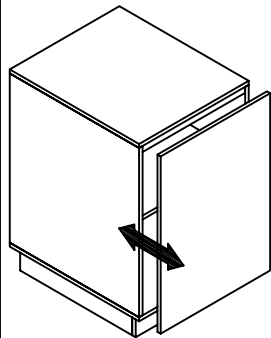

To adjust depth.

Loosen screw "B" and adjust door, if the door can not be adjusted, please loosen screw "C", then try again. Tighten screw "B" and "C".

Para ajustar profundo.

Afloje los tornillos y ajuste la puerta, si la puerta no puede ser ajustada. Por favor afloje los tornillos "C" y luego trate otra vez. Apriete los tornillos "B" y "C".

Pour régler la profondeur.

Desserrez la vis "B" et ajustez la porte. Si la porte ne peut pas s'ajuster, desserrez la vis "C", puis essayez de nouveau. Serrez les vis "B" et "C".

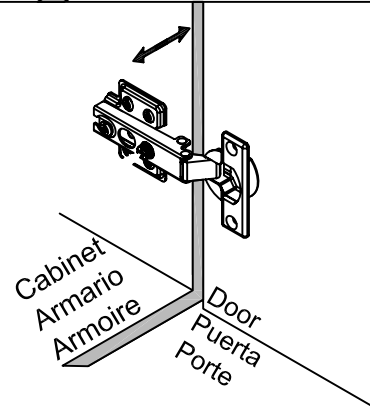
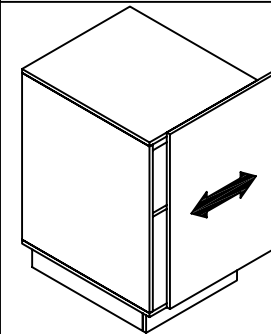

To adjust side ways.

Turning the screw "C" on BOTH hinges on each door.

Para ajustar los lados marcados

Gire los tornillos "C" de ambas bisagras en cada puerta

Pour régler latéralement.

Tournez la vis "C" sur les DEUX charnières de chaque porte.

13

BEFORE CONNECTING THE UNIT TO A WALL ELECTRIC OUTLET

Please carefully read and follow instructions and safety warnings in "Fireplace Homeowners Operating Manual" to operate your fireplace.

ANTES DE CONECTAR LA UNIDAD A UNA TOMA DE CORRIENTE ELÉCTRICA

Por favor lea detenidamente y siga las instrucciones y advertencias de seguridad en el "Manual Operativo para Propietarios de Chimenea " para funcionar su chimenea.

AVANT DE BRANCHER L'APPAREIL À UNE PRISE ÉLECTRIQUE MURALE

Veillez lire et suivre attentivement les instructions et les mises en garde de sécurité dans le "Mode d'emploi du Manuel du propriétaire du Foyer" pour faire fonctionner votre foyer.

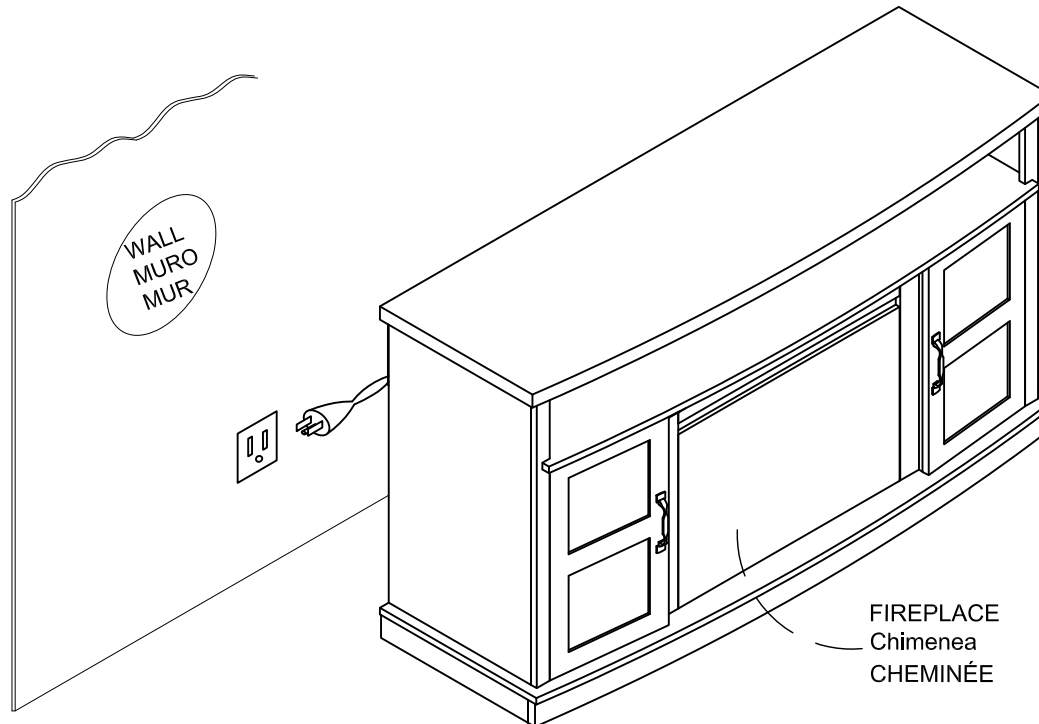

WARNING

IF THE INFORMATION IN THE FIREPALCE OPERATING MANUAL IS NOT FOLLOWED, AN ELECTRIC SHOCK OR FIRE MAY RESULT IN PROPERTY DAMAGE, PERSONAL INJURY , OR LOSS OF LIFE .

ADVERTENCIA

SI NO SIGUE LA INFORMACIÓN EN EL MANUAL OPERATIVO PARA PROPIETARIOS DE CHIMENEA, UNA DESCARGA ELÉCTRICA O UN INCENDIO PUEDE RESULTAR EN DAÑO DEL PRODUCTO, LESIONES PERSONALES O MUERTE.

MISE EN GARDE

SI LES INFORMATIONS DANS LE MANUEL DU PROPRIÉTAIRE DU FOYER NE SONT PAS SUIVIES ATTENTIVEMENT, UN CHOC ÉLECTRIQUE OU UN INCENDIE PEUT SE PRODUIRE ET CAUSER DES DOMMAGES MATÉRIELS, DES BLESSURES, OU DES PERTES DE VIES.

14

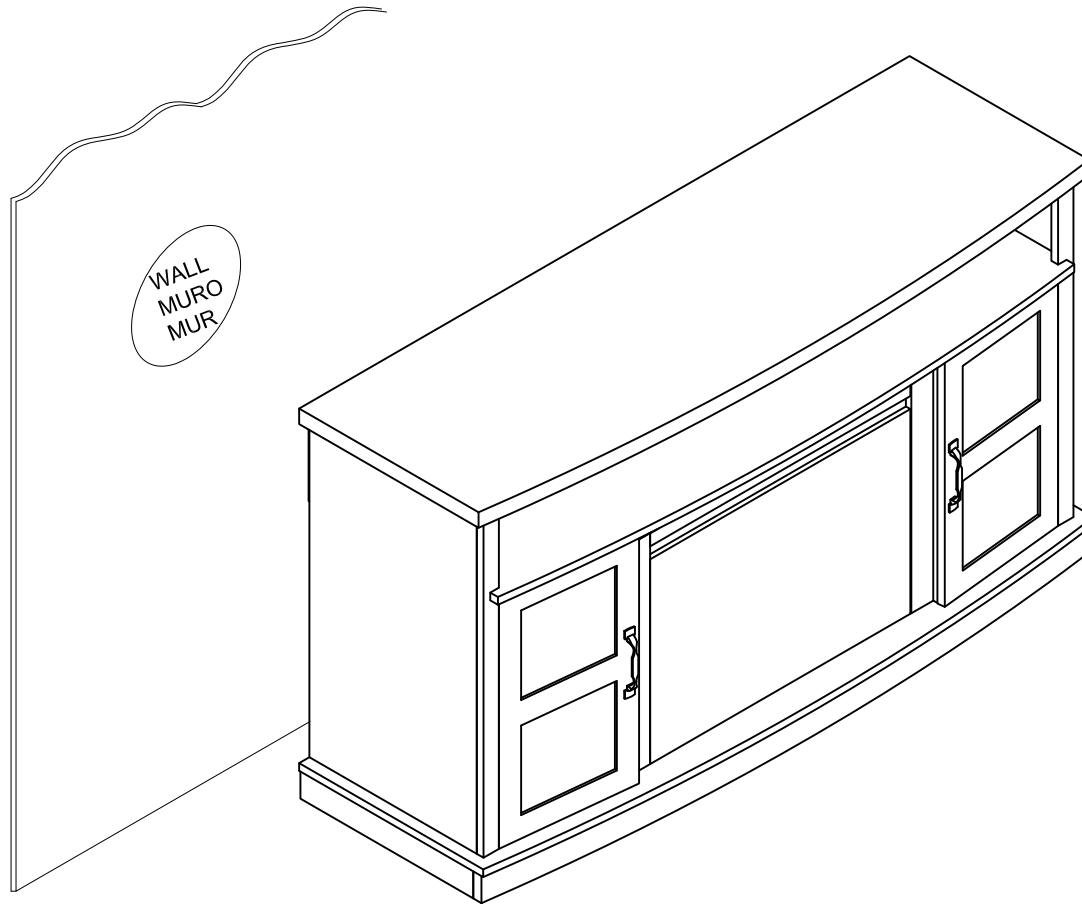

WARNING

Risk of death or serious injury. This unit must be placed against a fixed in place wall at least as tall as television.

ADVERTENCIA

Riesgo de muerte o lesión. Esta unidad debe ser colocada frente a una pared y debe ser instalada por lo menos a la misma altura que una televisión.

AVERTISSEMENT

Danger de mort ou de blessures graves. Cette surface doit être placée contre un mur fixé en place au moins aussi grand que la télévision.

WEIGHT LIMITS :
LIMITES DE PESO :
LIMITES DE POIDS :

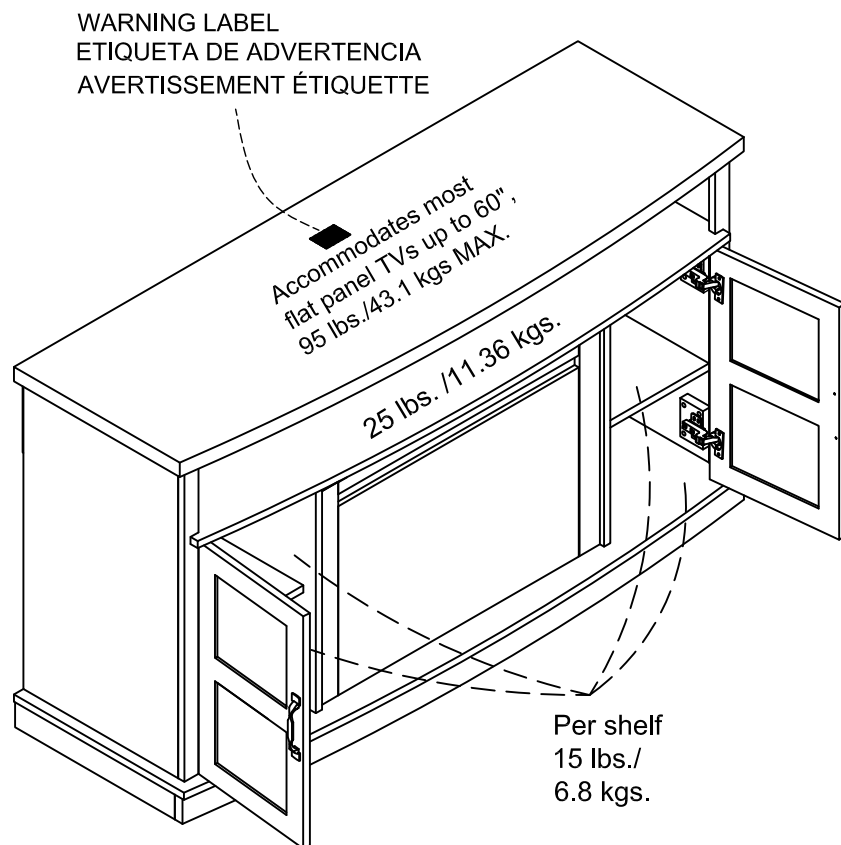

Enjoy your furniture.
Disfrute de su mueble.
Profitez de votre meuble.

This unit has been designed to support the maximum loads shown. Exceeding these load limits could cause sagging, instability, product collapse, and/or serious injury.

Esta unidad ha sido diseñada para soportar una carga máxima como se muestra. Excederse en los límites de cargas o sobre peso puede ocasionar inestabilidad, flacidez, y el derrumbamiento del mueble y ocasionar lesiones

Ce meuble a été conçu pour soutenir les charges maximum indiquées. Si ces limites sont dépassées, le meuble peut fléchir, devenir instable, s'effondrer et causer des blessures graves.

▲ WARNING

Please make sure that all the objects are removed before moving the assembled unit. The unit must be lifted by more than one person, not dragged or pushed. Failure to do so will cause product damage, instability, product collapse, and/or serious injury.

▲ ADVERTENCIA

Por favor, asegúrese de que todos los objetos sean removidos antes de mover la unidad ensamblada. La unidad debe ser levantada por más de una personas no arrastrada o empujada. No hacerlo podría causar la destrucción del mueble, inestabilidad y provocar severas lesiones.

▲ AVERTISSEMENT

Veuillez vous assurer d'enlever tous les objets du meuble avant de le déplacer. Le meuble doit être soulevé en équipe et non traîné ou poussé. Si vous ne respectez pas cette directive, le meuble peut se briser, devenir instable, s'effondrer et entraîner des blessures graves.