

SPOL 1628-15 LIFT COCKTAIL TABLE (SKU#22116289)

ASSEMBLY INSTRUCTION

Thank you for purchasing this quality product. Be sure to check all packing material carefully for small parts which may have come loose inside the carton during shipment. Identify and count all parts and compare with the Parts list below:

HARDWARE LIST			
NO.	PART	DESCRIPTION	Q'TY
A		BOLT:Ø5/16"*2" (18 Threads per inch.)	6
		LOCK WASHER:Ø5/16"	6
		WASHER:Ø5/16"*19mm	6
B		BOLT:Ø1/4"*5/8"	8
		LOCK WASHER:Ø1/4"	8
		WASHER:Ø1/4"*16mm	8
C		BOLT:Ø1/4"*1/2"	2
D		ALLEN WRENCH:5mm	1
E		ALLEN WRENCH:4mm	1
F		CASTOR	4
G		IRON BRACKET	4
H		HEX	1

PARTS LIST			
NO.	PART	DESCRIPTION	Q'TY
1		TOP FRAME	1
2		SHELF	1
3		LEG	3
4		MIDDLE LEG	1

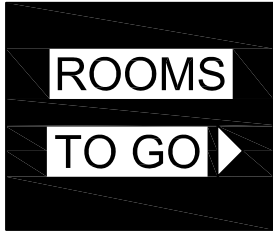

SPOL 1628-15 LIFT COCKTAIL TABLE (SKU#22116289)

ASSEMBLY INSTRUCTION

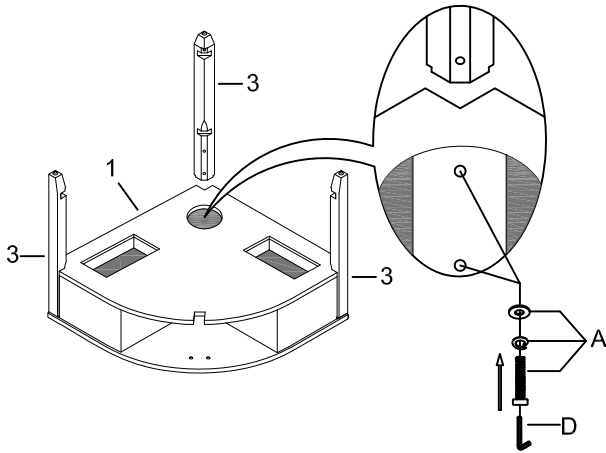

step 1

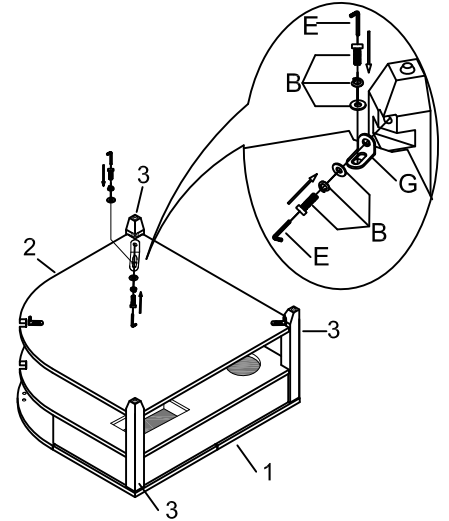

step 2

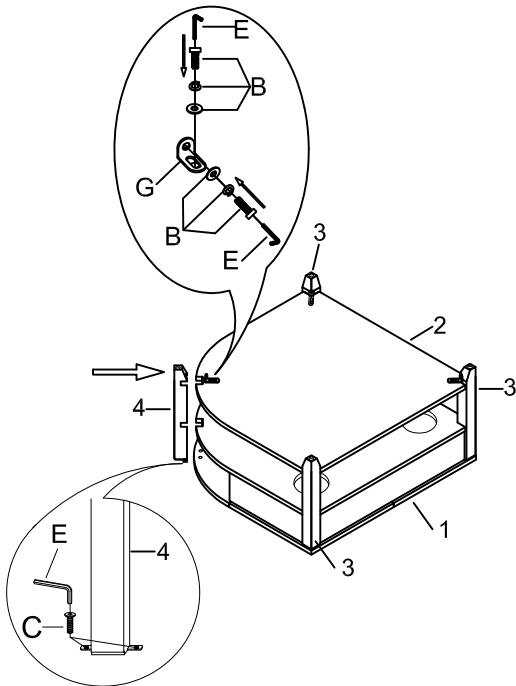

step 3

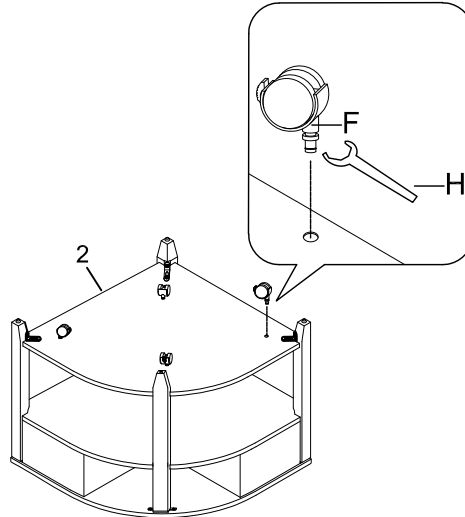

step 4

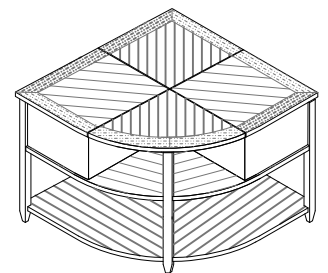

step 5

ASSEMBLY INSTRUCTION

- 1) carefully take the lift top assembly out of carton and place it on a clean soft blanket. **Do not unwrap the protected film untill full assembly.**
- 2) Place the lift top assembly upside down, attach 3 pcs leg (No.3) to the lift top assembly using A,D, but do not tighten 100%, as shown in step 1.
- 3) attach bottom panel (No. 2) using B,E,G as step 2.
- 4) attach leg (No 4) using E,C as step 3.
- 5) attach casters (No, F) using H.
- 6) Attach the castors on the bottom shelf by using F, as shown in step 4.
- 7) unwrap the protected film after full assembly .
- 8) Enjoy your table for a long time to come.

MADE IN CHINA