

ASSEMBLY INSTRUCTIONS

MIYO 92321-2 END TABLE SKU# 23009233

Caution: Please read instructions thoroughly before unpacking assembly parts. Sharp, exposed staple tips can cause injury, therefore, for your protection, please remove any exposed staple used in packing.

1. We recommend that you should assemble this product with the assistance of another person; this will make assembly easier, and will help to eliminate damage to the product or injury to persons during assembly.
2. Be sure to check all packing materials carefully for small parts that may have come loose inside the carton during shipment.
3. Please do not over tighten screws or bolts.
4. Please put all parts on a non-abrasive floor before assembly, and follow the assembly steps to assemble your newly purchased product correctly and efficiently.

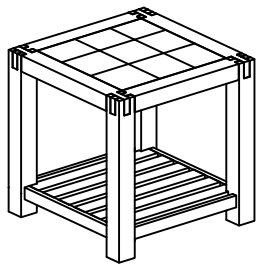

HARDWARE LISTS			
NO.	OUTLOOK	SIZE	Q'TY
A		Allen Bolt Ø5/16" x 18 x 2-1/2"	10PCS
		Spring Washer Ø5/16"	10PCS
		Flat washer Ø5/16" x 19mm x 2mm	10PCS
B		Allen Wrench 4mm	1PC

PART LISTS			
NO.	SKETCH	DESCRIPTION	Q'TY
1		TABLE TOP	1PC
2		TABLE LEG	2PCS
3		SHELF	1PC

HARDWARE PACK LOCATION (1) 92321-2 END TABLE SKU#23009233

STEP 1

Place the Table Top (1) bottom side up carefully. Secure Table Leg (2) to the Table Top (1) with Allen Bolt, Spring Washer and Flat Washer (A) using Allen Key (B), do not tighten all bolts at this time.

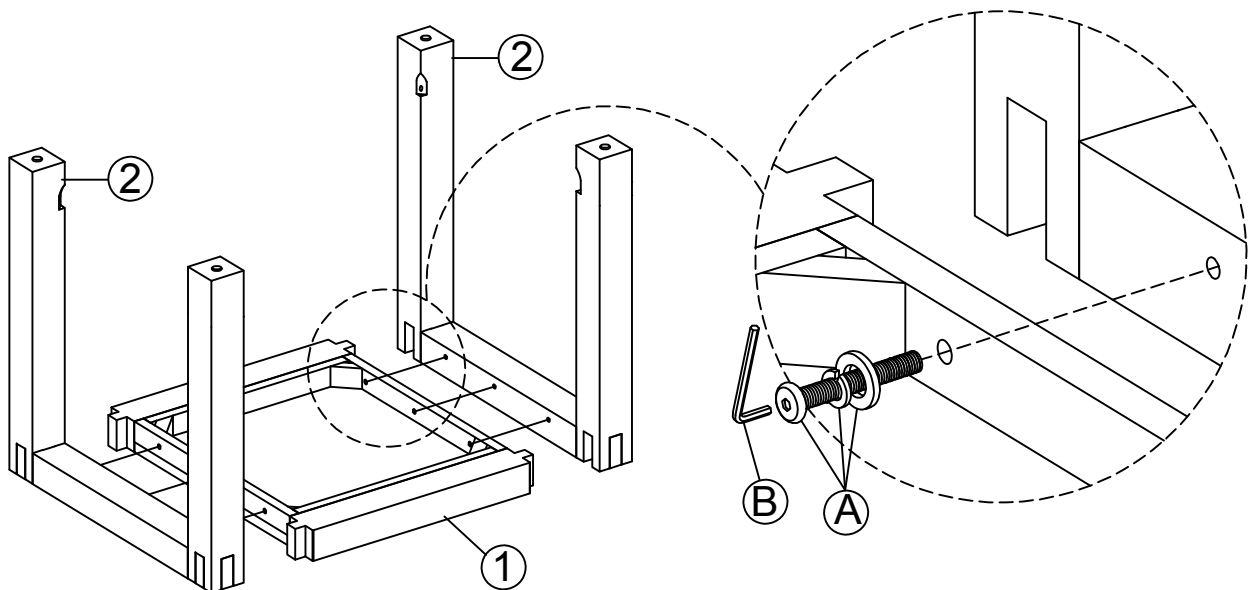

This product is manufactured by MIYO for ROOMS TO GO®

ASSEMBLY INSTRUCTIONS

MIYO 92321-2 END TABLE SKU# 23009233

STEP 2

Attach the Shelf (3) to the Table Leg (2) with Allen Bolt, Spring Washer and Flat Washer (B) using Allen Key (B).

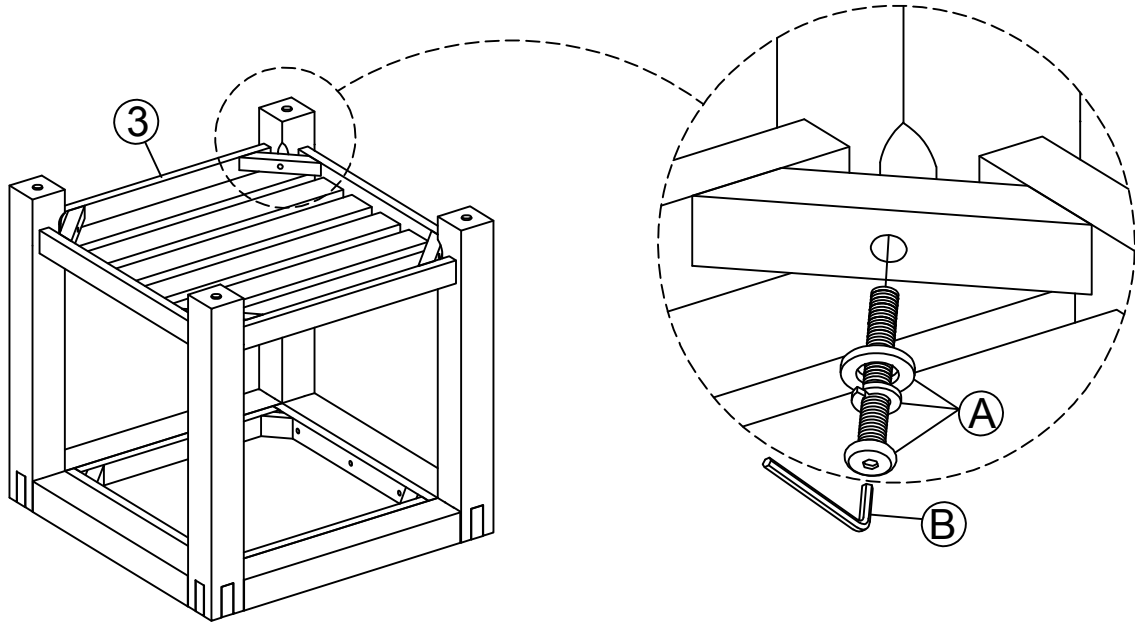

STEP 3

Ensure that it is level and square and tighten all bolts using Allen Key (C).

ASSEMBLY IS COMPLETED.

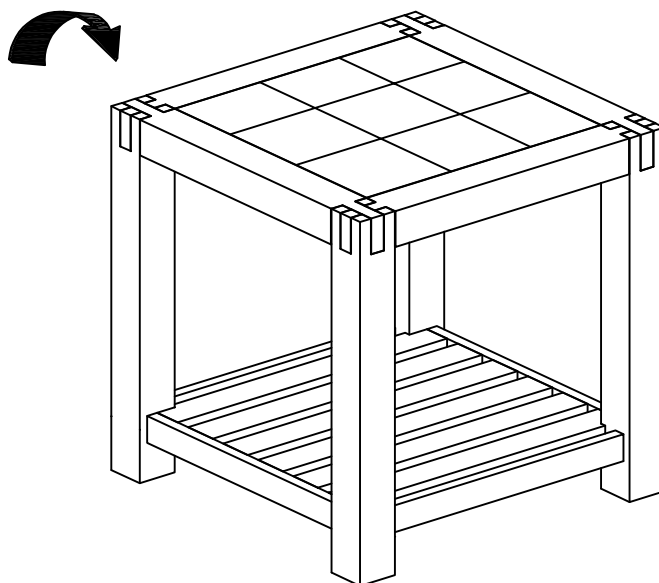

This product is manufactured by MIYO for ROOMS TO GO®