

# Assembly Instructions

FRNR 2128-06  
2129-06  
End table







SKU# 23022281  
SKU# 23022293

Manufactured By FRNR For Rooms To Go



Version: 1.0

1/2025

## Hardware List

Step	Code	Description	Q'TY
1	A	Bolt M6X10mm 	2Pcs
1	B	Allen Key 4mm 	1Pc
2	C	Flat Washer Ø16X1.5mm 	4Pcs
		Spring Washer Ø13X2.5mm 	4Pcs
		Bolt M8X40mm 	4Pcs
2	D	Allen Key 6mm 	1Pc

## Part List

Step	Code	Description	Q'TY
1	1	Frame 	2Pcs
1	2	Connect tube 	1Pc
2	3	Top 	1Pc

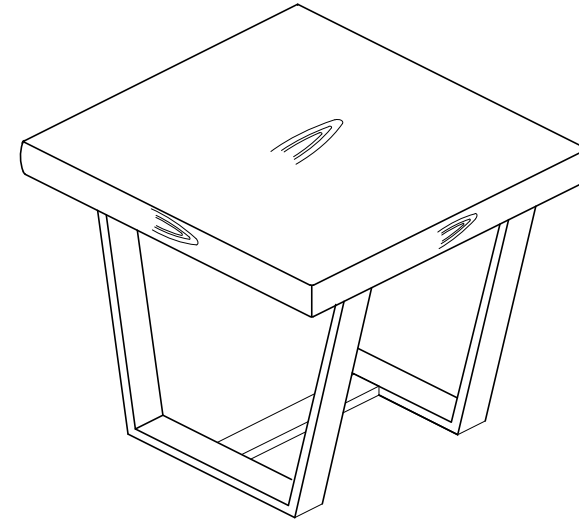

Hardware Pack Location(s):  
End table, SKU# 23022281  
SKU# 23022293

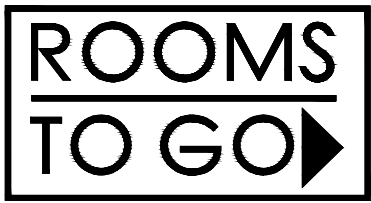

# Assembly Instructions

FRNR 2128-06  
2129-06  
End table

SKU# 23022281  
SKU# 23022293

Manufactured By FRNR For Rooms To Go

Version: 1.0

1/2025

**\*\*\* Caution:** Please read all instructions carefully before starting the assembly process. These parts are cumbersome and heavy. Therefore, two people are recommended in order to prevent personal injury and insure the parts are not damaged during the assembly

## STEP1:

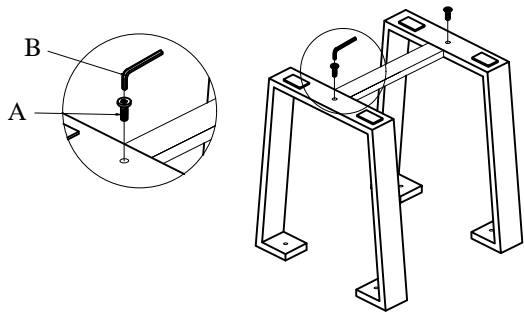

Lay the metal frames upside down, on a carpeted or protective surface, to avoid damage. Attach the stretch between the two frames by using the provided screws.

## STEP2:

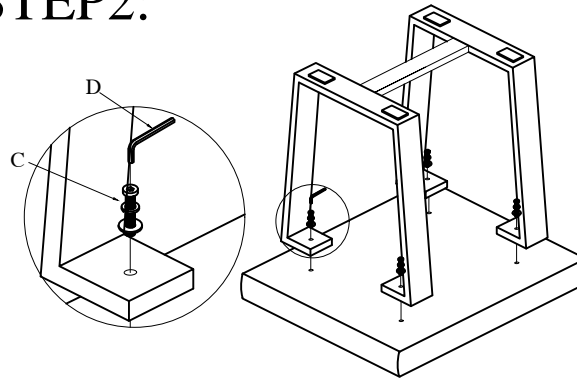

Lay the table top upside down, on a carpeted or protective surface, to avoid damage. Attach the legs, using the provided screws and washers, aligning the holes, into the threaded inserts, tighten securely.

## Finsh:

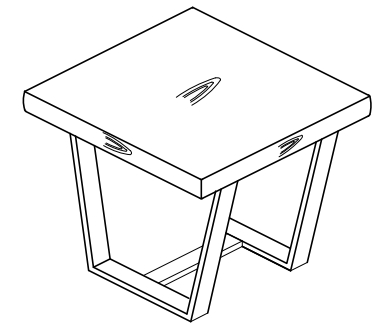

Stand the table upright.