





ASSEMBLY INSTRUCTIONS

FNR5085 Pembroke End Table





Manufactured by (CPLX) for RTG

SKU#: 23050848

PARTS

S.NO	DESCRIPTION	QTY.
A	 TOP	1
B	 LEG	2

HARDWARE

S.NO	DESCRIPTION	QTY.
C	 ALLEN KEY (4 MM)	1
D	 BOLT (M6X16 MM)	8
E	 BOLT (M6X20 MM)	1
F	 WASHER (20 MM)	5

STEP 1:

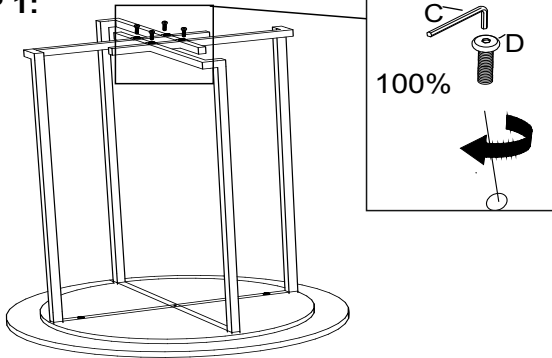

Place Top upside down on soft, flat surface to prevent damage. Align Legs (B) tighten using Small Allen Bolt (D),

STEP 2:

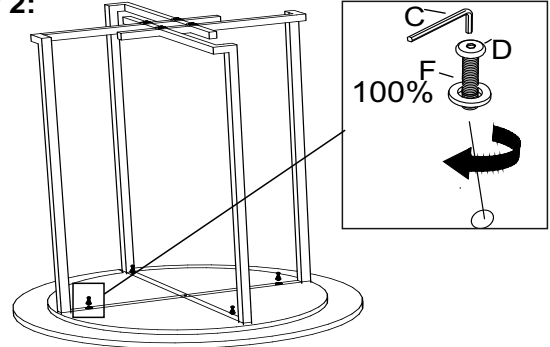

Align Legs (B) with bottom of Top (A). tighten using Small Allen Bolt (D), Washers (F).

STEP 3:

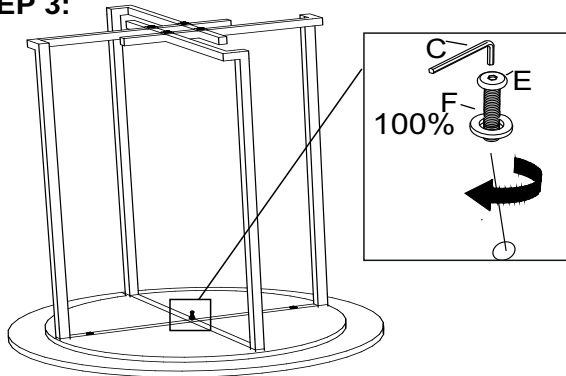

Tighten using large Allen Bolt (E), Washers (F).

STEP 4:

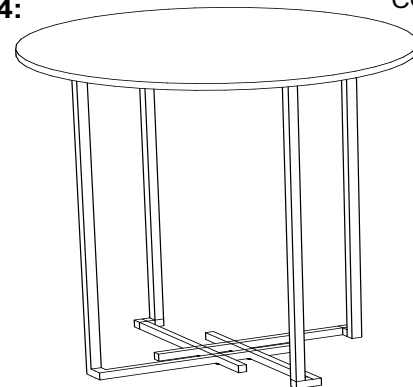

COMPLETE