



ASSEMBLY INSTRUCTIONS

HMVN: 5152-ETW END TABLE W/ WOOD TOP
SKU#: 23051523







Manufactured by HMVN for Rooms To Go

Version # 01- 03/21/2024

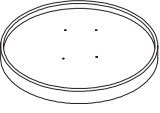
Thank you for purchasing this product. Be sure to check all packing material carefully for small parts which may have come loose inside the carton during shipment. Identify and count all parts and compare with the HARDWARE LIST below.

Caution: Please read all instructions carefully before starting the assembly process. These parts are cumbersome and heavy. Therefore, two people are recommended in order to prevent personal injury and insure the parts are not damaged during the assembly.

PARTS LIST

			
A. FACE TOP - 1PC	B. SQUARE BRACKET - 1PC	C. BOTTOM ROUND BASE=1PC	D. ROUND PILLAR =1PC
NO.	HARDWARE LIST	Q'TY	<p>Hardware pack locations: 5152-ETW End TBL w/Wood Top -sku#:23051523</p> <p>Note: Do not tighten all screws & Bolts until the table is fully assembly.</p>
1	 BOLT 5/16*18*28mm SPRING WASHER 5/16*Ø14*1.5mm FLAT WASHER 5/16*Ø19*2mm	4 PCS	
2	 BOLT 1/4*20*15mm SPRING WASHER 1/4*Ø12*1.5mm FLAT WASHER 1/4*Ø16*2mm	4 PCS	
3	 ALLEN KEY M4	1 PC	

STEP 1: Assemble the Square Bracket (B) to the Round Pillar (D) by bolt (1) and tighten with Allen key (3).

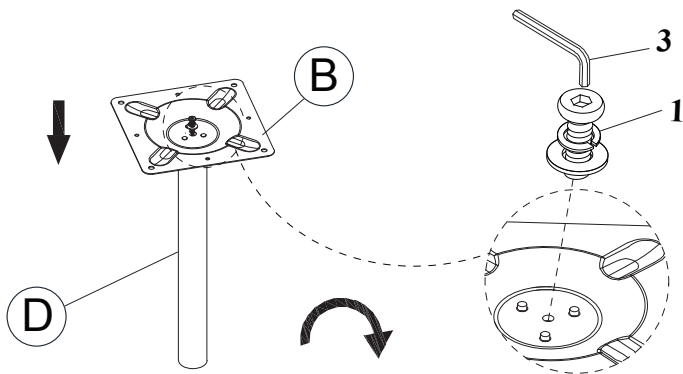

STEP 2: Assemble the STEP 1 to the Top table (A) by bolt (2) and tighten with Allen key (3).

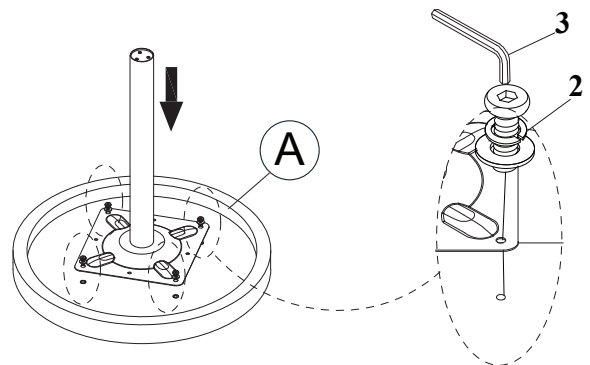

STEP 3: Assemble the Bottom round table by bolt (1) and tighten with Allen key (3).

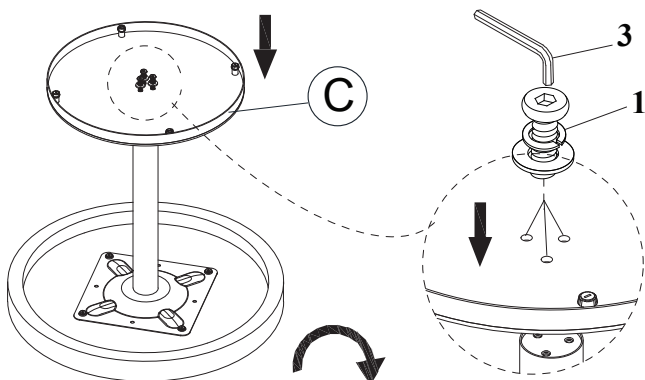

STEP 4:

