



# ASSEMBLY INSTRUCTION

## E816A SIDE TABLE

<b>A</b> Wood Top  1pc	<b>B</b> Base  1pc	<b>C</b> Side Panel  1pc
<b>D</b> Metal Bar  2pcs	<b>E</b> Bolt 1/4" x 1/2"  8pcs	<b>F</b> Leveler 12mm  2pcs
<b>G</b> Allen Wrench 1/4"  1pc		

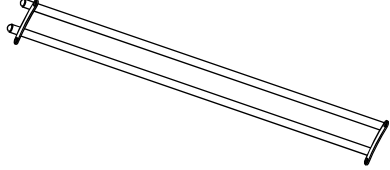
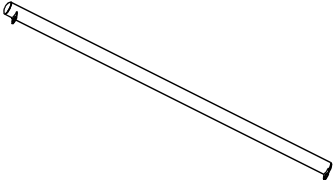
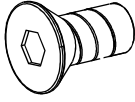
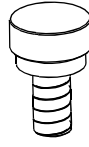
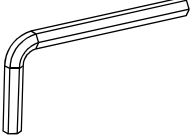
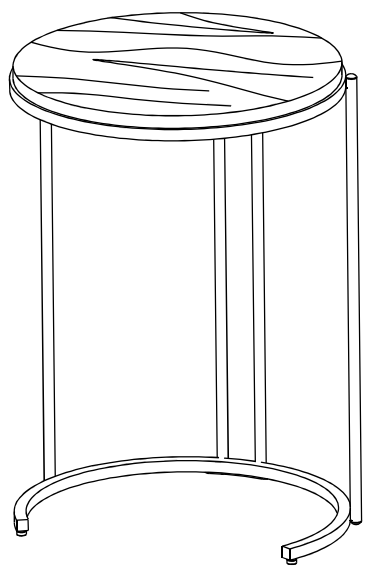

This page lists all the contents included in the box. Please take the time to identify the hardware as well as the individual components to this product. As you unpack and prepare for assembly, place the contents on a carpeted or padded area to protect them from damage.

**\*\*\* Do not tighten screws & bolts until the entire unit is completely assembled.**

**1**

Attach Side Panel (C) and Metal Bar (D) to Wood Top (A) by Bolt (E) and Allen Wrench (G) as shown.

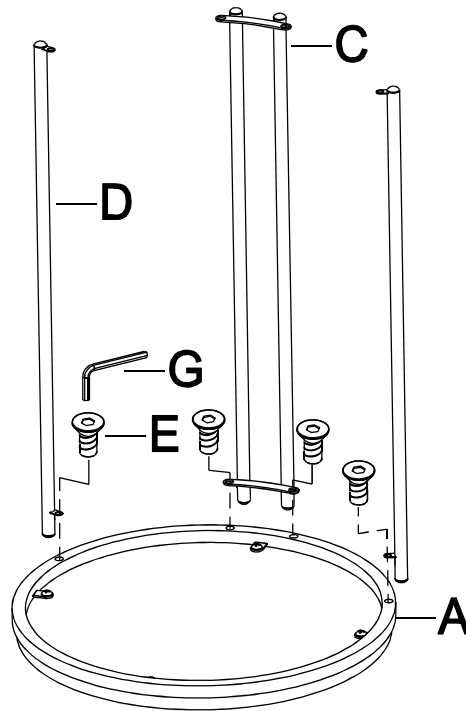

**2**

Attach Base (B) to Side Panel (C) and Metal Bar (D) by Bolt (E) and Allen Wrench (G). Then attach Leveler (F) to Base (B) as shown.

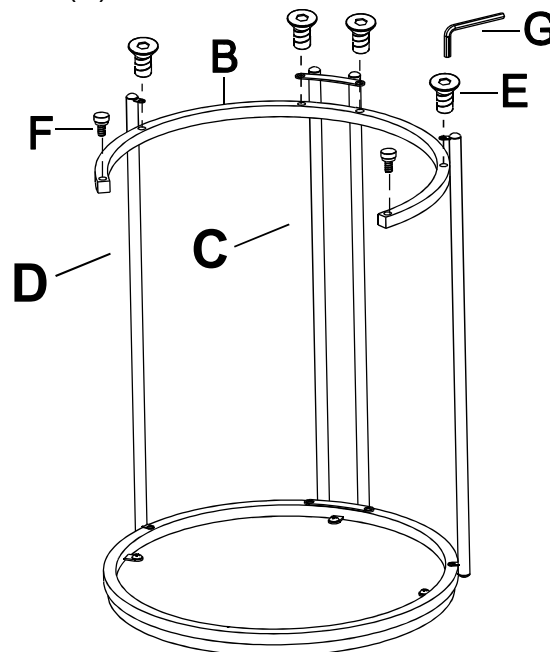

### Cleaning & Care

Treat surface with care. Surface is resistant to scratches but is not scratch resistant. Clean surfaces with a dry or damp soft cloth. Do not use abrasive cleaners. Hardware may loosen over time. Periodically check that all connections are tight.