



ASSEMBLY INSTRUCTIONS

NEFS EFS-4-ETE END TABLE SKU#23100047

NEFS EFS-4-ETW END TABLE SKU#23100059





Manufactured by NEFS for Rooms To Go



Version 1 -08102025

Thank you for purchasing this quality product . Be sure to check all packing material carefully for small parts which may have come loose inside the carton during shipment . Identify and count all parts and compare with the HARDWARE LIST below .

Caution : Please read instructions thoroughly before unpacking assembly parts.

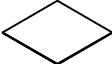
- 1.We recommend that you assemble this product with the assistance of the another person; this will make assembly easier, and will help to eliminate damage to the product or injury to persons during assembly.**
- 2.Please do not over tighten screws or bolts until the assembly is completed.**
- 3.Please put all parts on a non-abrasive floor before assembly, and follow the assembly steps to assemble your newly purchased product correctly and efficiently.**

NO.	PART LIST		Q'TY
A		Wooden Leg	4PCS
B		Wooden Bar	2PCS
C		Shelf Frame	1PC
D		Top Frame	1PC
E		Top Glass	1PC

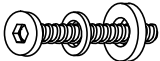
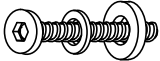
NO.	HARDWARE LIST		Q'TY
1		ALLEN KEY (4mm)	1PC
2		PLASTIC BUMPER 17*13*8mm	4PCS
3		BOLT Ø5/16"-18*76mm (PRE-ASSEMBLED)	4PCS
		SPRING WASHER Ø5/16"-13mm (PRE-ASSEMBLED)	4PCS
		FLAT WASHER Ø5/16"-19mm*2mm (PRE-ASSEMBLED)	4PCS
4		BOLT Ø5/16"-18*38mm (PRE-ASSEMBLED)	10PCS
		SPRING WASHER Ø5/16"-13mm (PRE-ASSEMBLED)	10PCS
		FLAT WASHER Ø5/16"-19mm*2mm(PRE-ASSEMBLED)	10PCS

Hardware pack locations: NEFS EFS-4-ETE END TABLE SKU#23100047
 NEFS EFS-4-ETW END TABLE SKU#23100059

NEFS EFS-4-ETE END TABLE SKU#23100047

NEFS EFS-4-ETW END TABLE SKU#23100059

Manufactured by NEFS for Rooms To Go

Version 1 -08102025

Thank you for purchasing this quality product . Be sure to check all packing material carefully for small parts which may have come loose inside the carton during shipment . Identify and count all parts and compare with the **HARDWARE LIST below .**

Caution : Please read instructions thoroughly before unpacking assembly parts.

Step 1: connect the legs (A) with the bar (B) by bolt set (4) and Allen key (1)

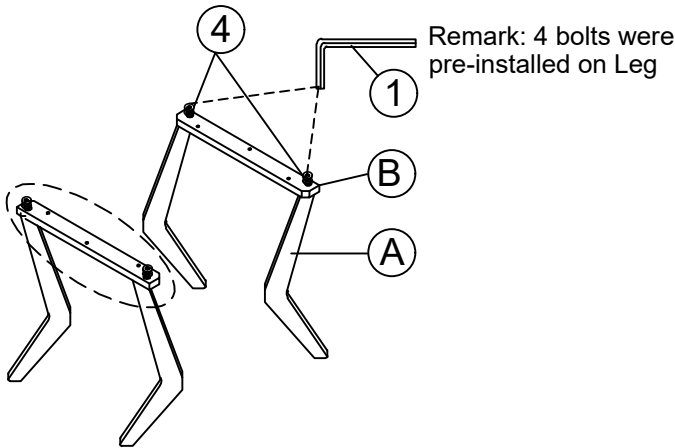

Step 2: connect step 1 with the Top Frame (D) by bolt set (4) and Allen key (1)

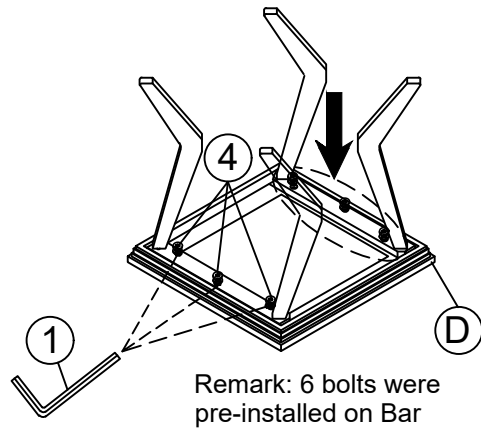

Step 3: connect step 2 with the Shelf Frame (C) by bolt set (3) and Allen key (1)

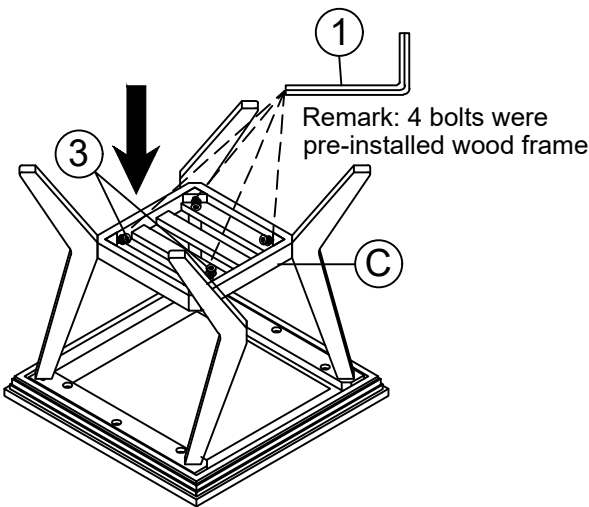

Step 4: put the Top Glass (E) on the Plastic Bumper (2) and the Top Frame (D)

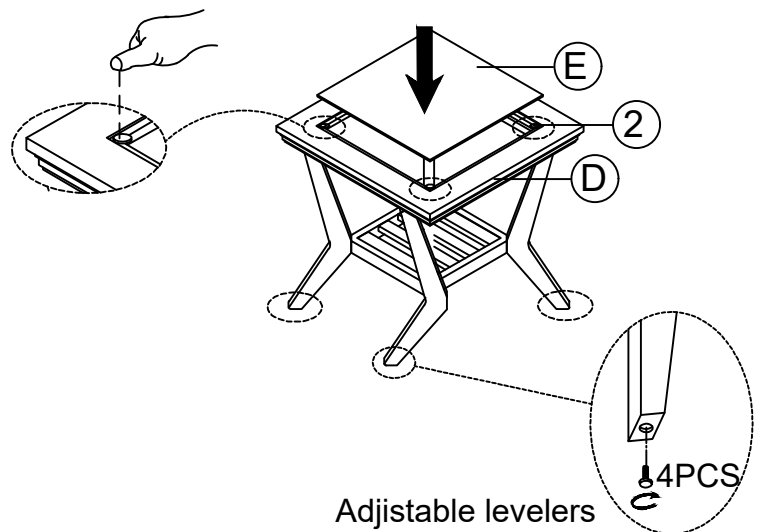

Hardware pack locations: NEFS EFS-4-ETE END TABLE
NEFS EFS-4-ETW END TABLE

SKU#23100047
SKU#23100059