





ASSEMBLY INSTRUCTIONS

SKU # 44622

Thank you for purchasing this quality product. Be sure to check all packing material carefully for small parts that may have come loose inside the carton during shipment.

HARDWARE LIST-

 Large Bolt = $\varnothing 0.23$ * 1.25" 8 PCS+ 1 PC extra	 Small Bolt = $\varnothing 0.23$ * 0.75" 4 PCS+ 1 PC extra	 Washer = $\varnothing 0.31$ " 12 PCS +1 PC extra	 Allen Key = $\varnothing 0.2$ " 1 PC	 Spring Washer = $\varnothing 31$ " 12 PCS + 1 PC extra
---	---	---	---	---

PARTS LIST-

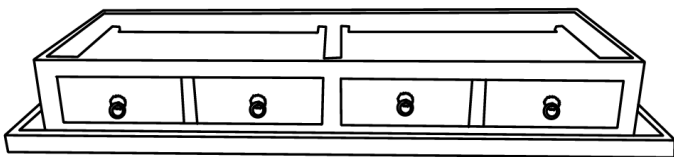

TOP- 1 pc

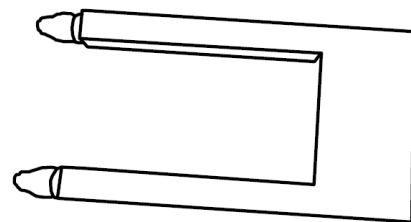

LEG- 2 pcs

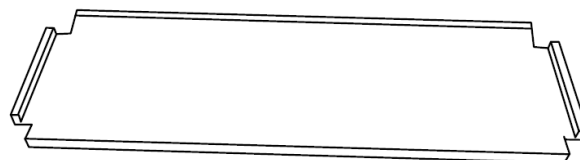

SHELF – 1 pc

PROCESS- Place the table top upside down on a flat surface. Open both the drawers'. Attach the table legs to the table top on shown in below pictures. Now insert one spring washer, one washer and one large bolt into holes of legs A, B and loosely tighten with Allen key then snug all bolts. Repeat the same process with Shelf part with small bolts and then snug all bolts.

Note: Don't tighten all bolts until the end of step 5.

STEP OF ASSEMBLY:-

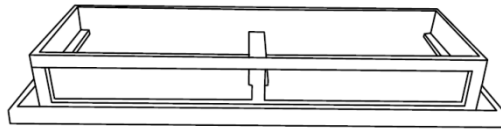

Step 1

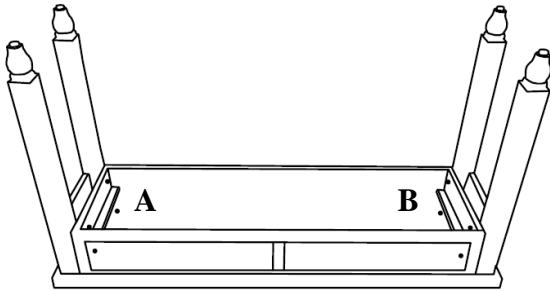

Step 2

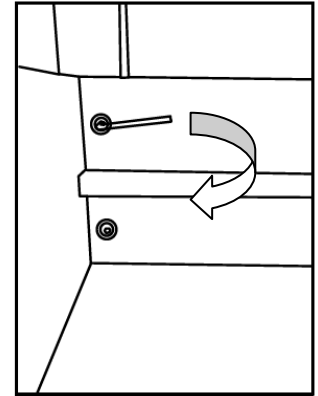

Step 3

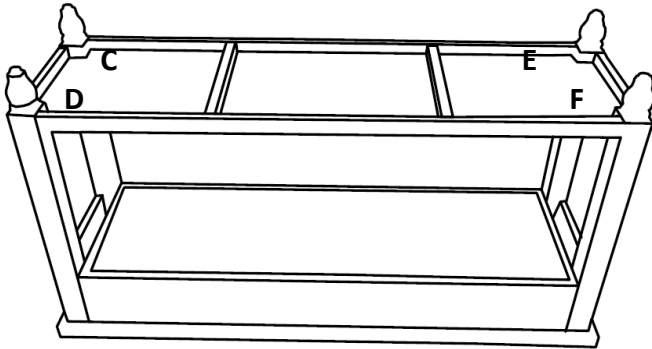

Step 4

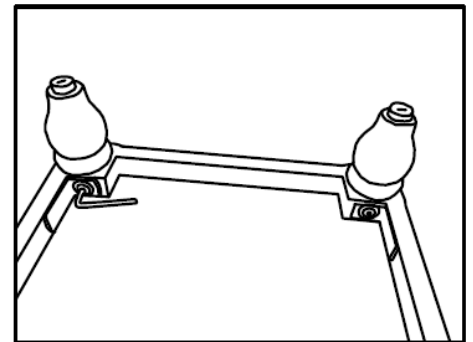

Step 5

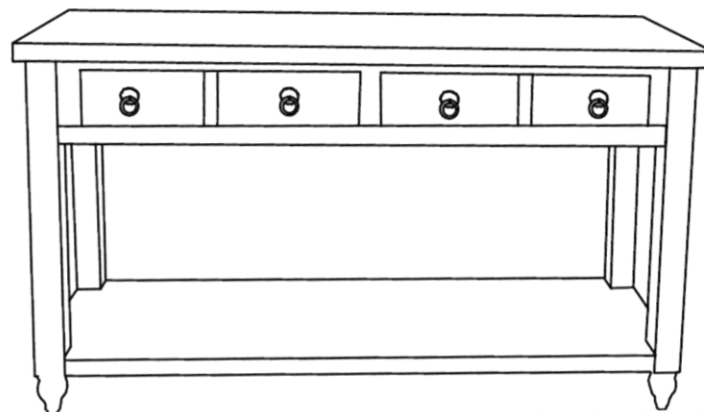

FINAL ASSEMBLED PICTURE

Tip for leveling of product: When the product rests on an uneven floor surface it will appear to be unbalanced. To aid in leveling, try adjusting the levelers located on the bottom of each foot.