



# ASSEMBLY INSTRUCTIONS

## RQUE 9852S - SOFA TABLE

### SKU: 23998529

Thank you for purchasing this product. Be sure to check all packing material carefully for small parts which may have come loose inside the carton during shipment. Identify and count all parts and compare with the **HARDWARE LIST** below.

Caution: Please read all instructions carefully before starting the assembly process. These parts are cumbersome and heavy. Therefore, two people are recommended in order to prevent personal injury and insure the parts are not damaged during the assembly.

1. We recommend that you assemble this product with the assistance of the another person; this will make assembly easier, and will help to eliminate to the product of injury to persons during assembly.
2. Please do not over tighten screws or bolts until the assembly is completed.
3. Please put all parts on a non-abrasive floor before assembly, and follow the assembly steps to assemble your newly purchased product correctly and efficiently.

NO.	PART LIST	QTY
A	TABLE TOP	1 PC
B	DRAWERS	1 PC
C	LEG FRAME BACK	1 PC
D	LEG FRAME FRONT	1 PC
E	STRETCHERS	2 PCS
F	SHELF	1 PC
G	STRETCHERS SMALL	2 PCS

NO.	PART LIST	QTY
1	Bolt: Ø1/4x60	1 PC
	Flat Washer: Ø6 x 19 x 2	1 PC
	Spring Washer: Ø6 x 12 x 1	1 PC
2	Bolt: Ø1/4x40	4 PCS
	Flat Washer: Ø6 x 19 x 2	4 PCS
	Spring Washer: Ø6 x 12 x 1	4 PCS
3	Allen Key: M4	1 PC
4	Bolt: Ø1/4 x 15mm	18 PCS

**STEP 1: Assemble the leg frame front, leg frame back with 2 stretchers**

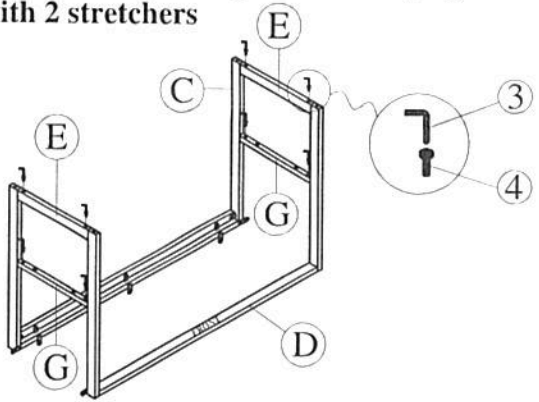

**STEP 2: Attach the legs frame to the table top.**  
**Note: Attach the leg frame front same side with the table top**

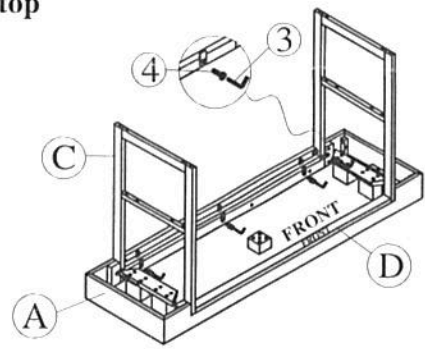

**STEP 3: Pull the drawer back and assemble the bolt.**

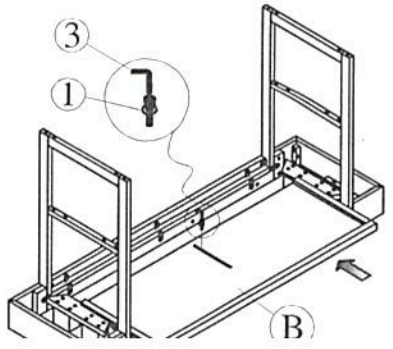

**STEP 4: Attach the shelf to the stretchers**

