



**INSTRUCTIONS D'ASSEMBLAGE**  
**ASSEMBLY INSTRUCTIONS**

---

**M**ONARCH  
SPECIALTIES INC.

# I 2701

---

**MEUBLE TV -**  
**42" L / EN COIN TAUPE FONCE ET PORTES VITRES**

**TV STAND -**  
**42" L / DARK TAUPE CORNER WITH GLASS DOORS**





**POUR DE L'ASSISTANCE OU POUR COMMANDER  
DES PIÈCES CONTACTEZ NOTRE DÉPARTEMENT  
DE SERVICE À LA CLIENTÈLE.**

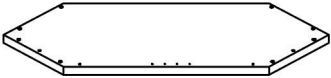

**FOR ASSISTANCE OR TO ORDER PARTS  
CONTACT OUR CUSTOMER SERVICE DEPARTMENT**

**WWW.MONARCHSERVICE.COM**

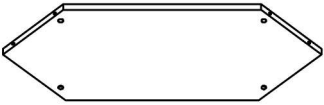
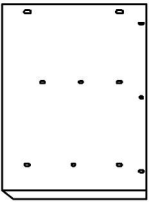
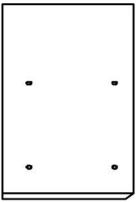

**LISTE DES PIÈCES**  
**PARTS LIST**

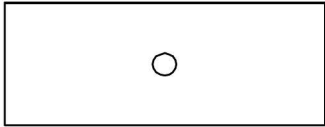
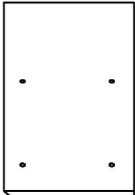
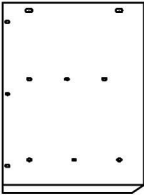
PIÈCE / PART #	IMAGE	DESCRIPTION	QTY / QTÉ
1		TOP PANEL PANNEAU DE SURFACE	1
2		SHELF ÉTAGÈRE	1
3		BOTTOM PANEL PANNEAU DU BAS	1
4		FRONT FACING LEFT LEG PATTE AVANT GAUCHE	1
5		BACK FACING LEFT LEG PATTE ARRIÈRE GAUCHE	1

**LISTE DES PIÈCES**  
**PARTS LIST**

PIÈCE / PART #	IMAGE	DESCRIPTION	QTY / QTÉ
6		<p align="center"><b>BACK PANEL</b> <b>PANNEAU ARRIÈRE</b></p>	2
7		<p align="center"><b>BACK FACING RIGHT LEG</b> <b>PATTE ARRIÈRE DROITE</b></p>	1
8		<p align="center"><b>FRONT FACING RIGHT LEG</b> <b>PATTE AVANT DROITE</b></p>	1
9		<p align="center"><b>FRONT FACING LEFT DOOR</b> <b>PORTE AVANT GAUCHE</b></p>	1
10		<p align="center"><b>FRONT FACING RIGHT DOOR</b> <b>PORTE AVANT DROITE</b></p>	1

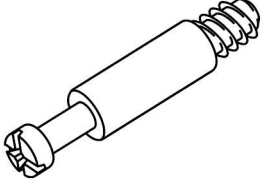
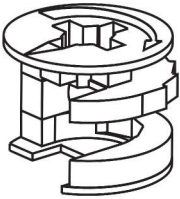
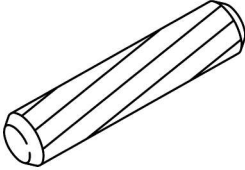
**LISTE DES PIÈCES DE MONTAGE**  
**HARDWARE LIST**

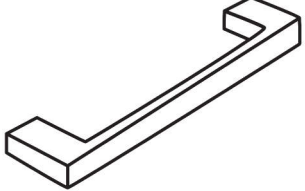
PIÈCE / PART #	IMAGE	DESCRIPTION	QTY / QTÉ
A		CAM LOCK SCREW - 1 1/8" VIS CAM LOCK - 1 1/8"	28
B		CAM LOCK CONNECTOR - Ø5/8" ÉCROU CAM LOCK - Ø5/8"	28
C		WOOD DOWEL - Ø3/8" X 1" GOUJON DE BOIS - Ø3/8" X 1"	14
D		DOOR SPRING SET ENSEMBLE DE RESSORT DE PORTE	2
E		HANDLE POIGNÉE	2

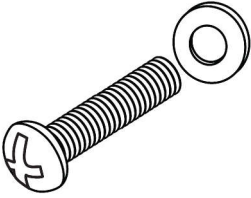
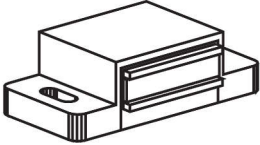
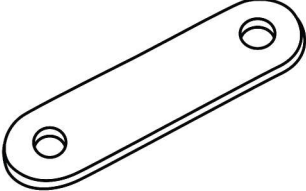
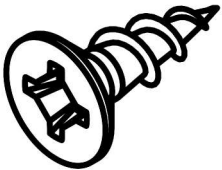
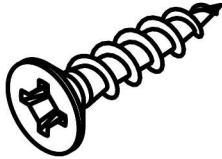

**LISTE DES PIÈCES DE MONTAGE**  
**HARDWARE LIST**

PIÈCE / PART #	IMAGE	DESCRIPTION	QTY / QTÉ
F		<p>BOLT SET ENSEMBLE DE BOULON</p>	4
G		<p>MAGNET AIMANT</p>	2
H		<p>SUPPORT PLATE PLAQUE DE SUPPORT</p>	2
I		<p>ASSEMBLING SCREW - Ø1/8" X 1/2" VIS D'ASSEMBLAGE - Ø1/8" X 1/2"</p>	4
J		<p>ASSEMBLING SCREW - Ø1/8" X 5/8" VIS D'ASSEMBLAGE - Ø1/8" X 5/8"</p>	4

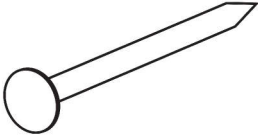
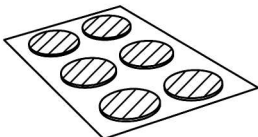
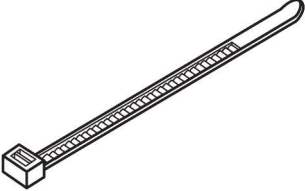
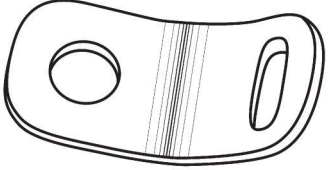
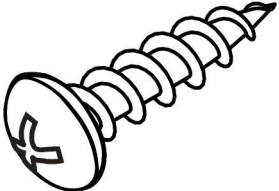
**LISTE DES PIÈCES DE MONTAGE**  
**HARDWARE LIST**

PIÈCE / PART #	IMAGE	DESCRIPTION	QTY / QTÉ
K		NAIL CLOU	24
L		FINISHING STICKER - Ø3/4" COLLANT DE FINITION - Ø3/4"	12
M		ZIP TIE - 7 3/4" X 1/8" ATTACHE AUTOBLOQUANTE - 7 3/4" X 1/8"	1
N		METAL BRACKET - 1/2" X 1/2" SUPPORT EN MÉTAL - 1/2" X 1/2"	2
O		ASSEMBLING SCREW - Ø1/8" X 1" VIS D'ASSEMBLAGE - Ø1/8" X 1"	1

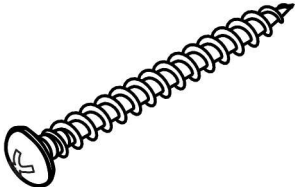
**LISTE DES PIÈCES DE MONTAGE**  
**HARDWARE LIST**

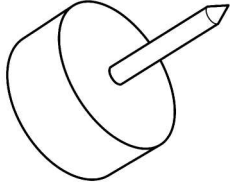
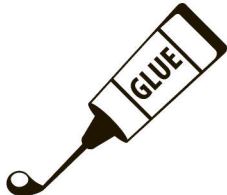
PIÈCE / PART #	IMAGE	DESCRIPTION	QTY / QTÉ
P		ASSEMBLING SCREW - Ø1/8" X 1 1/2" VIS D'ASSEMBLAGE - Ø1/8" X 1 1/2"	1
Q		ANCHOR - Ø3/8" X 1 1/2" ANCRE - Ø3/8" X 1 1/2"	1
R		FLOOR PROTECTOR - Ø5/8" PROTECTEUR DE PLANCHER - Ø5/8"	8
S		GLUE COLLE	1

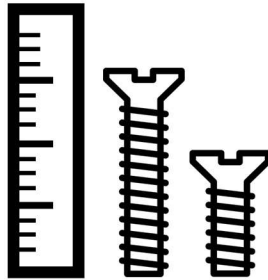

OUTIL DE VÉRIFICATION DE DIMENSIONS DES PIÈCES  
HARDWARE DIMENSIONS VERIFICATION TOOL

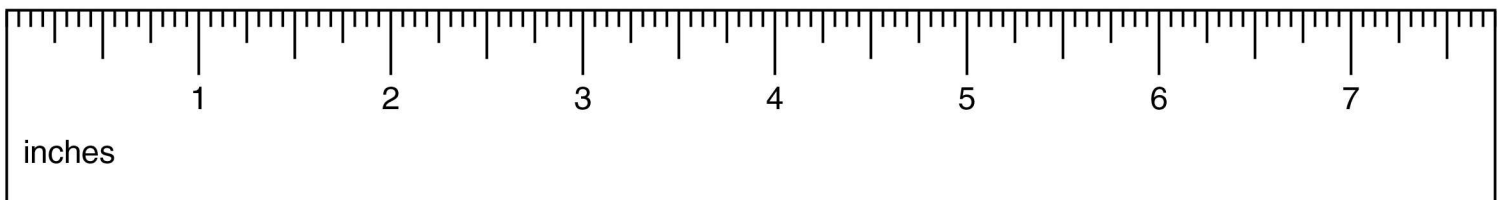



ÉTAPE / STEP 1

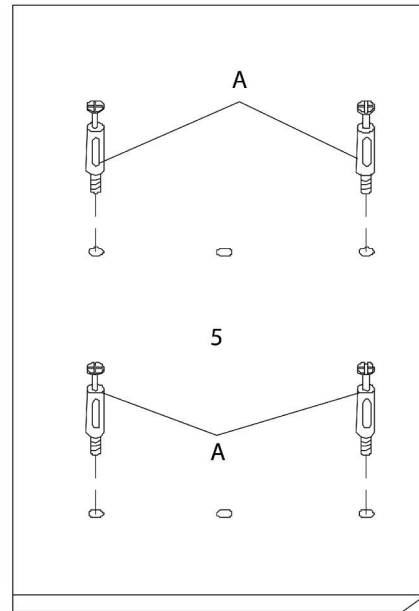
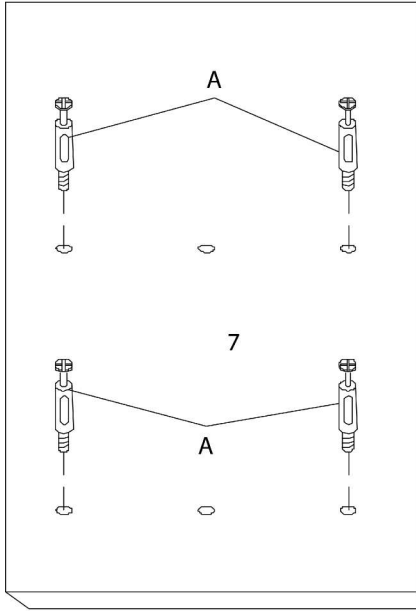

ÉTAPE / STEP 2

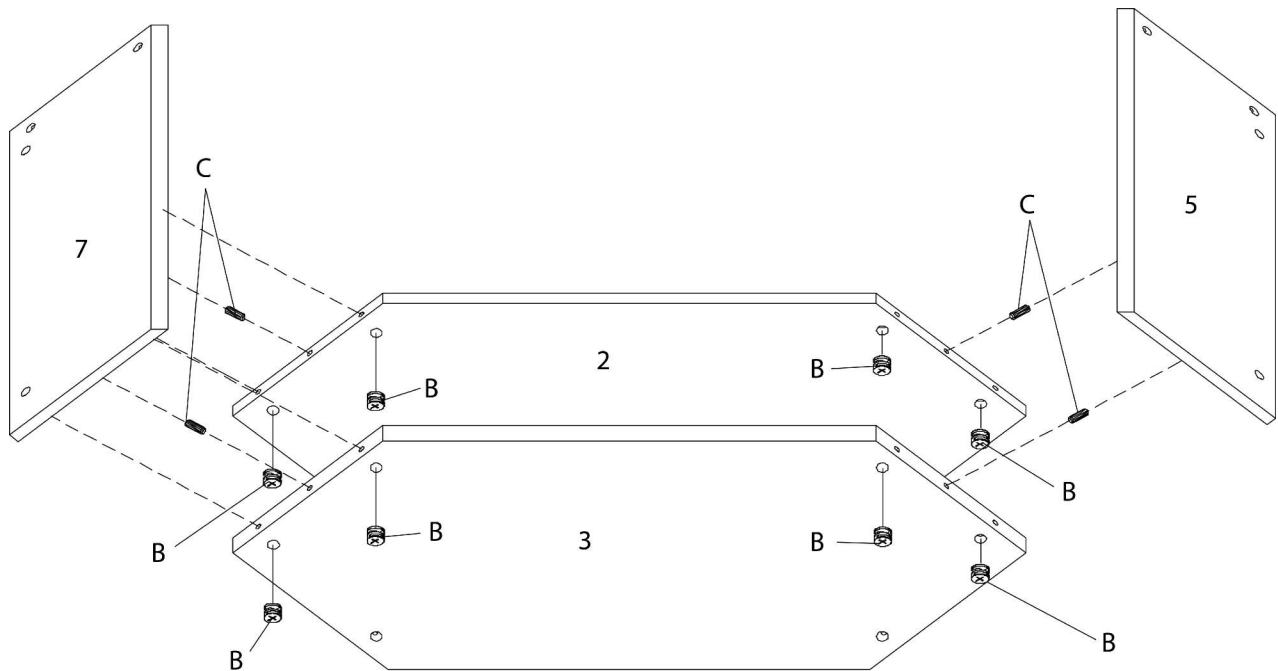

ÉTAPE / STEP 3

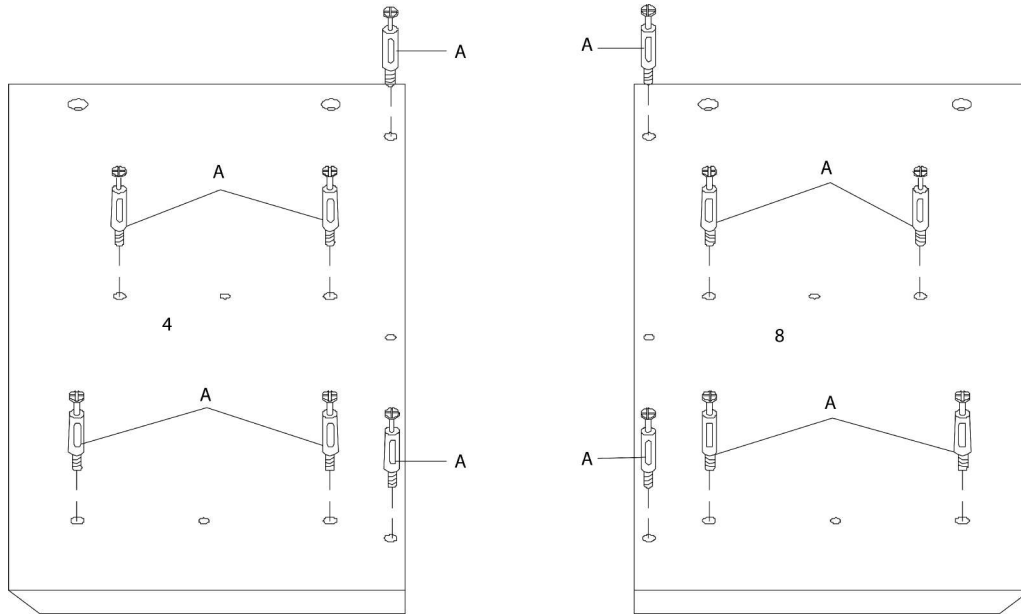

ÉTAPE / STEP 4

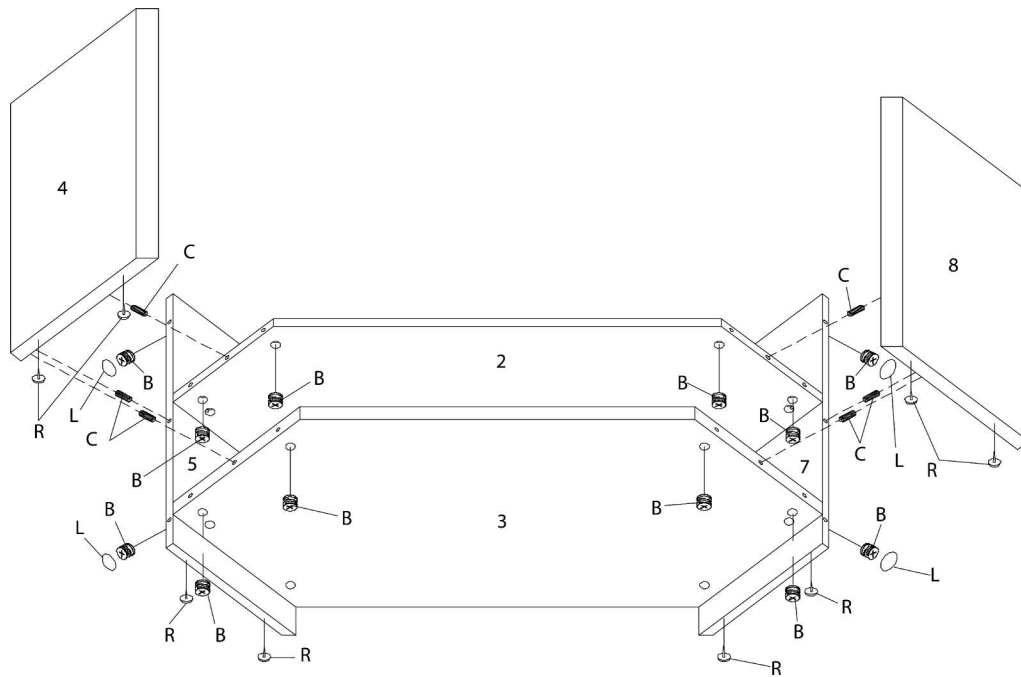

ÉTAPE / STEP 5

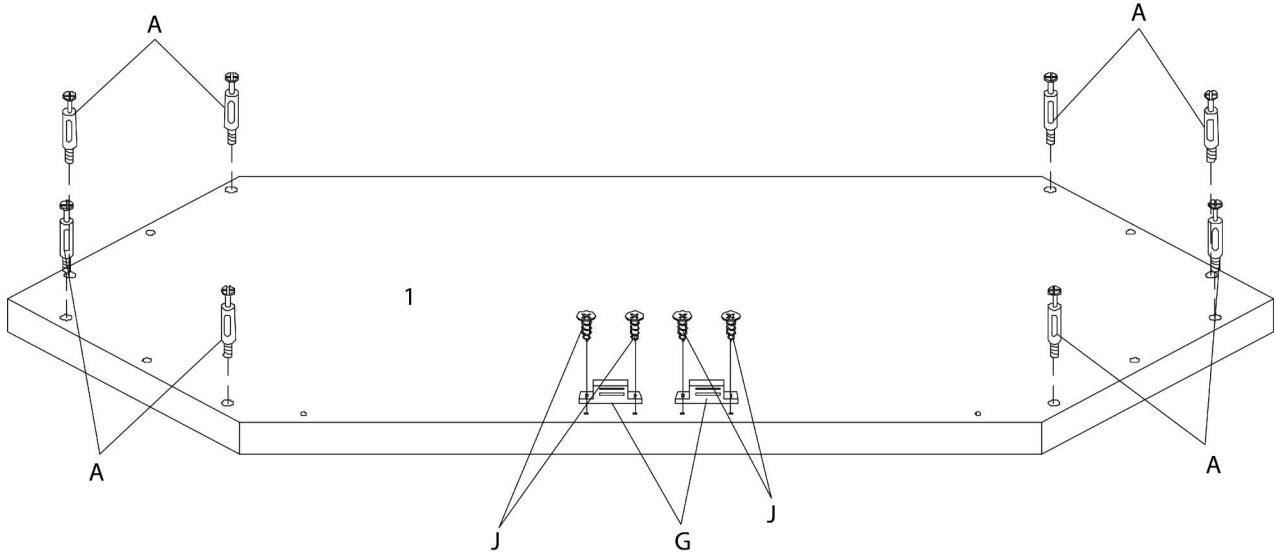

ÉTAPE / STEP 6

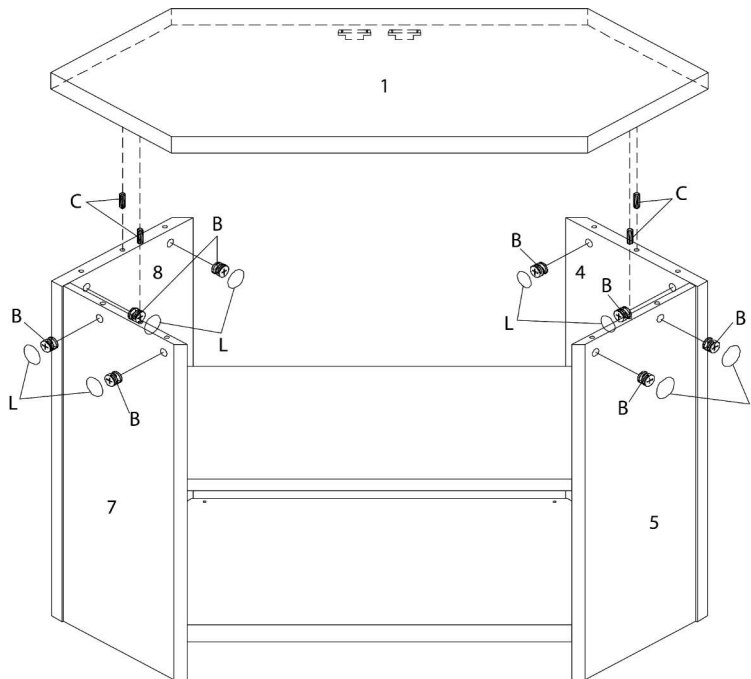

ÉTAPE / STEP 7

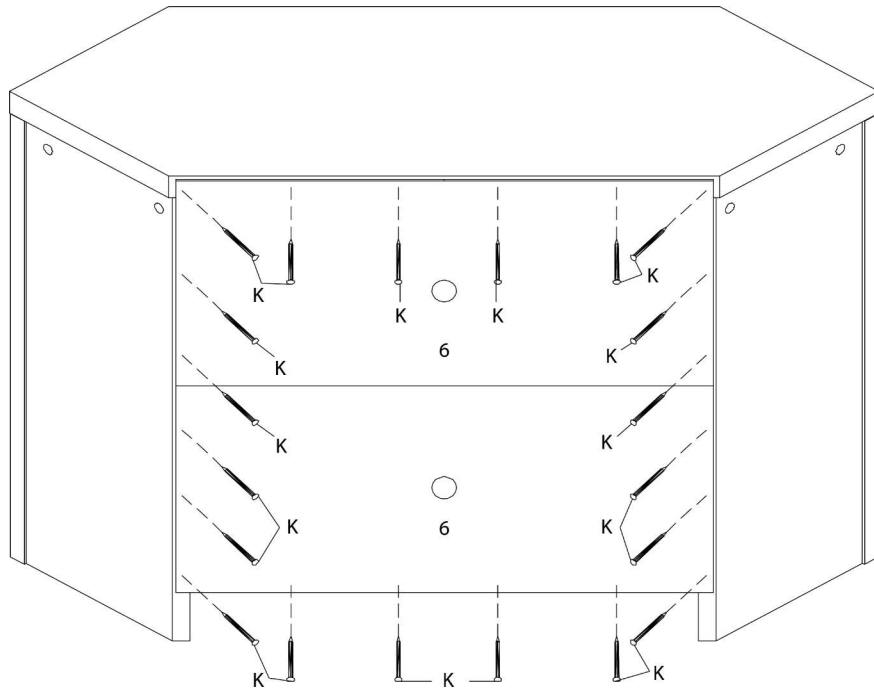

ÉTAPE / STEP 8

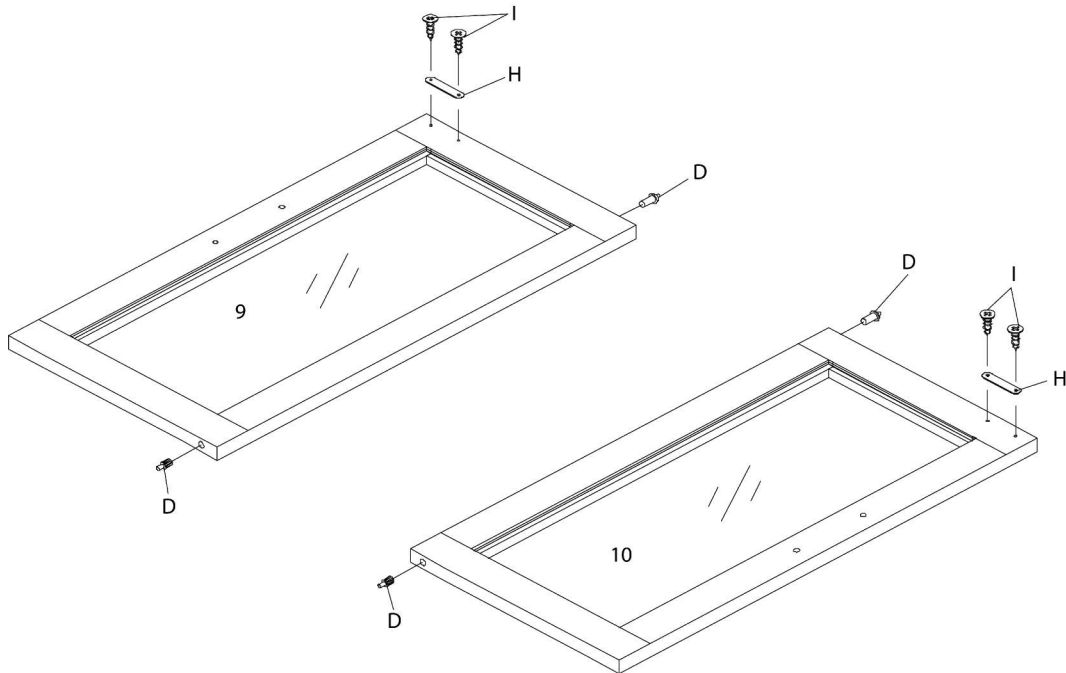

ÉTAPE / STEP 9

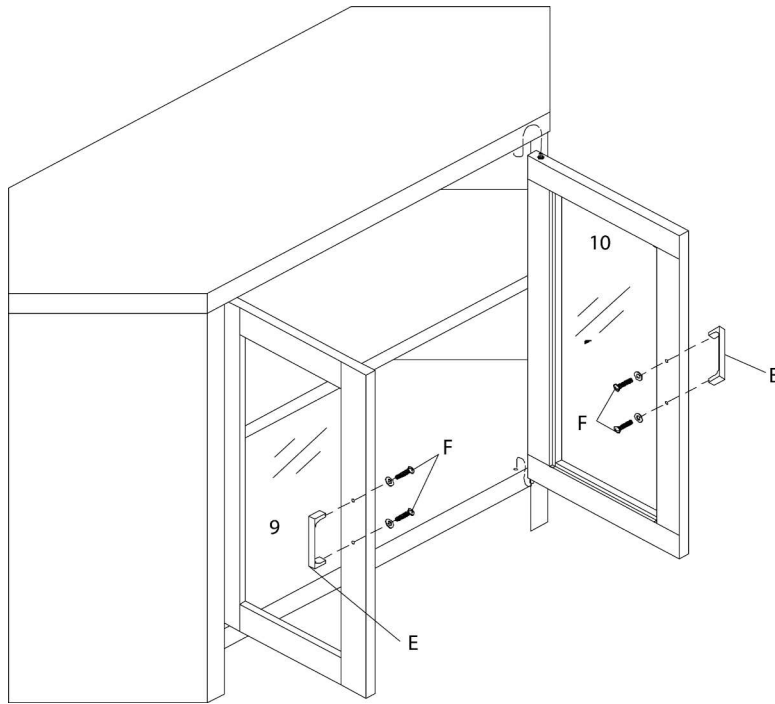

ÉTAPE / STEP 10

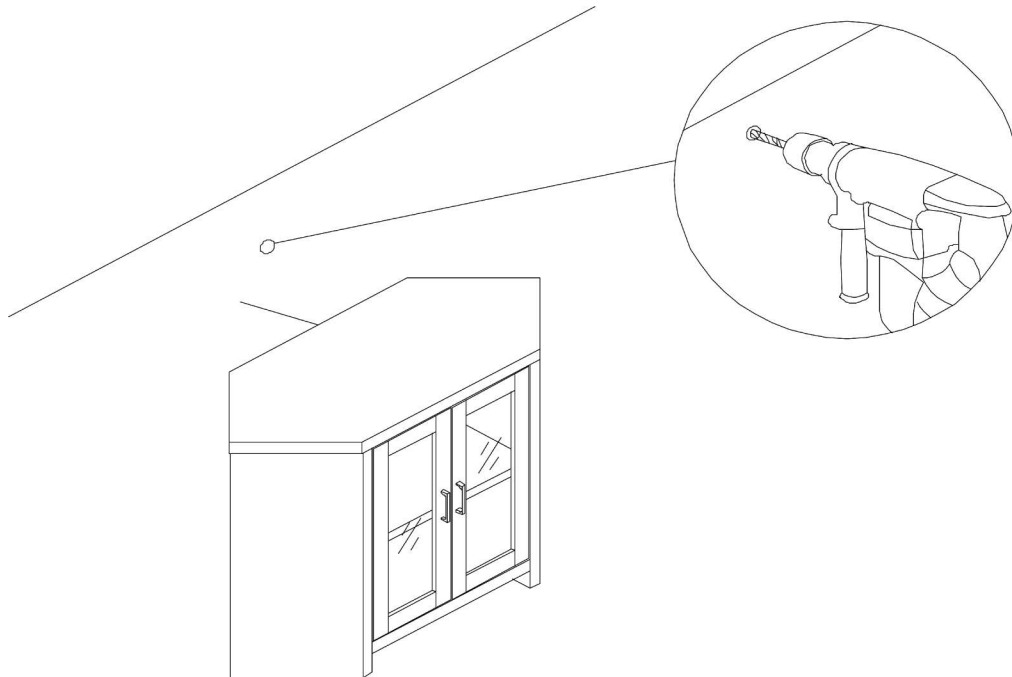

ÉTAPE / STEP 11

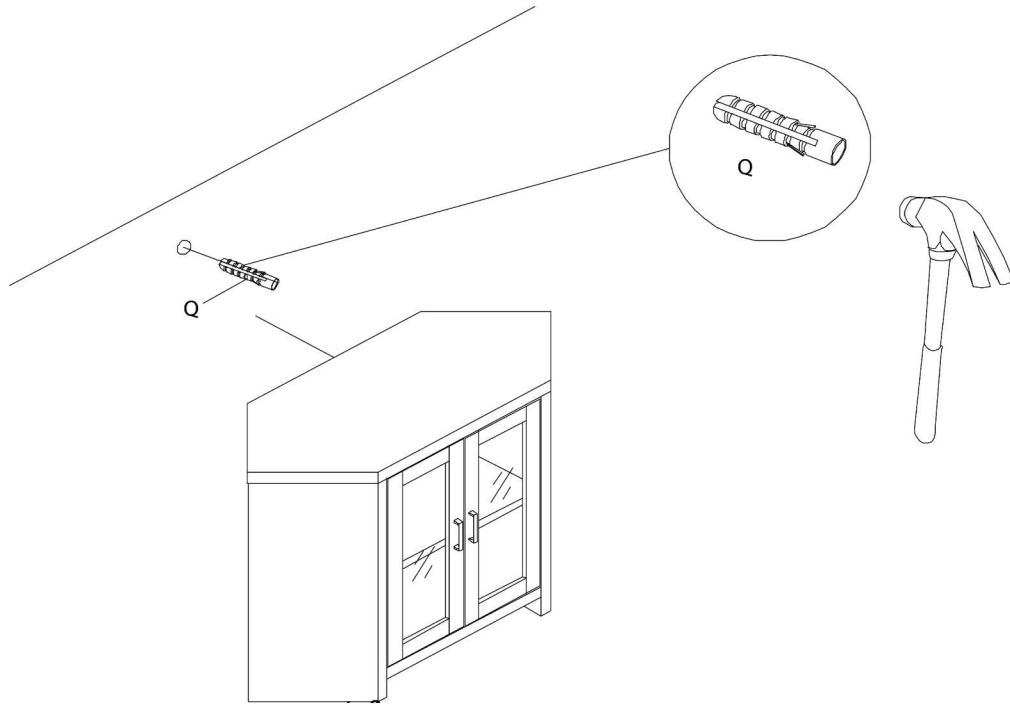

ÉTAPE / STEP 12

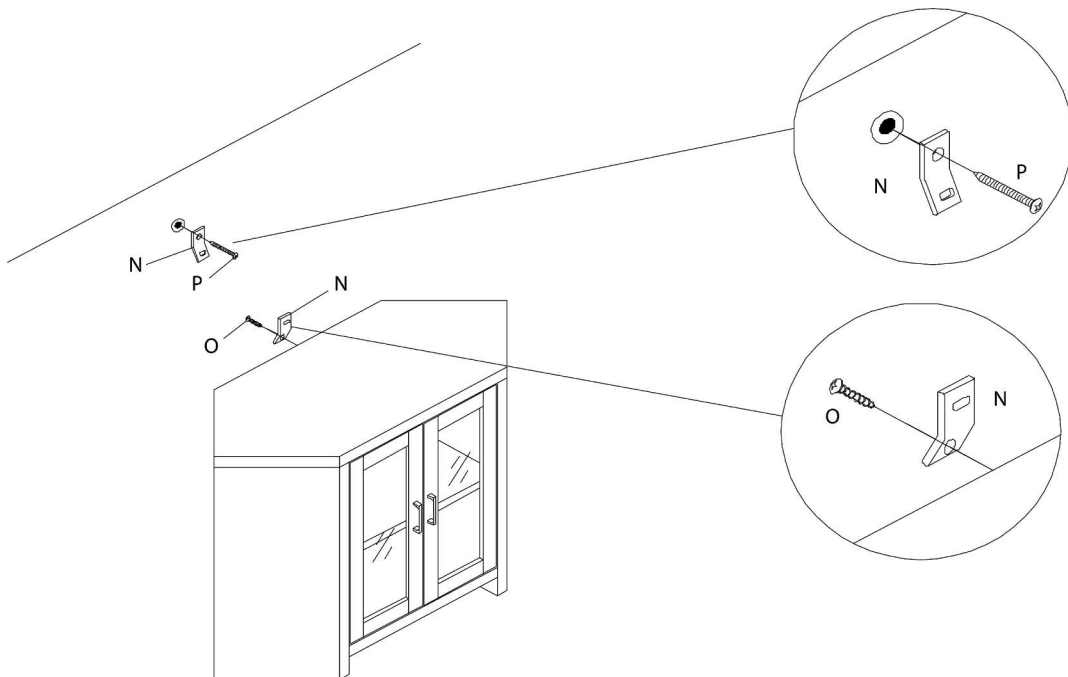

ÉTAPE / STEP 13

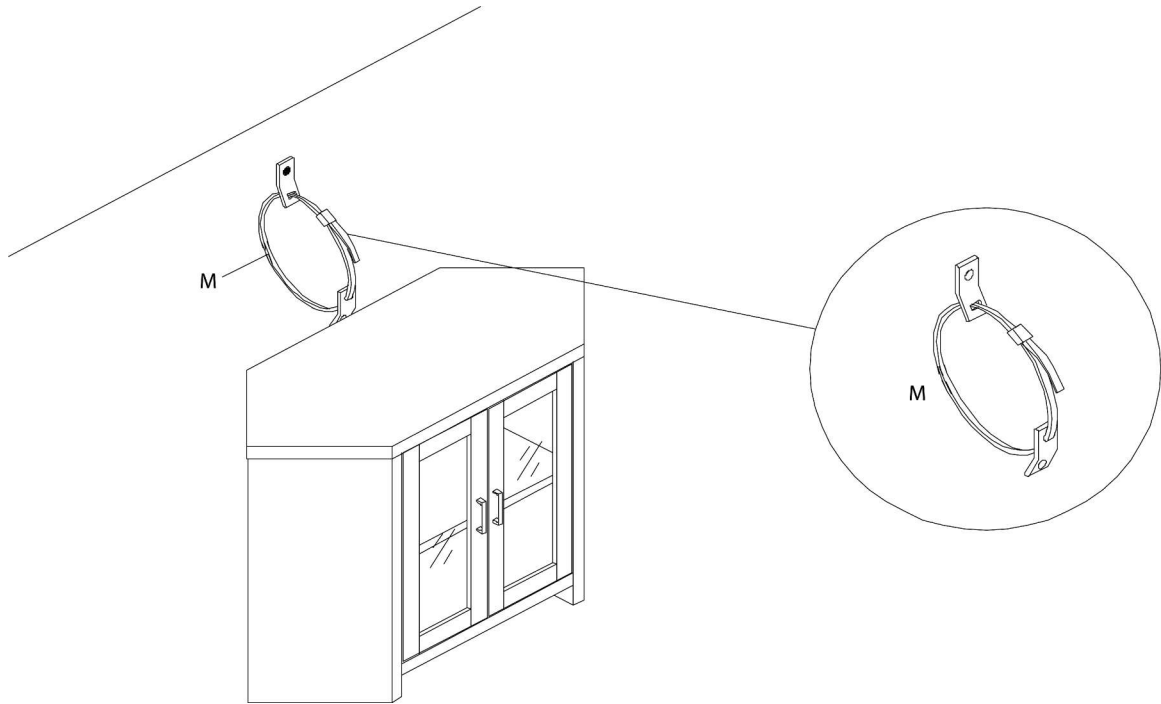

ÉTAPE / STEP 14

