





ASSEMBLY INSTRUCTIONS

FNR4825 Easton Four-Door Sideboard

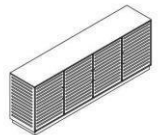

Manufactured by (CPLO) for RTG stock order

SKU#: 26008258

PARTS

SR NO.	DISCRIPTION	QTY.
A	 SIDEBOARD	1
B	 HANDLE	4

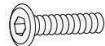
HARDWARE

SR NO.	DISCRIPTION	QTY.
C	 35X8mm	8
D	 5mm	1

STEP 1

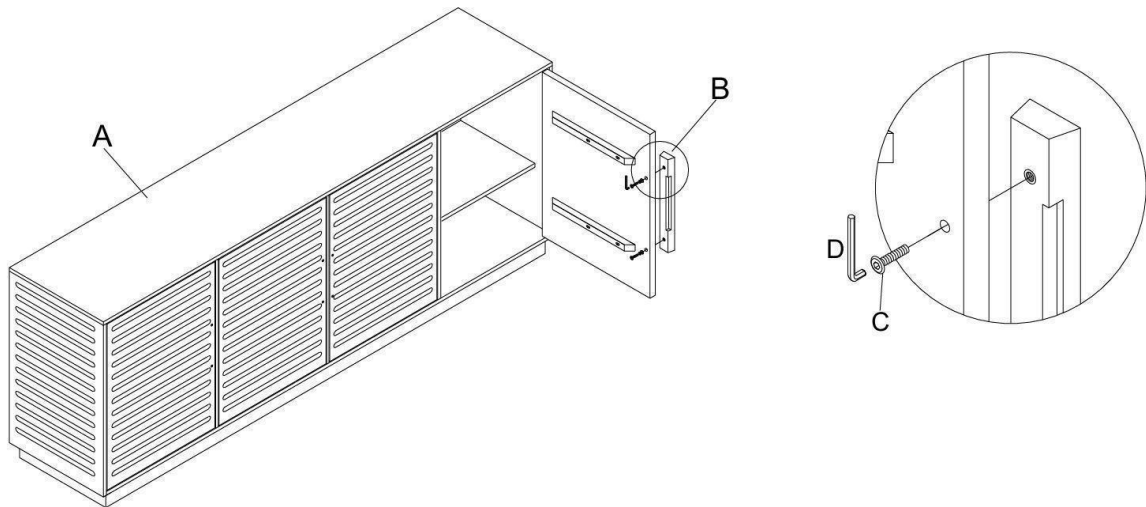

STEP 2

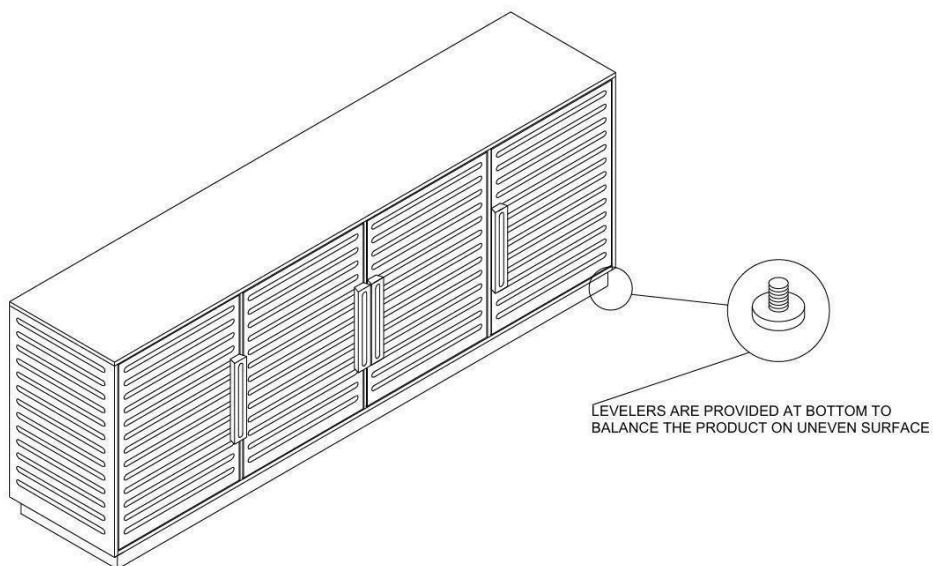



ASSEMBLY INSTRUCTIONS

FNR4825 Easton Four-Door Sideboard

Manufactured by (CPLO) for RTG stock order

SKU#: 26108250

ANTI-TIP HARDWARE



A
4x
13X13MM

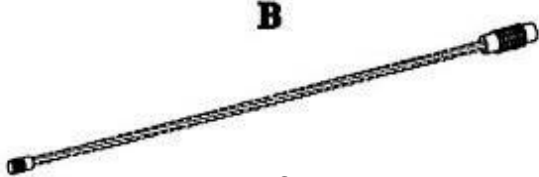

B
2x
255MM

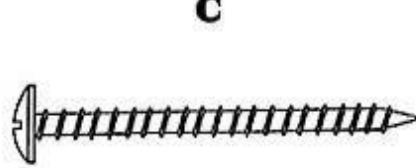

C
4x
4X40MM

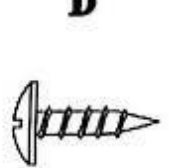

D
4x
4X19MM

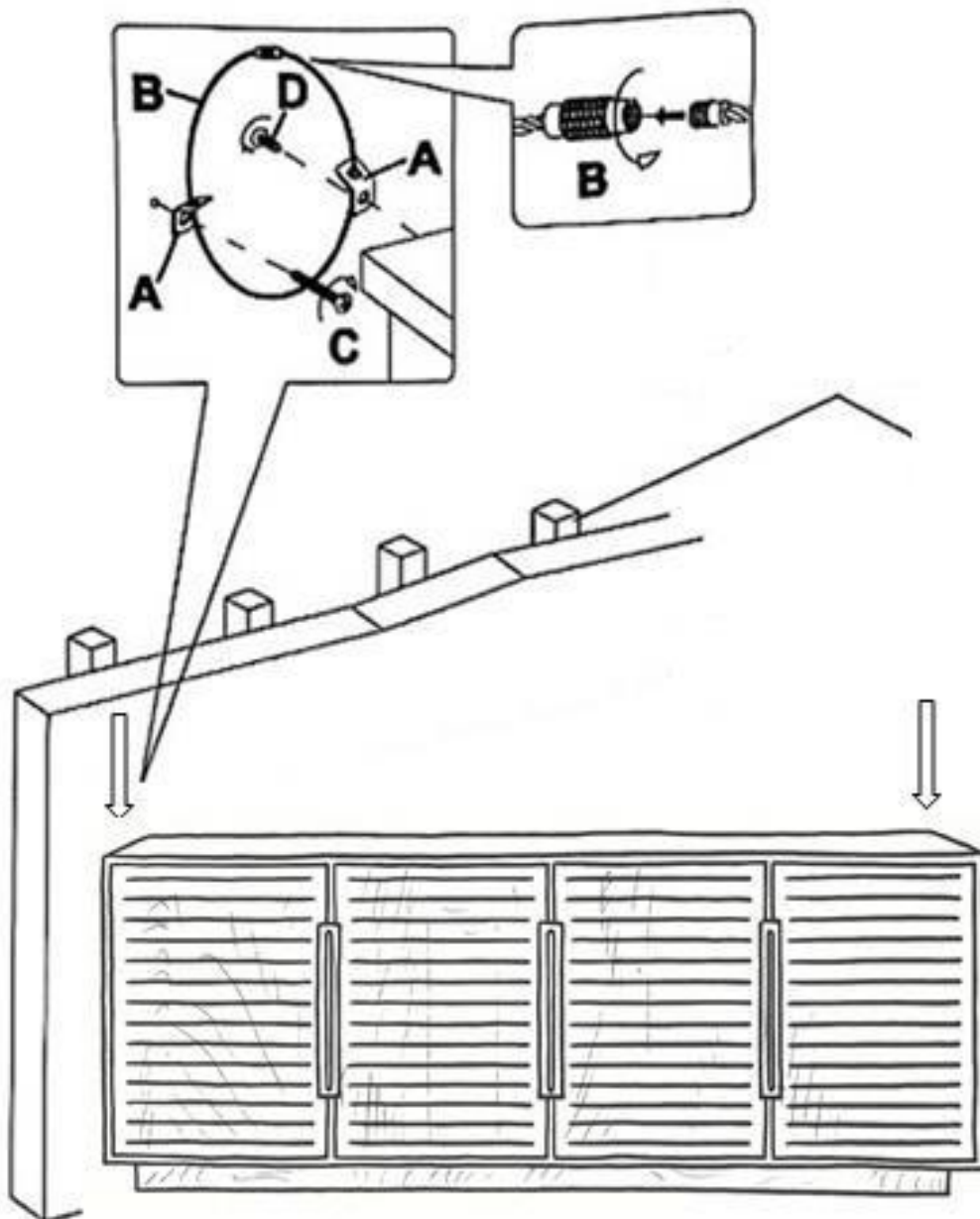

The Instruction on the bottom is:

To prevent the sideboard (F) from tipping, mount one side of the Tipping Restraint to the backside of the sideboard (F) and the other side to the wall.