

Item # : BU33SOIBC
Assembly Instructions

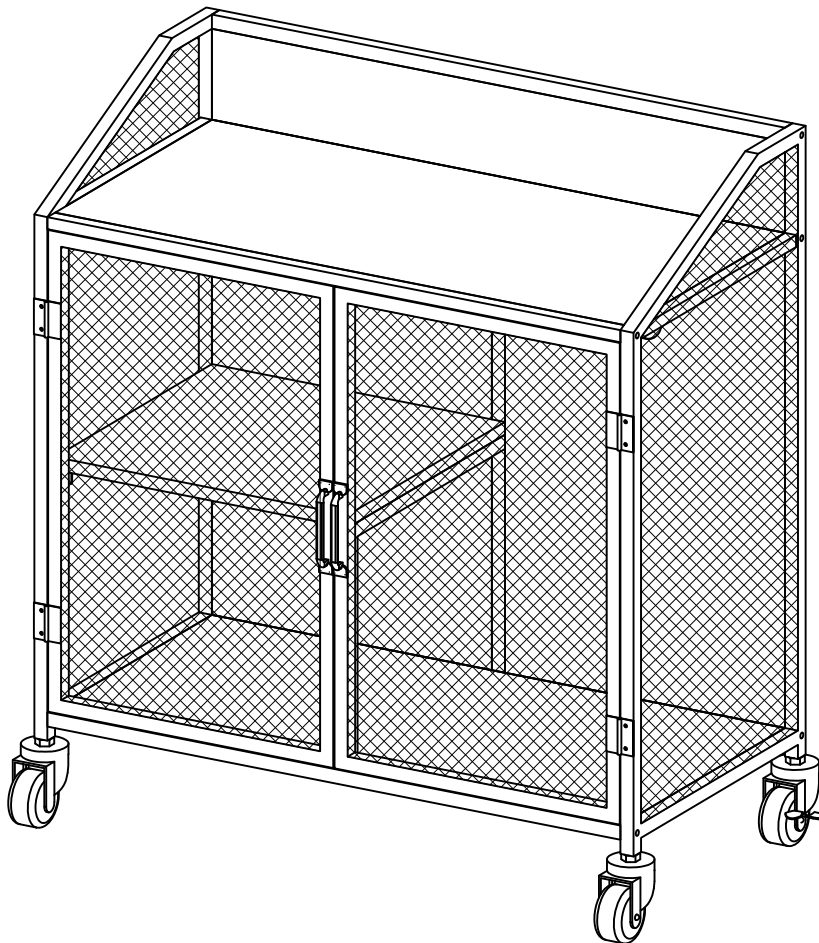

Please visit our website for the most current instructions, assembly tips, report damage, or request parts. www.walkeredison.com

Revised 04/20/2018

General Assembly Guidelines



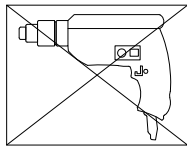



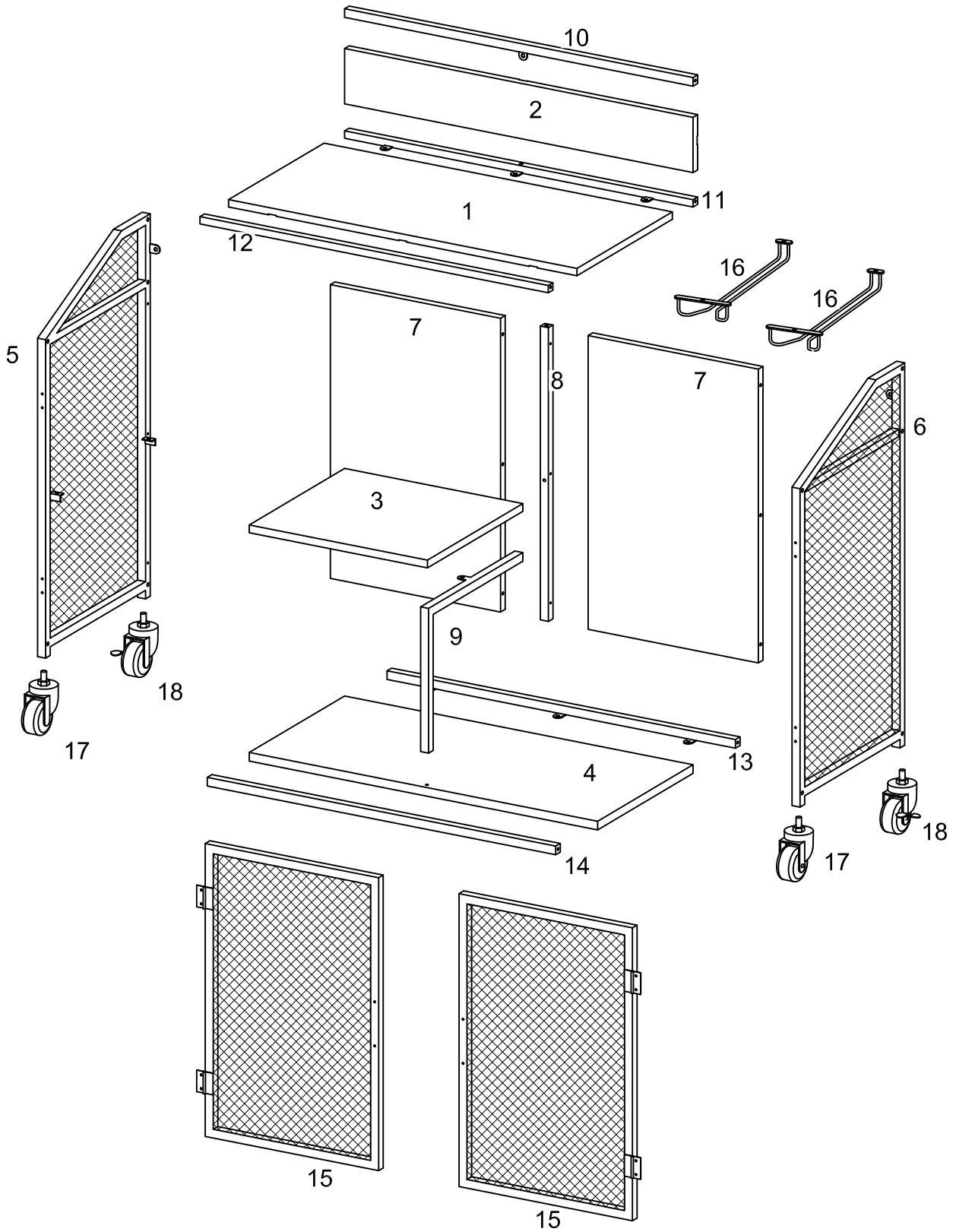

- I. Ensure that all parts and hardware are available before beginning assembly.
- II. Follow each step carefully to ensure the proper assembly of this product.
- III. Two people are recommended for ease in the assembly of this product.
- IV. The main type of hardware used to assemble this product is: bolts.
- V. Power tools should not be used to assemble this product .

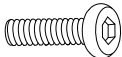

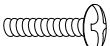
Parts List

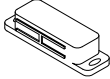

Hardware List

A		Ø1/4x12mm	Bolt	17 pcs
B		Ø1/4x25mm	Bolt	13 pcs
C		Ø4x12mm	Screw	12 pcs
D		Ø4x8mm	Screw	12 pcs
E		Ø5/32"x20mm	Bolt	4 pcs
F			Handle	2 pcs
G		M4	Hex key	1 pc
H		Ø3x16mm	Screw	4 pcs
J			Door stopper	2 pcs
K		Ø1/4"x25mm	Bolt	1 pc

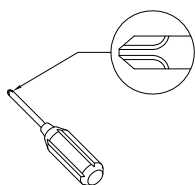

Philips head screwdriver required for assembly
(not included)

*The hardware quantities listed above are required for proper assembly.
Some extra hardware may also have been included.*

Step 1

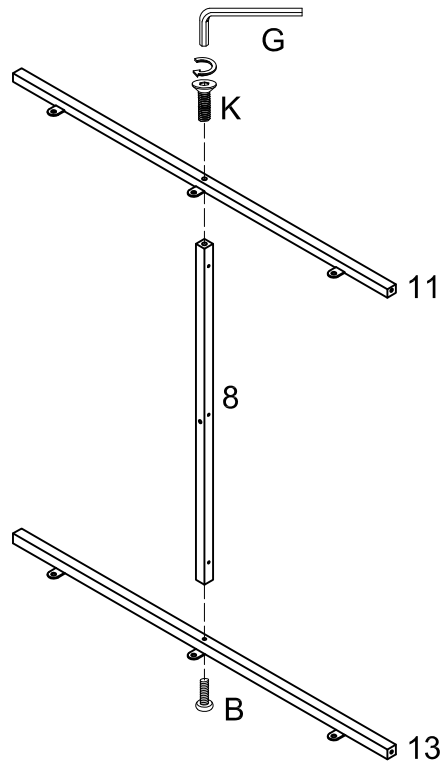

Attach part (11,13) to part (8) using bolt (B,K) with hex key (G).

Step 2

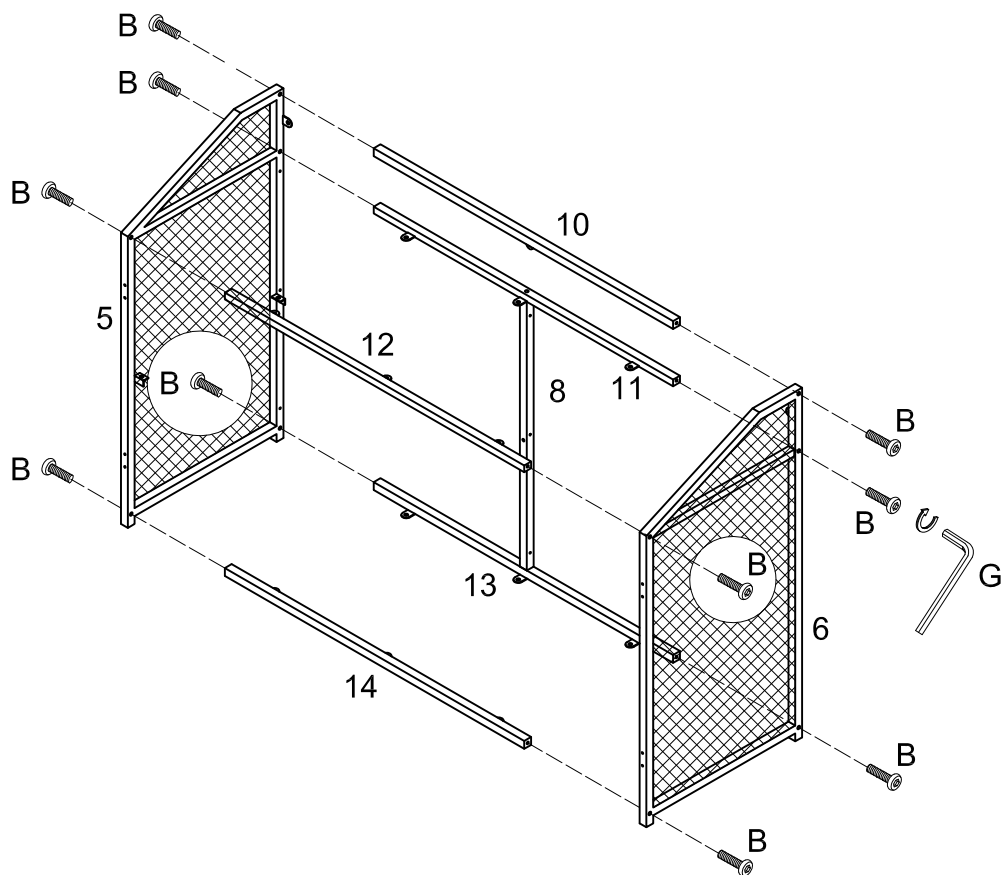

Attach part (5,6) to part (10,11,12,13,14) using bolt (B) with hex key (G).

Step 3

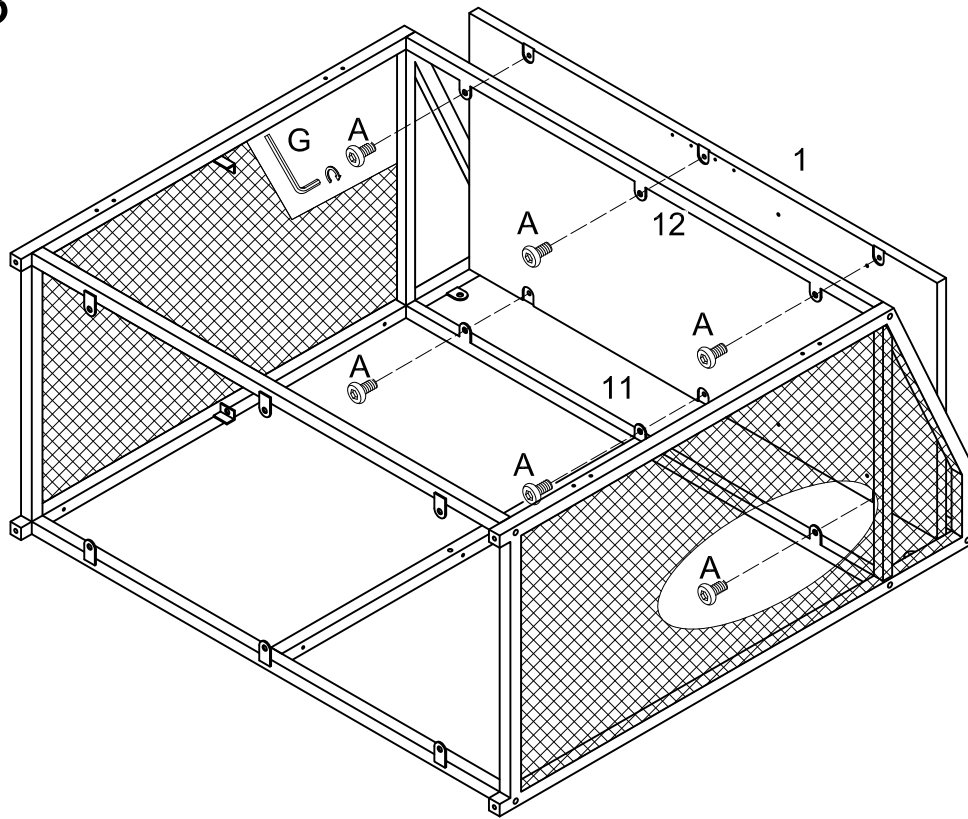

Attach part (11,12) to part (1) using bolt (A) with hex key (G).

Step 4

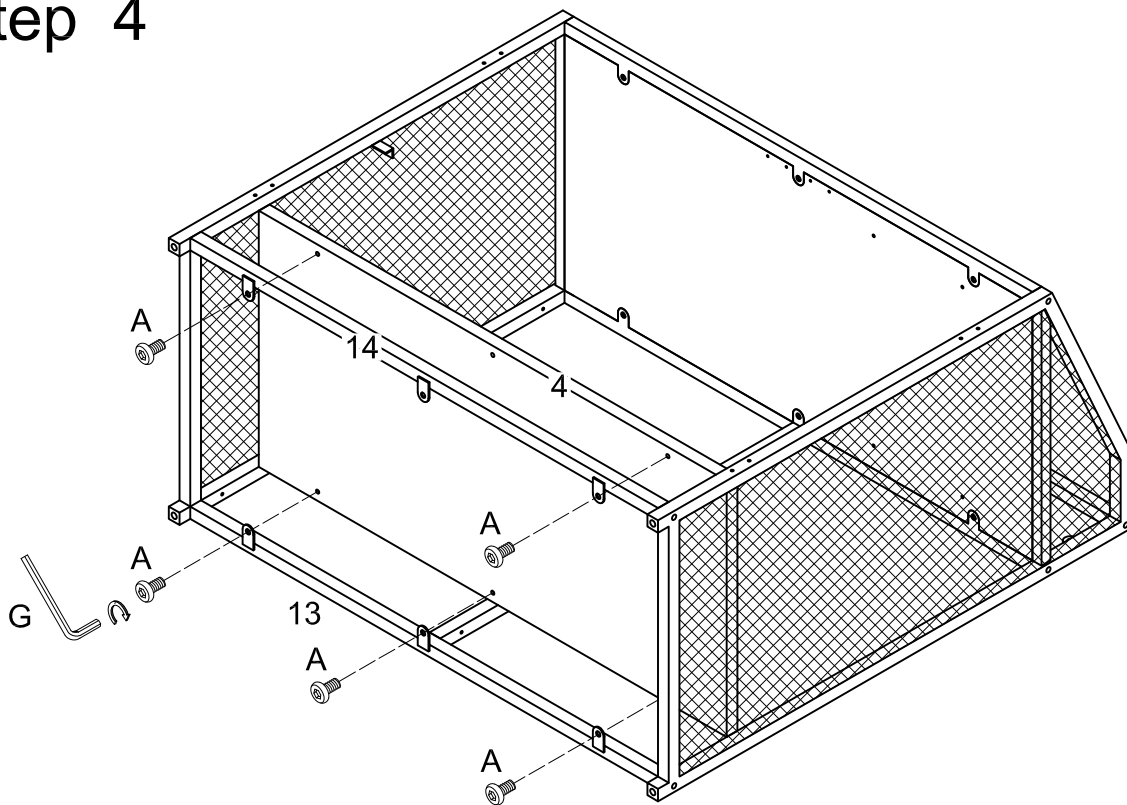

Attach part (13,14) to part (4) using bolt (A) with hex key (G).

Step 5

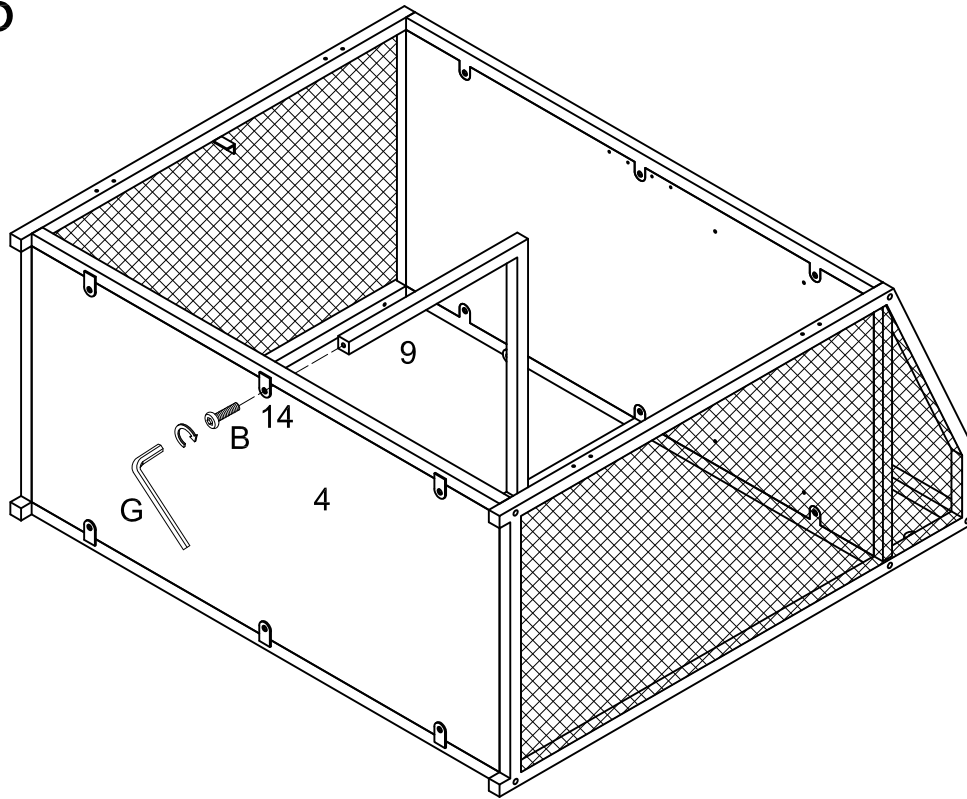

Attach part (14) to part (9) using bolt (B) with hex key (G).

Step 6

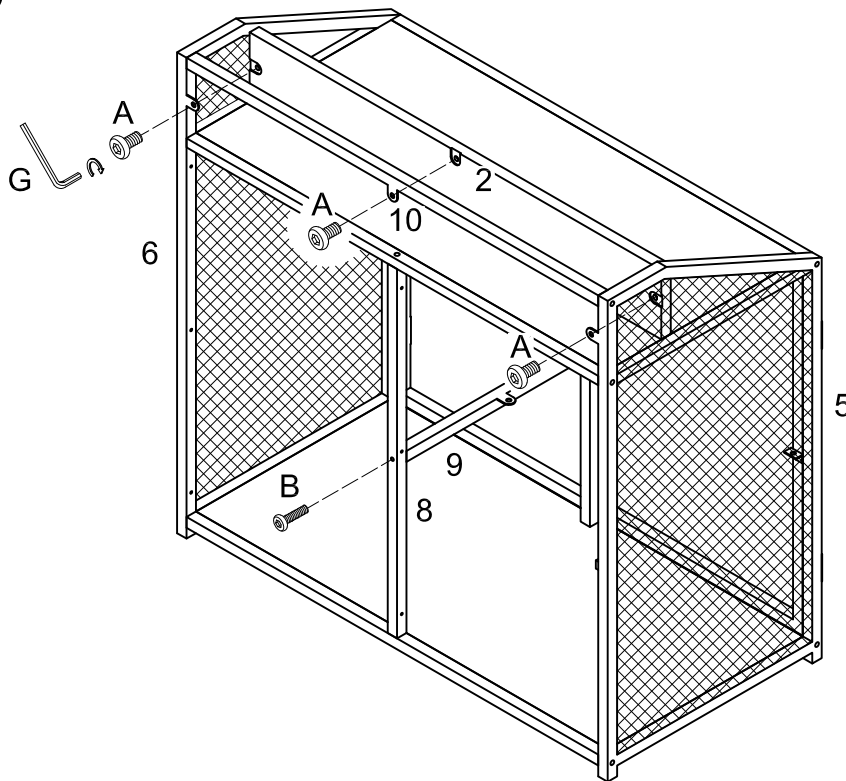

Attach part (5,6,10) to part (2) using bolt (A), and part (8) to part (9) using bolt (B) with hex key (G).

Step 7

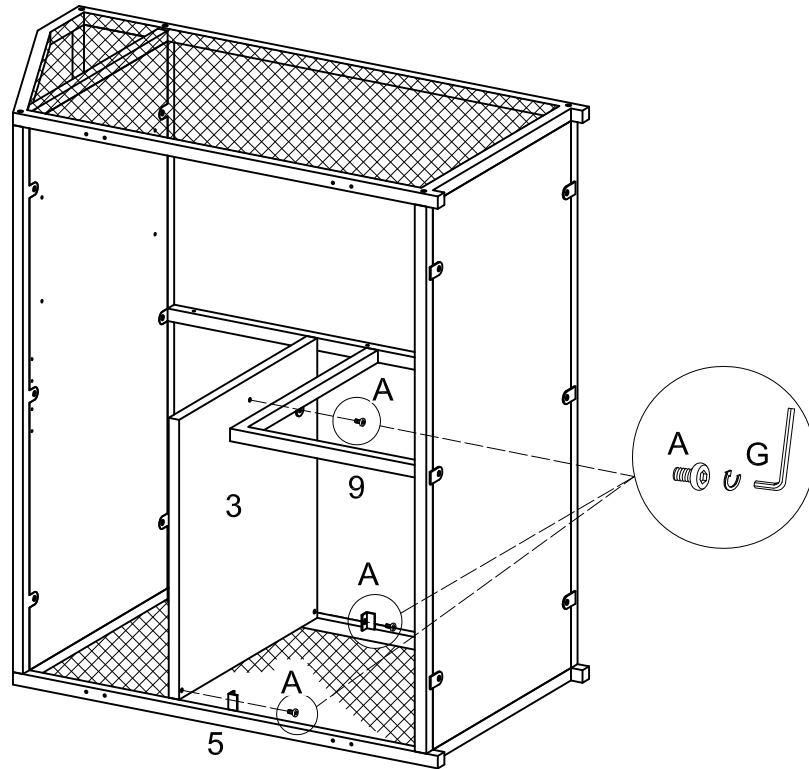

Attach part (5,9) to part (3) using bolt (A) with hex key (G).

Step 8

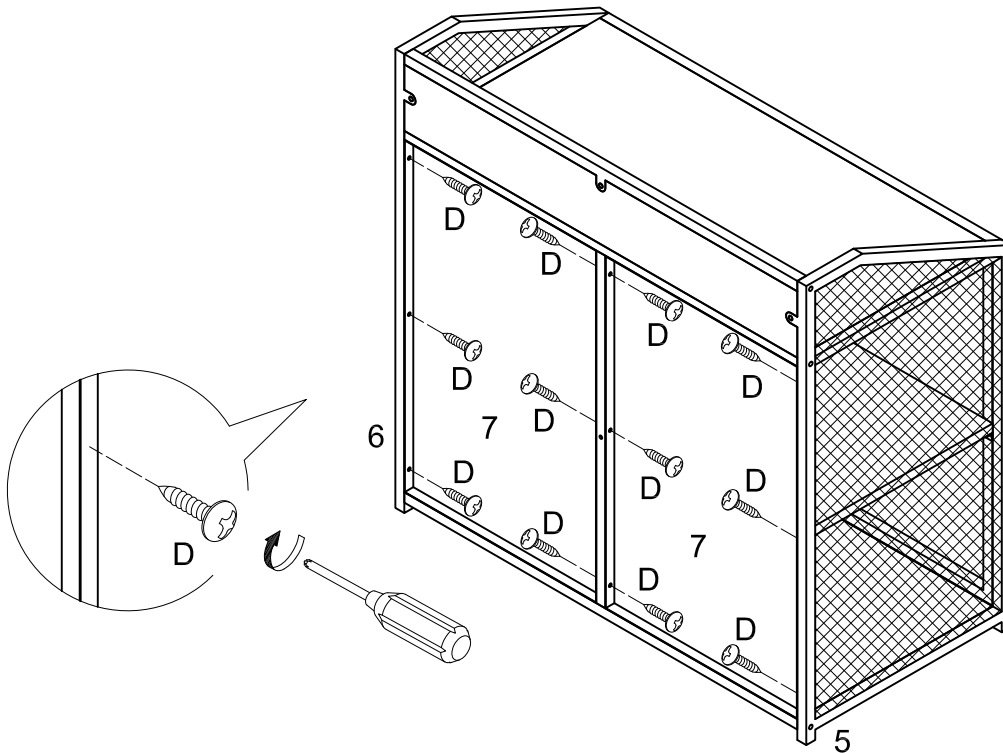

Secure part (7) to part (5, 6) using screw (D).

Step 9

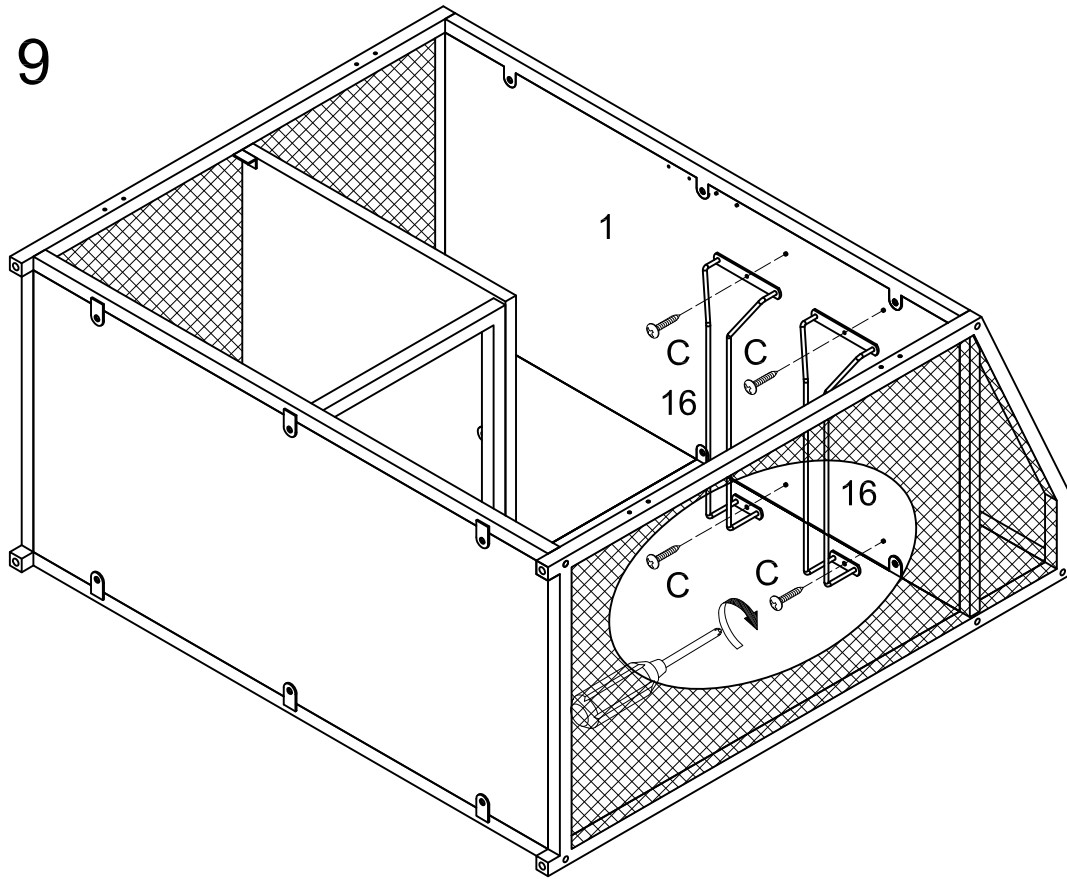

Attach part (16) to part (1) using screw (C) with screwdriver.

Step 10

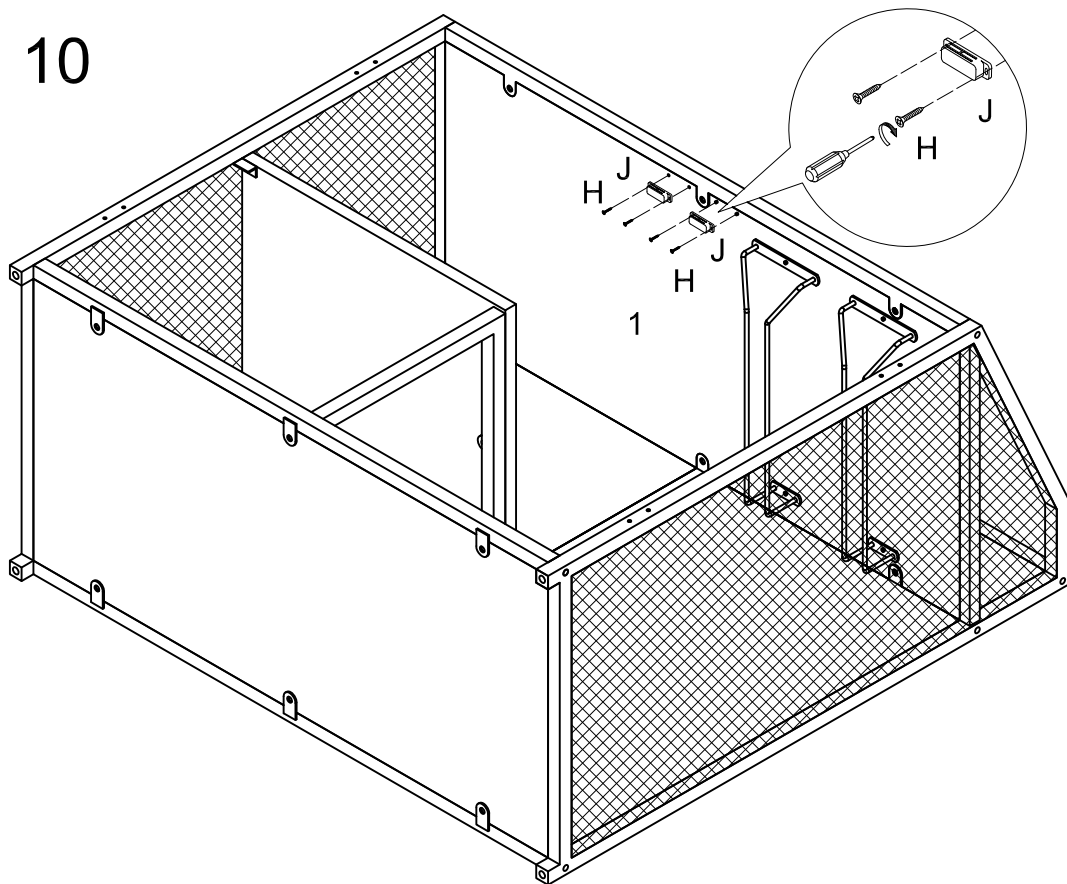

Attach door stopper (J) to part (1) using screw (H) with screwdriver.

Step 11

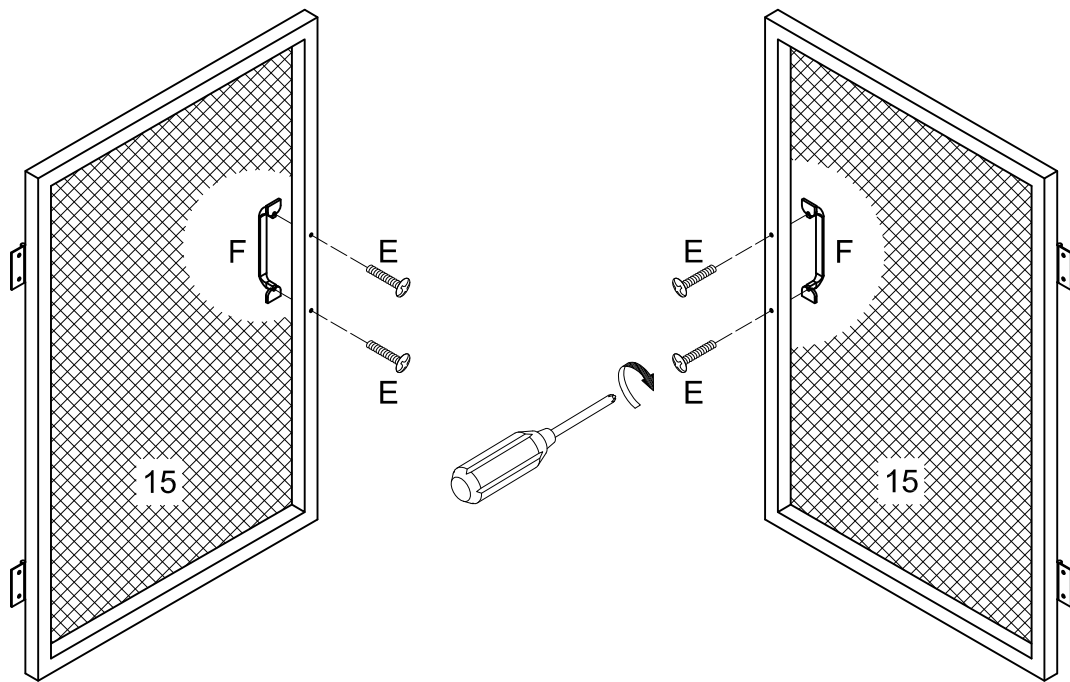

Attach handle (F) to part (15) using bolt (E) with screwdriver.

Step 12

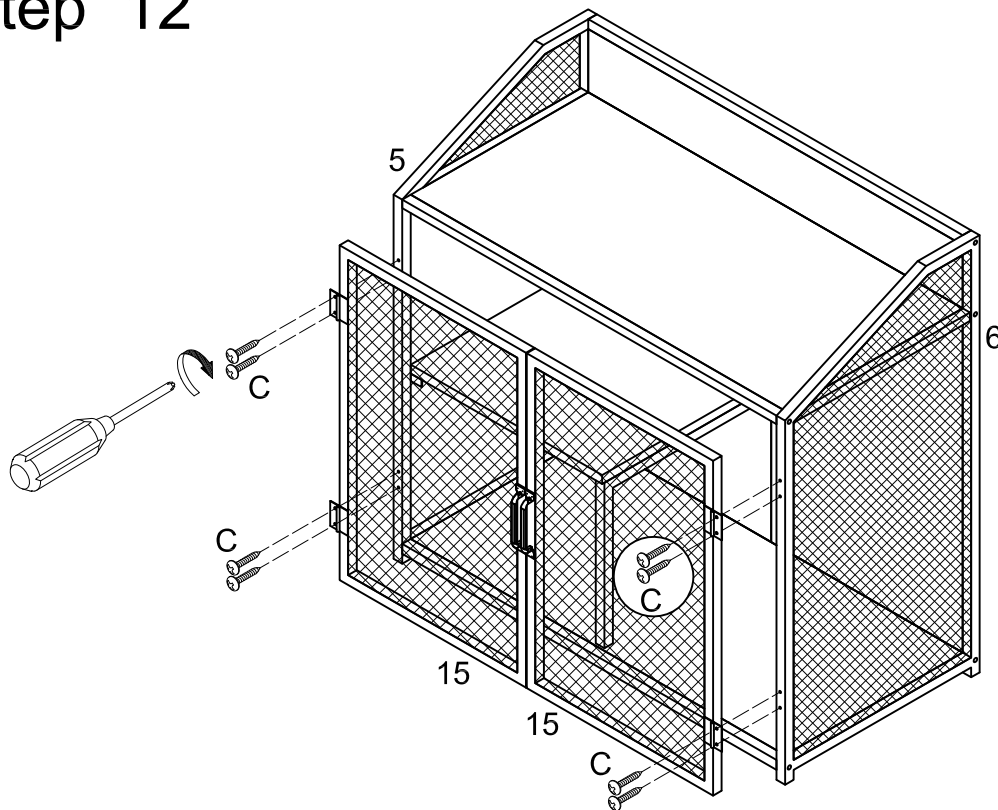

Attach part (15) to part (5,6) using screw (C) with screwdriver.

Step 13

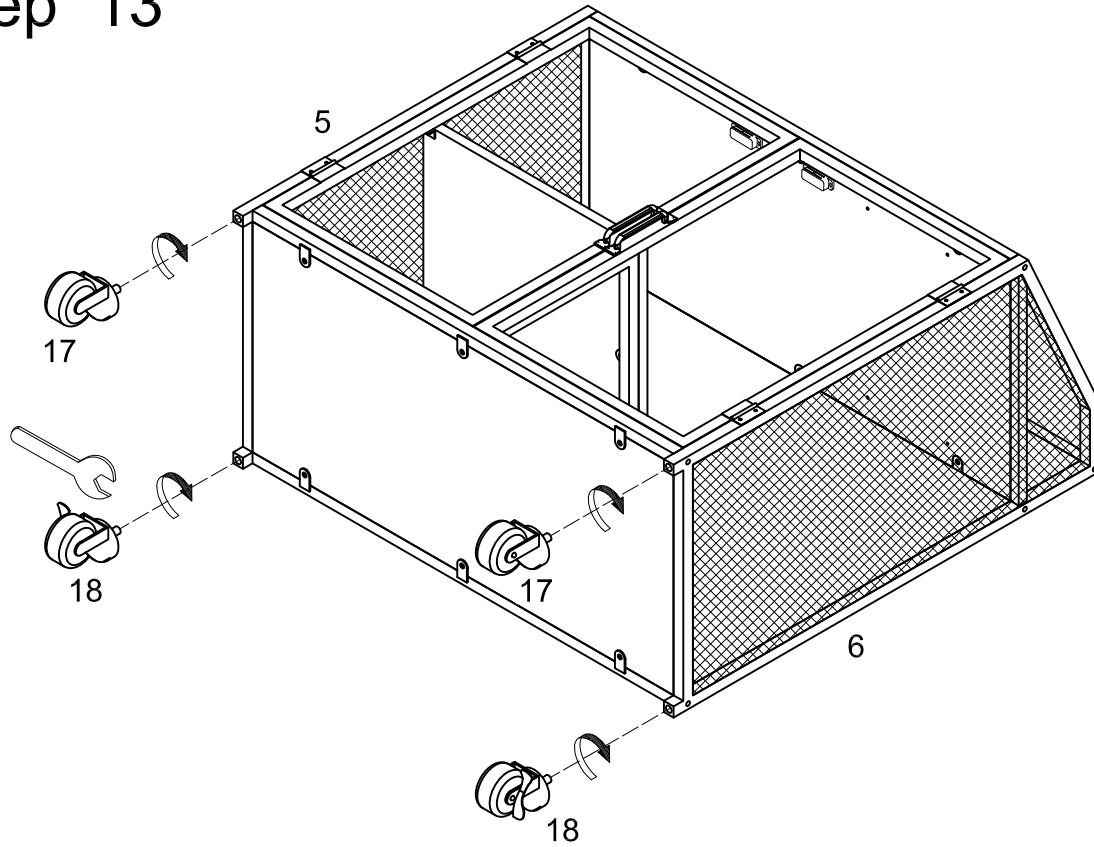

Attach part (17,18) to part (5,6) with wrench.

Step 14

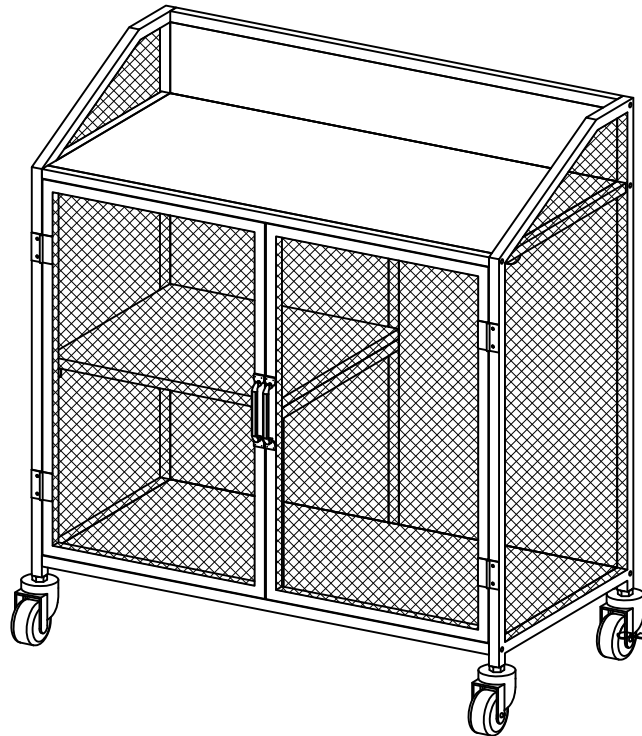

Final Assembly