

Assembly Instructions







FSLC MING 2 DOOR CREDENZA 26025052

Manufactured By: Stezan Muebles S.A.
 Tipo de vialidad: Privada
 Nombre de vialidad: Priv. 5 de Mayo
 Numero exterior: 1235

Colonia: Chipilo de Francisco Javier Mina
 Municipio: San Gregorio Atzompa
 Entidad Federativa: Puebla
 C.P.: 74325

Manufactured by FSLC for Rooms To Go

****Caution: Please read all instructions carefully before starting the assembly process. These parts are cumbersome and heavy. Therefore, two people recommended in order to prevent personal injury and ensure the parts are not damaged during the assembly.**

HARDWARE LIST				
ITEM	DESCRIPTION	IMAGE	SKU	# PZ
1	ALLEN KEY 5/32"		TOR-066	1
2	JOINT CONNECTOR ALLEN BOLT 1/4" x 2-1/2"		TOR-045	4
3	LOCK WASHER 1/4"		RON-002	4
4	WASHER 1/4"		RON-005	4
PART LIST				
A	RIGHT LEG			1
B	LEFT LEG			1

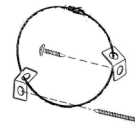
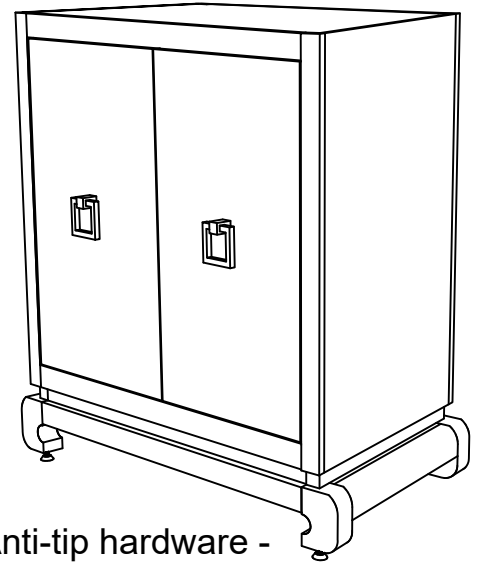

Anti-tip hardware - customer Assembly required.

INSTRUCTIONS:

1. PLACE THE TOP OF THE CONSOLE (C) UPSIDE DOWN OVER A CLEAN SURFACE.
2. PLACE THE LEGS (A) (B) IN THE HOLE OF TE BASE (C) AS SHOWN IN FIG.1.
3. PLACE THE BOLTS (2) THROUGH THE HOLES IN THE LEGS AND THE BASE AND THEN TIGHTEN STRONGLY WITH THE ALLEN WRENCH, AS SHOWN IN FIG. 2.

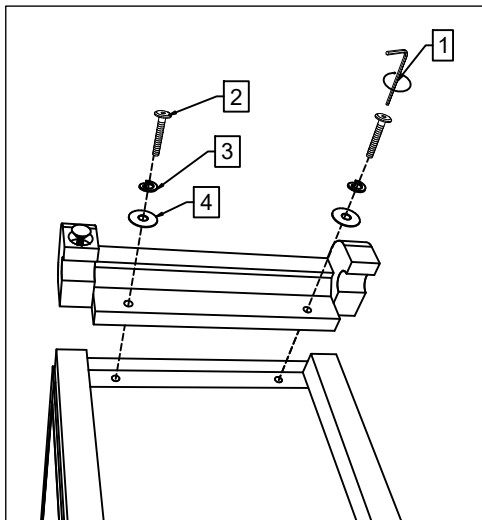

FIG. 2

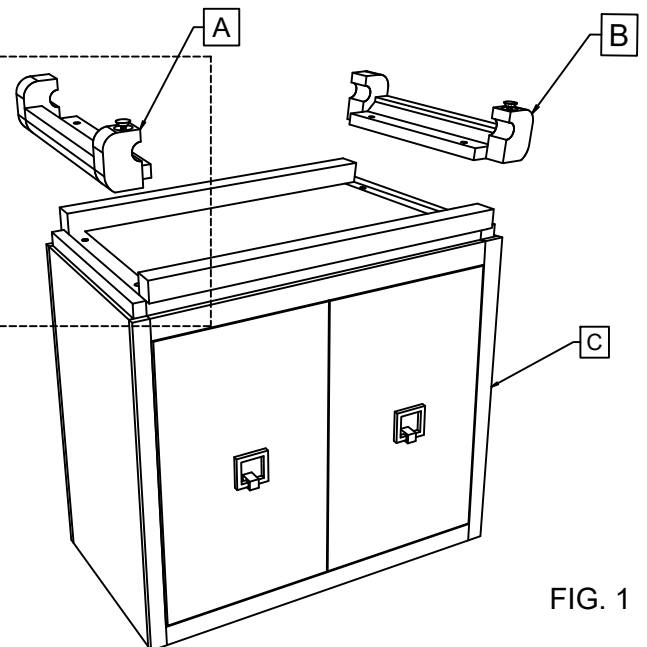

FIG. 1

Hardware Pack Location(s) : UNDERSIDE