

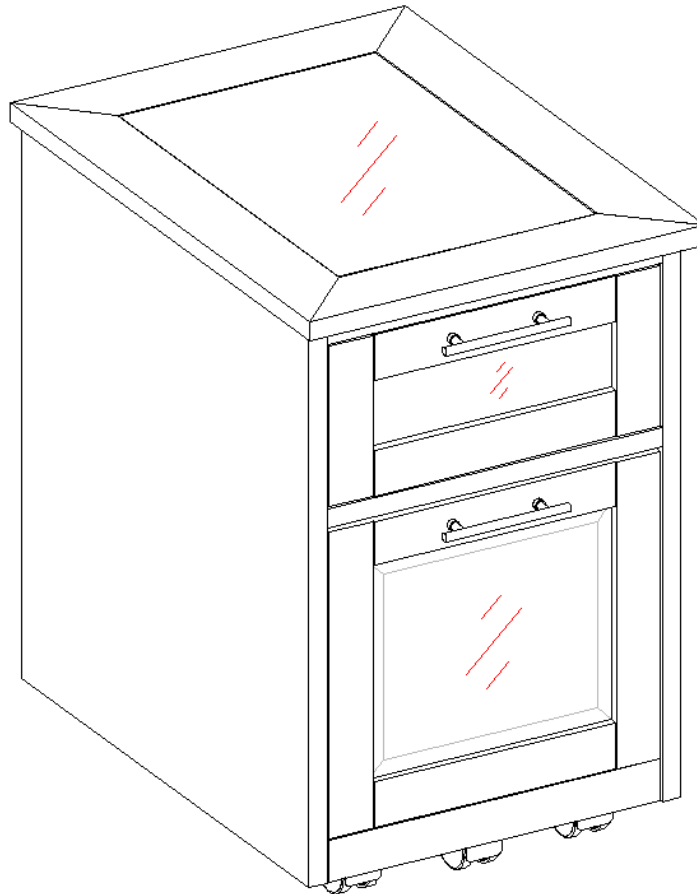

LOT NUMBER: _____
DATE PURCHASED: __/__/__

Zeta Rolling File Model # ZTRF



**ADULT ASSEMBLY REQUIRED DUE TO THE PRESENCE OF SMALL PARTS,
SHARP POINTS, SHARP EDGES AS RECEIVED**

If you have any questions regarding assembly or parts are missing, DO NOT return this item to the store where it was purchased. Please call our toll-free customer service number and have your instructions and parts list ready to provide the model name, part name or factory number:

1-866-942-5362

Pacific Standard Time: 8:30 a.m. - 4:30 p.m., Monday to Friday

Or visit our web site www.goldenoak.com

Or e-mail your request to parts@whalenfurniture.com

**THIS INSTRUCTION BOOKLET CONTAINS IMPORTANT SAFETY INFORMATION.
PLEASE READ AND KEEP FOR FUTURE REFERENCE.**

MAXIMUM RECOMMENDED WEIGHT LOADS

MANUFACTURER: Golden Oak Furniture
 CATALOG: Zeta Rolling File (ZTRF)
 DATE OF MANUFACTURE: September, 2011
 MADE IN CHINA

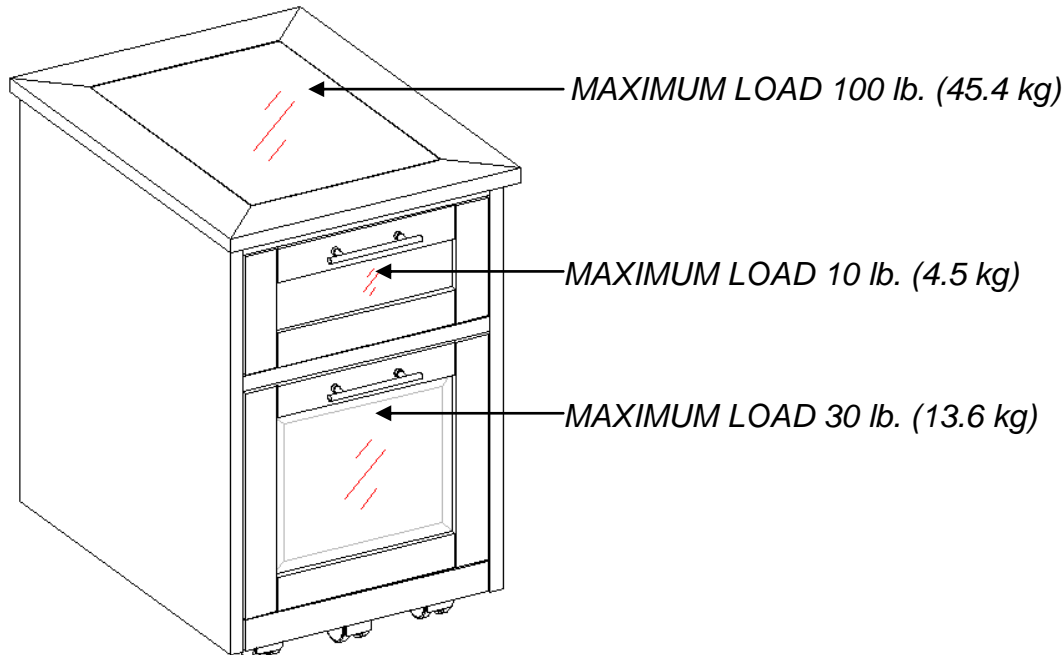

⚠ WARNING THIS UNIT IS INTENDED ONLY FOR USE WITHIN THE MAXIMUM WEIGHTS INDICATED. USE WITH PRODUCTS HEAVIER THAN THE MAXIMUM WEIGHTS INDICATED MAY RESULT IN INSTABILITY CAUSING POSSIBLE INJURY.

QUALITY GUARANTEE

We are confident that you will be delighted with your Golden Oak Furniture purchase.

Should this product be defective in workmanship or materials or fail under normal use, we will repair or replace it for up to one (1) year from date of purchase. Every Golden Oak Furniture product is designed to meet your highest expectations. We guarantee that you will immediately see the value of our fine furniture.

This warranty gives you specific legal rights and you may also have other rights which vary from province to province (state to state).

Customer Service: 1-866-942-5362

8:30 a.m. - 4:30 p.m. PST, Monday to Friday

www.goldenoak.com

Please call for replacement parts or assistance: 1-866-942-5362

Golden Oak Furniture Mfg. Inc.

Page 2

Factory # 82-14948

Parts and Hardware List

Please read completely through the instructions and verify that all parts listed are present before beginning assembly.

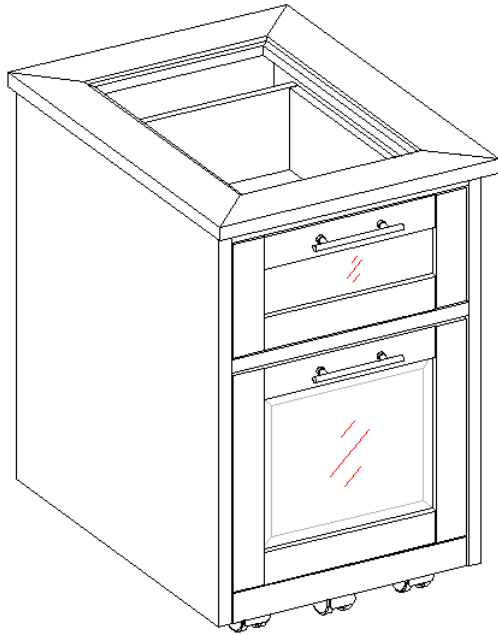

A- File Cabinet (1)

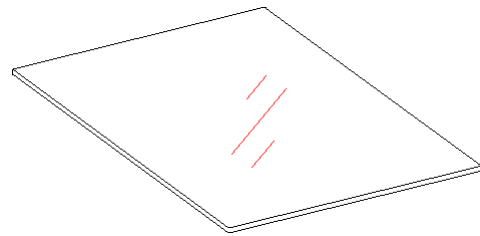

B- Top Glass (1)

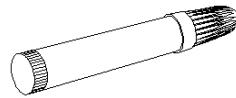

Touch-up Pen (1)

A Touch-up Pen has been provided to repair any small nicks or scratches that may occur during assembly or shipping.

DRAWER INSTALLATION

If you need to remove the drawers with ball bearing slides from the unit, please follow the steps below to prevent any damage to the slides or the drawers.

1. If you need to remove the drawer, please pull the drawer all the way out, then push the plastic release lever of the ball bearing slide up on one side and down on the other side, and then pull the drawer completely out. See detail #A.

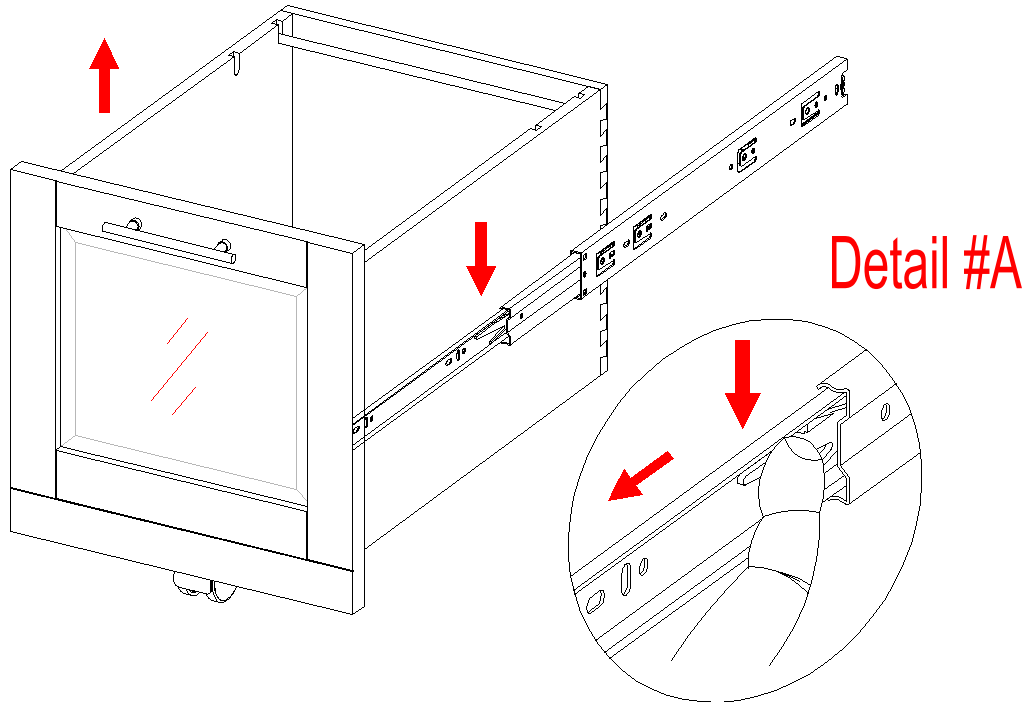

2. To place the drawer back, simply push the ball bearing cart all the way to the end of the slide (in both sides), and align the slides runner on the drawer with the slides track on the unit and push it carefully inside until it stops. See detail #B.

Note: If they do not go smoothly, please take out and repeat step.

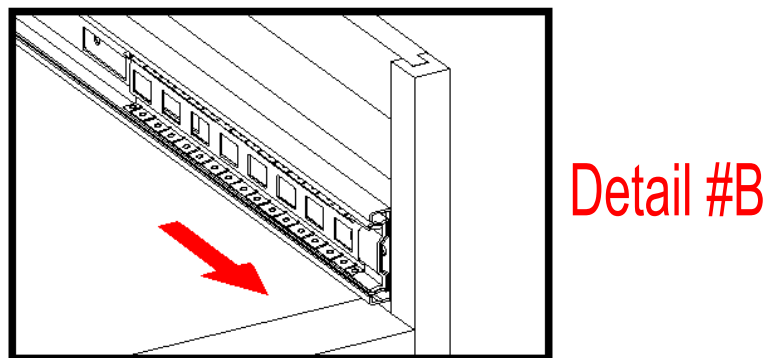

Assembly Instructions

1. Unpack the unit and confirm you have all the hardware and parts required.
2. Position Top Glass (B) with the black side of glass down onto the top groove of File Cabinet (A).

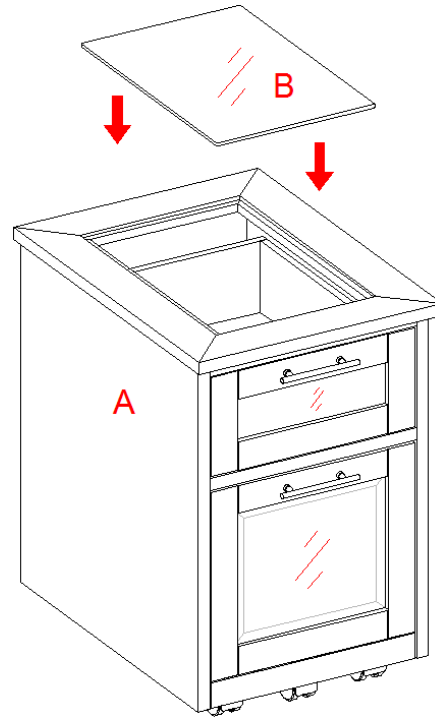

Care and Maintenance

- Use a soft, clean cloth that will not scratch the surface when dusting.
- Use of furniture polish is not necessary. Should you choose to use polish, test first in an inconspicuous area.
- Using solvents of any kind on your furniture may damage your furniture's finish.
- Never use water to clean your furniture as it may cause damage to the finish.
- Always use coasters under beverage glasses and flowerpots.
- Liquid spills should be removed immediately. Using a soft clean cloth, blot the spill gently. Avoid rubbing.
- Always use protective pads under hot dishes and plates. Heat can cause chemical changes that may create spotting within the furniture finish.
- Stains or marks from crayons or ink markers will be difficult to remove.
- In the event that your furniture is stained or otherwise damaged during use, we recommend that you call a professional to repair your furniture.

Further advice about wood furniture care

It is best to keep your furniture in a climate-controlled environment. Extreme temperature and humidity changes can cause fading, warping, shrinking and splitting of wood. It is advised to keep furniture away from direct sunlight as sun may damage the finish. Proper care and cleaning at home will extend the life of your purchase. Follow the important and helpful tips that will enhance your furniture as it ages.

We hope you enjoy your purchase for many years.

**Your assembly should now be complete.
Thank you for your purchase.**

Please call for replacement parts or assistance: 1-866-942-5362

IF YOU NEED TO ORDER PARTS PLEASE USE THE LIST BELOW
Zeta Rolling File (ZTRF)

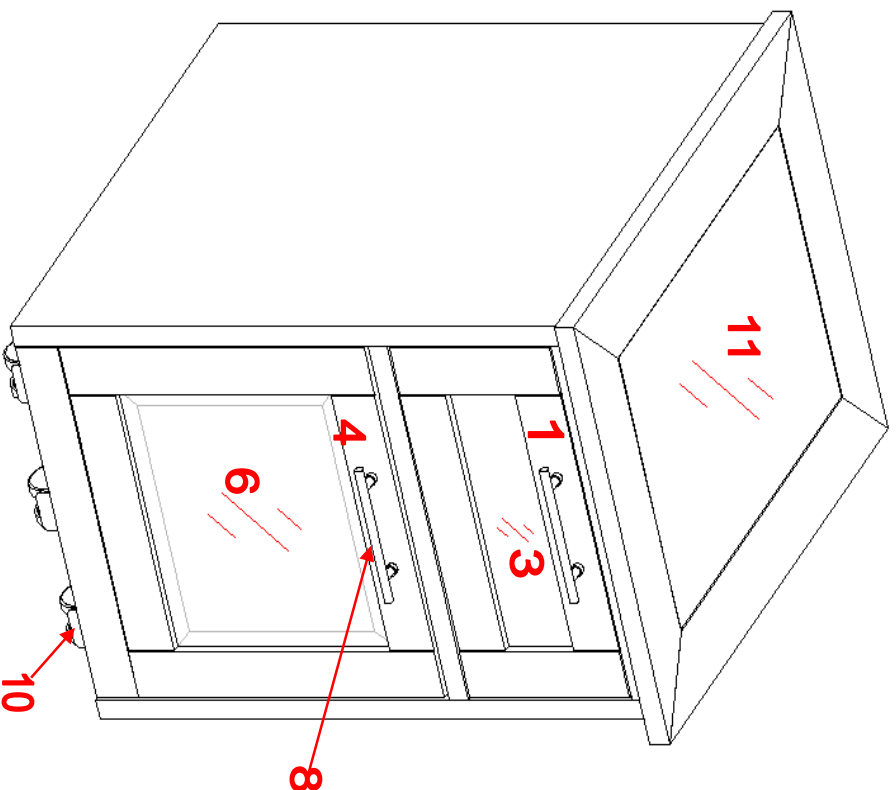

*ZTRF-1-TD	Top Drawer	*ZTRF-7-GL	Glass Liner
*ZTRF-2-TDS	Top Drawer Slides (35mm x 14" L)	*ZTRF-8-HB	Handle w/Bolts
*ZTRF-3-TDG	Top Drawer Glass	*ZTRF-9-FR	File Rod (inside drawers)
*ZTRF-4-BD	Bottom Drawer	*ZTRF-10-CS	Caster w/Screws
*ZTRF-5-DS	Bottom Drawer Slides (45mm x 18" L)	*ZTRF-11-TG	Top Glass
*ZTRF-6-BDG	Bottom Drawer Glass	*ZTRF-12-TUP	Touch-up Pen

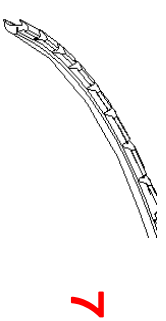

7

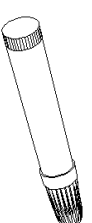

12