



INSTRUCTIONS D'ASSEMBLAGE
ASSEMBLY INSTRUCTIONS

MONARCH
SPECIALTIES INC.

I 2417

ETAGERE -
72"H / ESPRESSO EN COIN

BOOKCASE -
72"H / ESPRESSO CORNER ACCENT ETAGERE



**POUR DE L'ASSISTANCE OU POUR COMMANDER
DES PIÈCES CONTACTEZ NOTRE DÉPARTEMENT
DE SERVICE À LA CLIENTÈLE.**

**FOR ASSISTANCE OR TO ORDER PARTS
CONTACT OUR CUSTOMER SERVICE DEPARTMENT**

WWW.MONARCHSERVICE.COM

LISTE DES PIÈCES
PARTS LIST

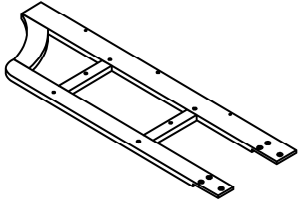
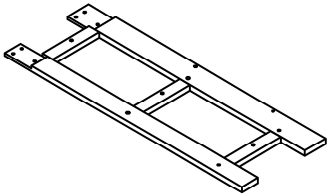
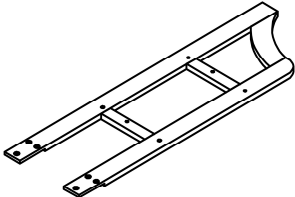
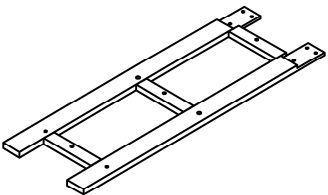
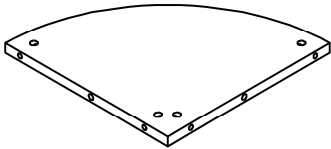
PIÈCE / PART #	IMAGE	DESCRIPTION	QTY / QTÉ
1		FRONT FACING LEFT LEG PATTE AVANT GAUCHE	1
2		FRONT FACING LEFT LEG PATTE AVANT GAUCHE	1
3		FRONT FACING RIGHT LEG PATTE AVANT DROITE	1
4		FRONT FACING RIGHT LEG PATTE AVANT DROITE	1
5		SHELF PANEL PANNEAU DE TABLETTE	2

LISTE DES PIÈCES
PARTS LIST

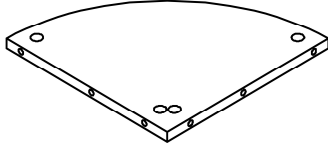
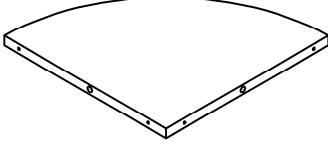
PIÈCE / PART #	IMAGE	DESCRIPTION	QTY / QTÉ
6		<p>SHELF PANEL PANNEAU DE TABLETTE</p>	2
7		<p>SHELF PANEL PANNEAU DE TABLETTE</p>	1

LISTE DES PIÈCES DE MONTAGE
HARDWARE LIST

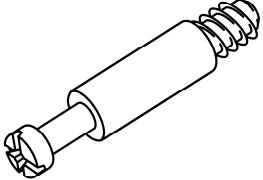
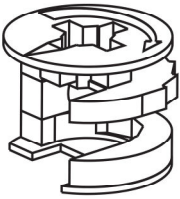
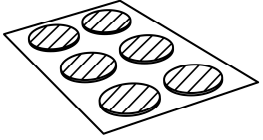
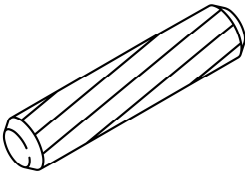
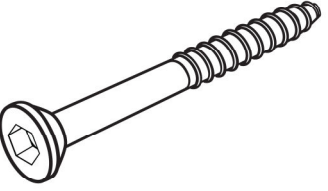
PIÈCE / PART #	IMAGE	DESCRIPTION	QTY / QTÉ
A		CAM LOCK SCREW - 1 1/8" VIS CAM LOCK - 1 1/8"	8
B		CAM LOCK CONNECTOR - Ø5/8" ÉCROU CAM LOCK - Ø5/8"	8
C		FINISHING STICKER - Ø7/8" COLLANT DE FINITION - Ø7/8"	20
D		WOOD DOWEL - Ø3/8" X 1" GOUJON DE BOIS - Ø3/8" X 1"	12
E		ASSEMBLING SCREW - 2 1/8" VIS D'ASSEMBLAGE - 2 1/8"	8

LISTE DES PIÈCES DE MONTAGE
HARDWARE LIST

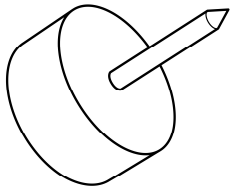
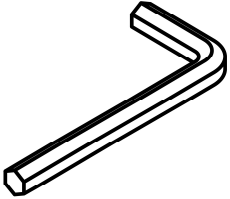
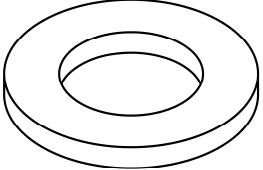
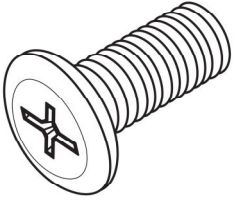
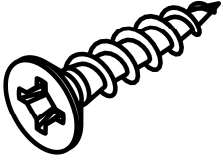
PIÈCE / PART #	IMAGE	DESCRIPTION	QTY / QTÉ
F		FLOOR PROTECTOR - Ø5/8" PROTECTEUR DE PLANCHER - Ø5/8"	4
G		HEX KEY CLÉ HEXAGONALE	1
H		METAL WASHER - Ø5/8" RONDELLE DE MÉTAL - Ø5/8"	8
I		ASSEMBLING BOLT - 1/2" BOULON D'ASSEMBLAGE - 1/2"	8
J		ASSEMBLING SCREW - Ø1/8" X 1 3/8" VIS D'ASSEMBLAGE - Ø1/8" X 1 3/8"	8

LISTE DES PIÈCES DE MONTAGE
HARDWARE LIST

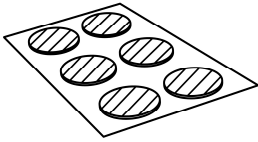
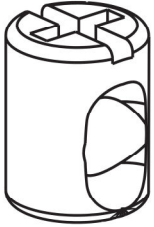
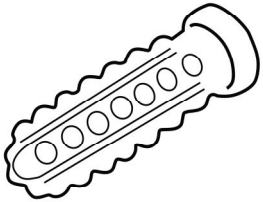
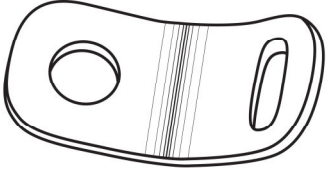
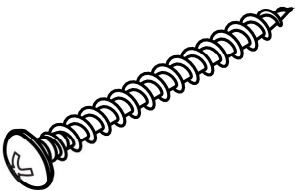
PIÈCE / PART #	IMAGE	DESCRIPTION	QTY / QTÉ
K		FINISHING STICKER - Ø1/2" COLLANT DE FINITION - Ø1/2"	12
L		BARREL NUT - Ø3/8" X 1/2" ÉCROU DE CANON - Ø3/8" X 1/2"	8
M		ANCHOR - Ø3/8" X 1 1/2" ANCRE - Ø3/8" X 1 1/2"	1
N		METAL BRACKET - 1/2" X 1/2" SUPPORT EN MÉTAL - 1/2" X 1/2"	2
O		ASSEMBLING SCREW - Ø1/8" X 1 1/2" VIS D'ASSEMBLAGE - Ø1/8" X 1 1/2"	1

LISTE DES PIÈCES DE MONTAGE
HARDWARE LIST

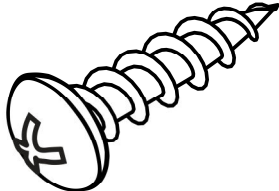
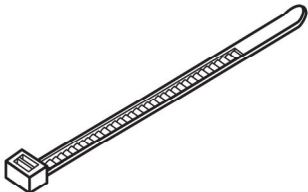
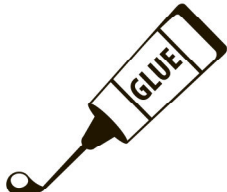
PIÈCE / PART #	IMAGE	DESCRIPTION	QTY / QTÉ
P		<p>ASSEMBLING SCREW - Ø1/8" X 1"</p> <p>VIS D'ASSEMBLAGE - Ø1/8" X 1"</p>	1
Q		<p>ZIP TIE - 7 3/4" X 1/8"</p> <p>ATTACHE AUTOBLOQUANTE - 7 3/4" X 1/8"</p>	1
R		<p>GLUE - 10G</p> <p>COLLE - 10G</p>	1



OUTIL DE VÉRIFICATION DE DIMENSIONS DES PIÈCES
HARDWARE DIMENSIONS VERIFICATION TOOL



ÉTAPE / STEP 1

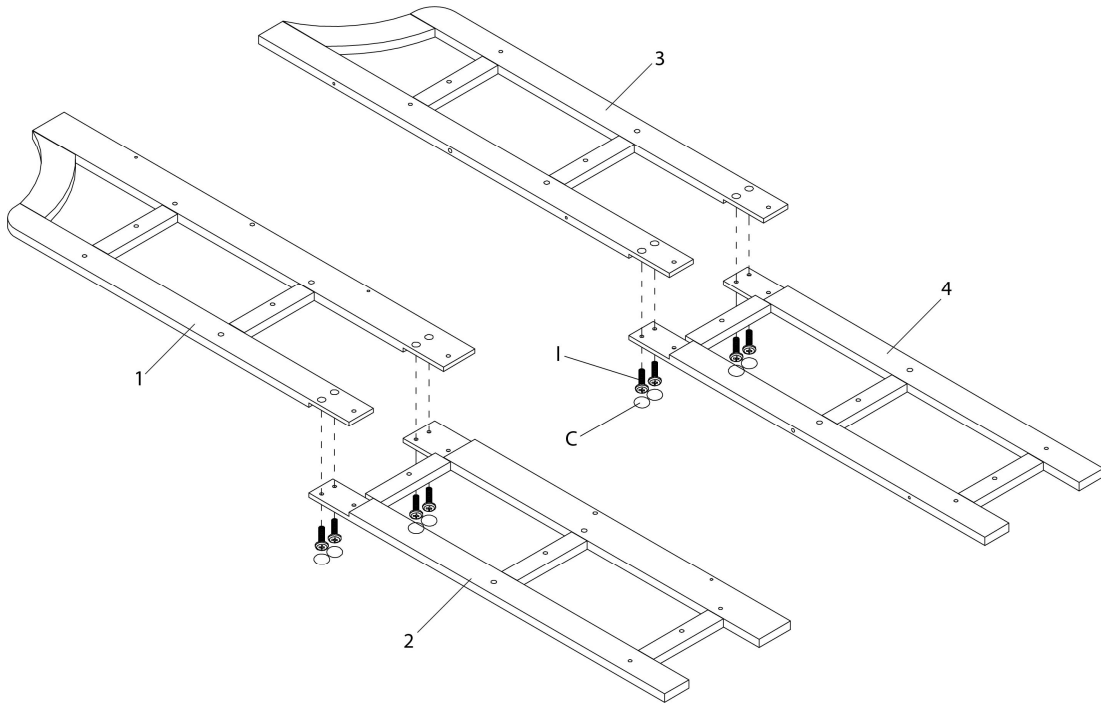

ÉTAPE / STEP 2

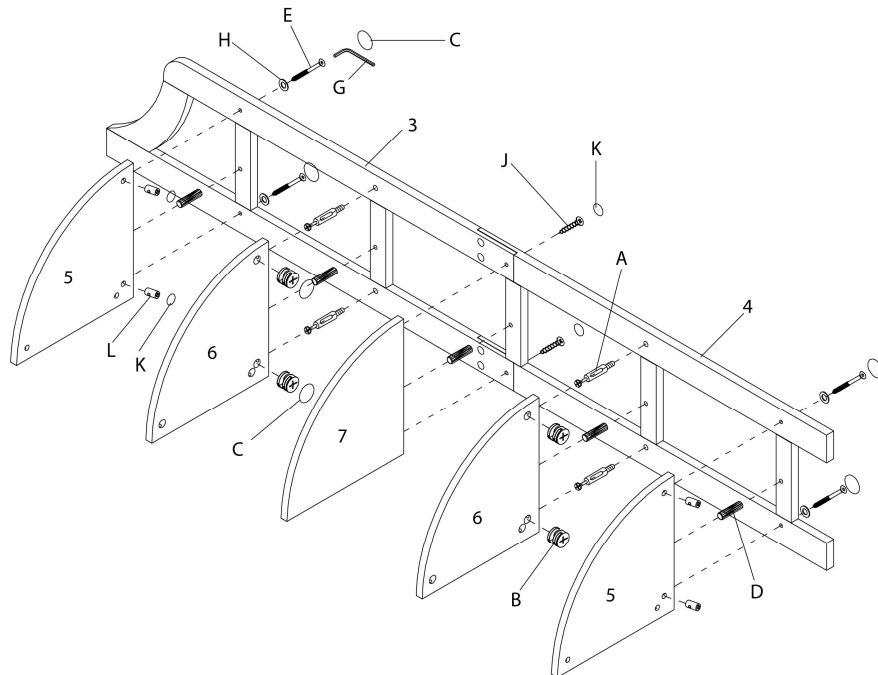

ÉTAPE / STEP 3

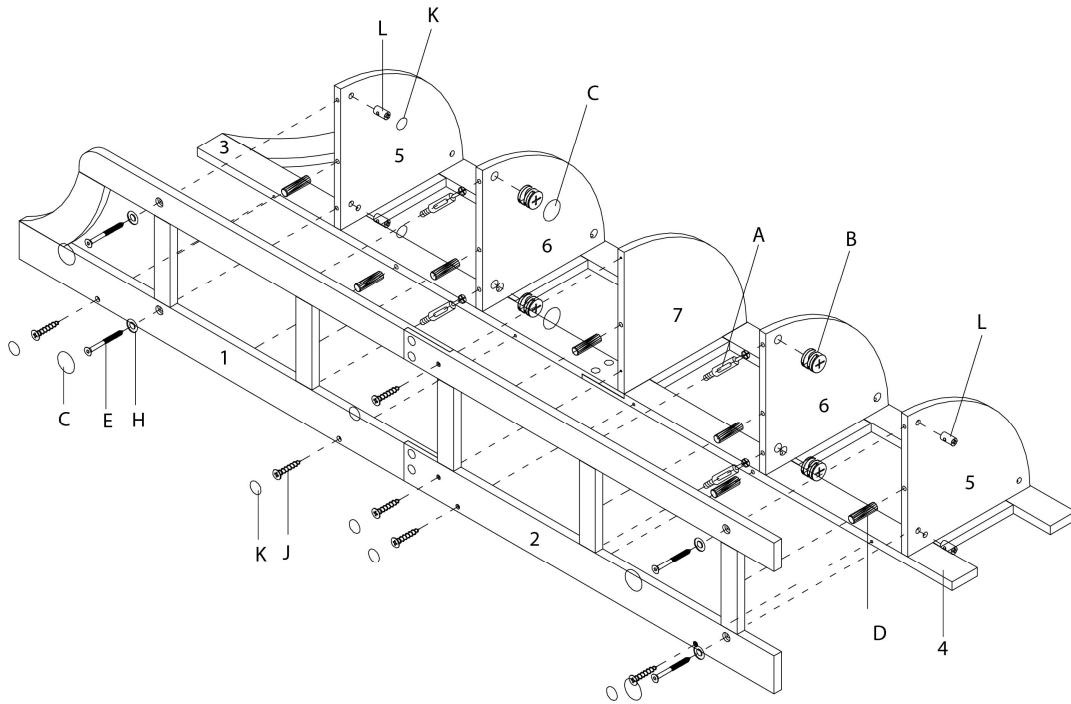

ÉTAPE / STEP 4

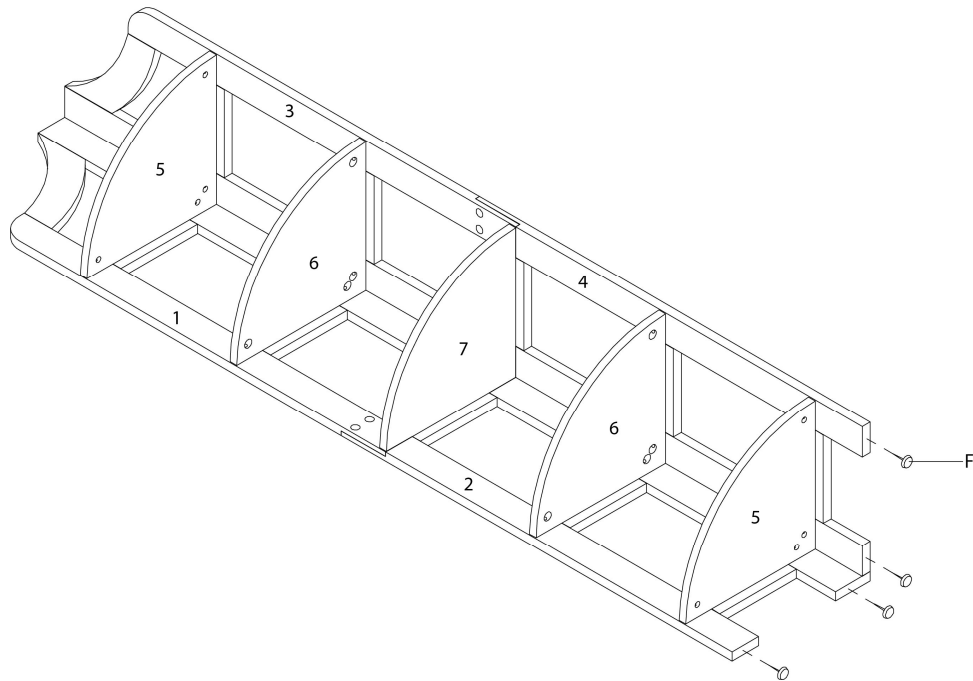

ÉTAPE / STEP 5

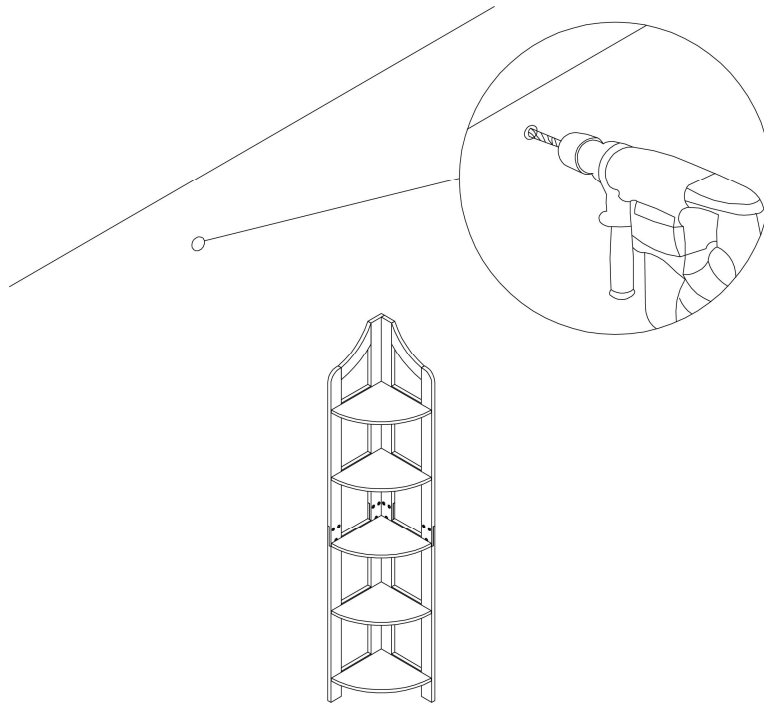

ÉTAPE / STEP 6

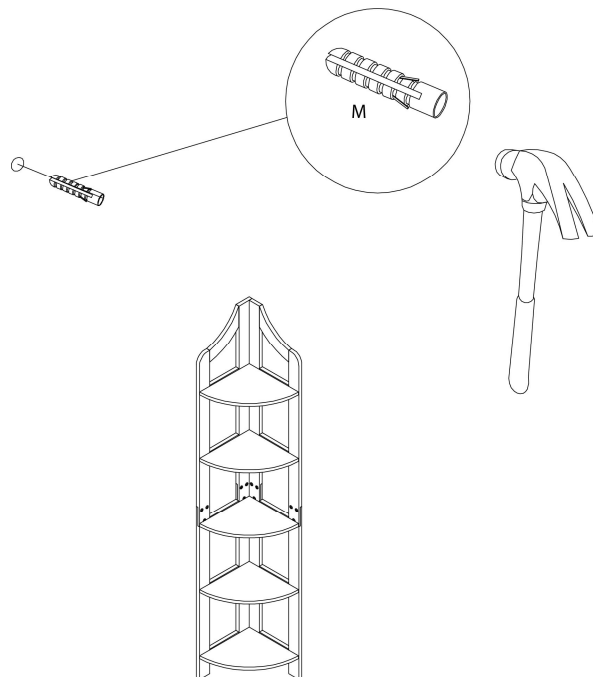

ÉTAPE / STEP 7

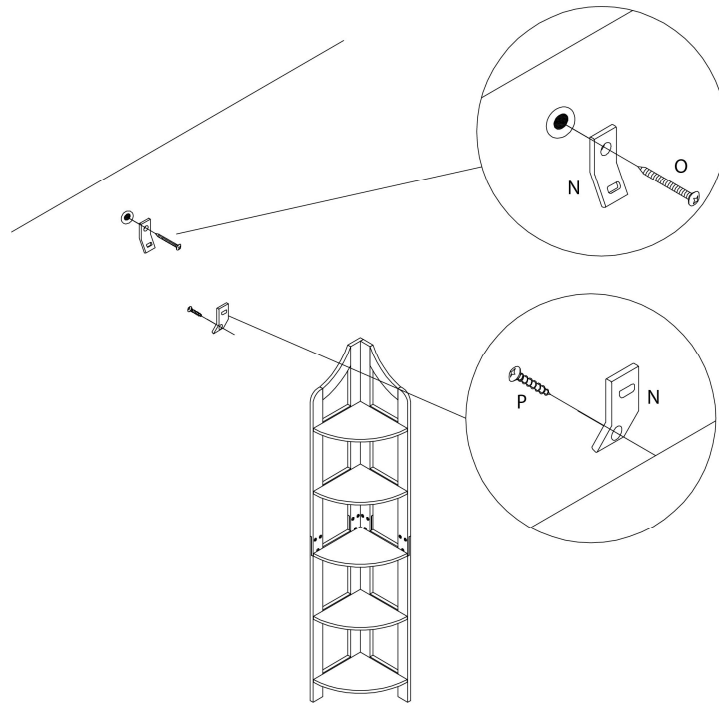

ÉTAPE / STEP 8

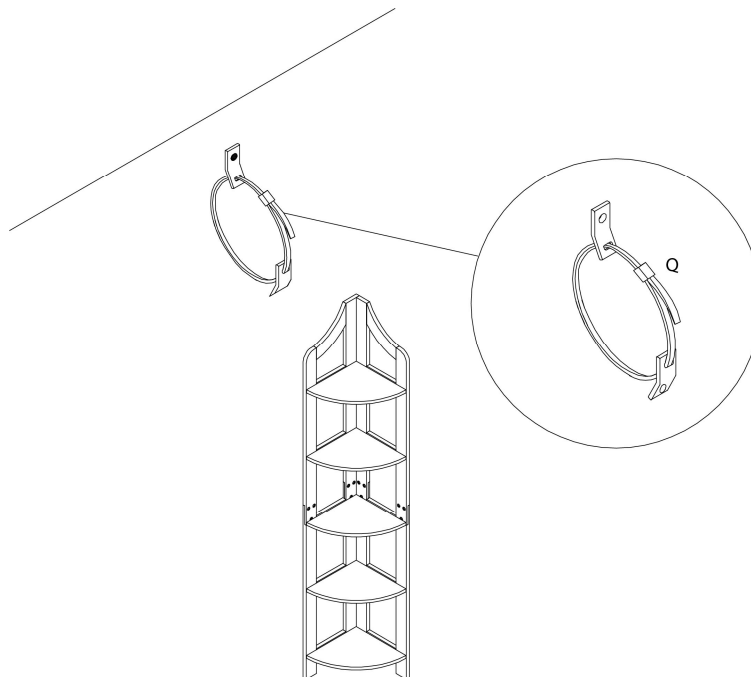

ÉTAPE / STEP 9

