

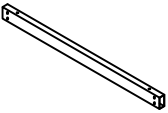

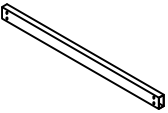

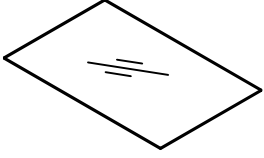
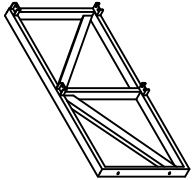
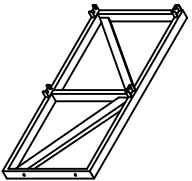
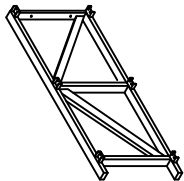
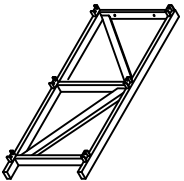

# ASSEMBLY INSTRUCTION

## 795-12 BOOKCASE

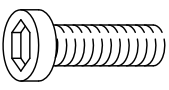
<b>A</b> Cross Bar  8PCS	<b>B</b> Cross Bar  2PCS	<b>C</b> Glass Shelf  4PCS	<b>D</b> Upper Frame Left  1PC
<b>E</b> Upper Frame Right  1PC	<b>F</b> Lower Frame Left  1PC	<b>G</b> Lower Frame Right  1PC	<b>H</b> Bolt 1/4"*10mm  40PCS
<b>I</b> Bolt 1/4"*20mm  4PCS	<b>J</b> Glass Holder Ø16*10mm  16PCS	<b>K</b> L-Allen Key 4mm  1PC	<b>L</b> Anti-Tipping Kit  1SET

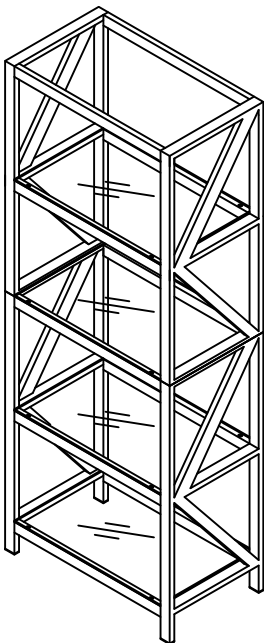

This page lists all the contents included in the box. Please take the time to identify the hardware as well as the individual components to this product. As you unpack and prepare for assembly, place the contents on a carpeted or padded area to protect them from damage.

- 1 Put the upper frames (D & E) on the smooth and stable working stand. Attach the cross bars (A & B) to the upper frames (D & E). Using the bolts (H) and L-allen key (K) to tighten.

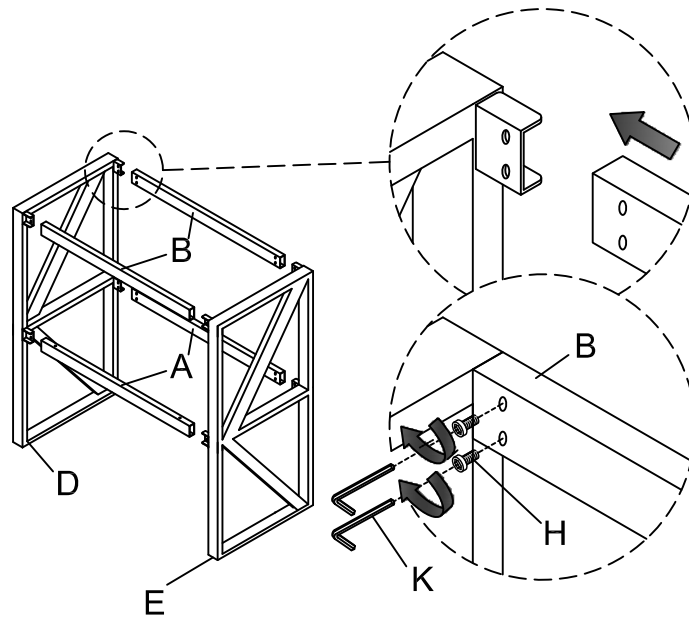

- 2 Attach the cross bars (A) to lower frames (F & G), using the bolts (H) and L-allen key (K) to tighten.

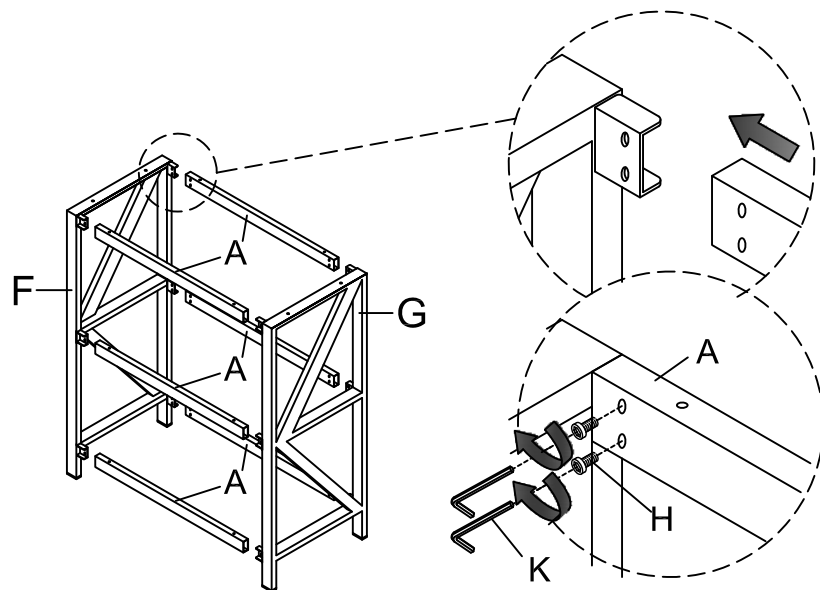

**3** Attach the upper frames (D & E) to lower frames (F & G), using the bolts (I) and L-allen key (K) to tighten.

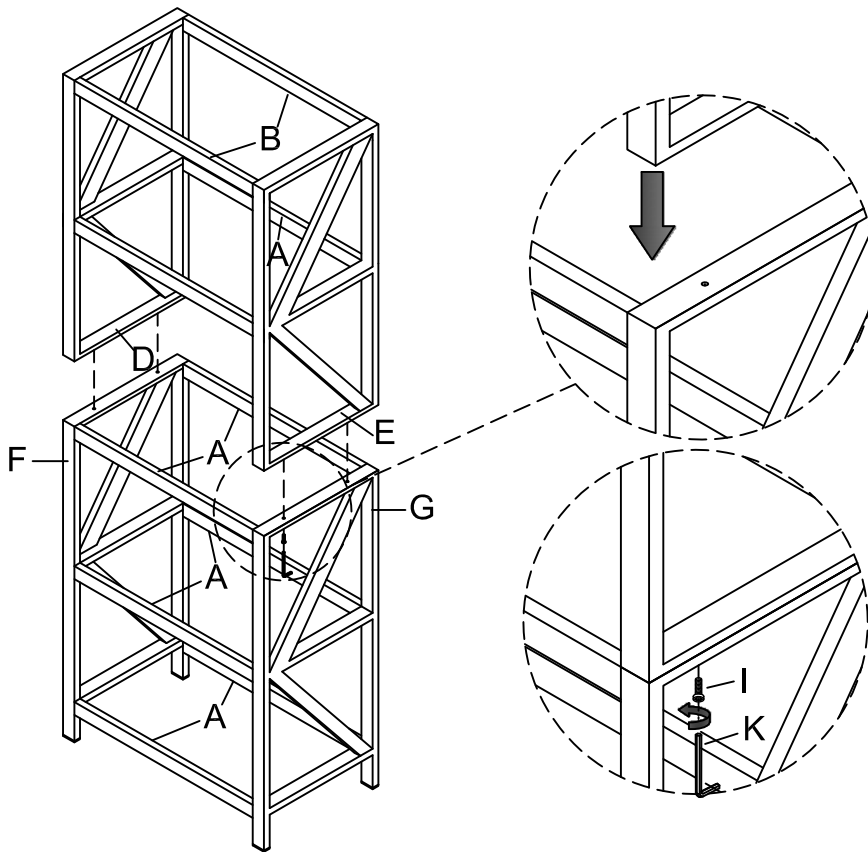

**4** Attach the glass holder (J) to the cross bar (A), put the glass shelf (C) onto the cross bar (A).

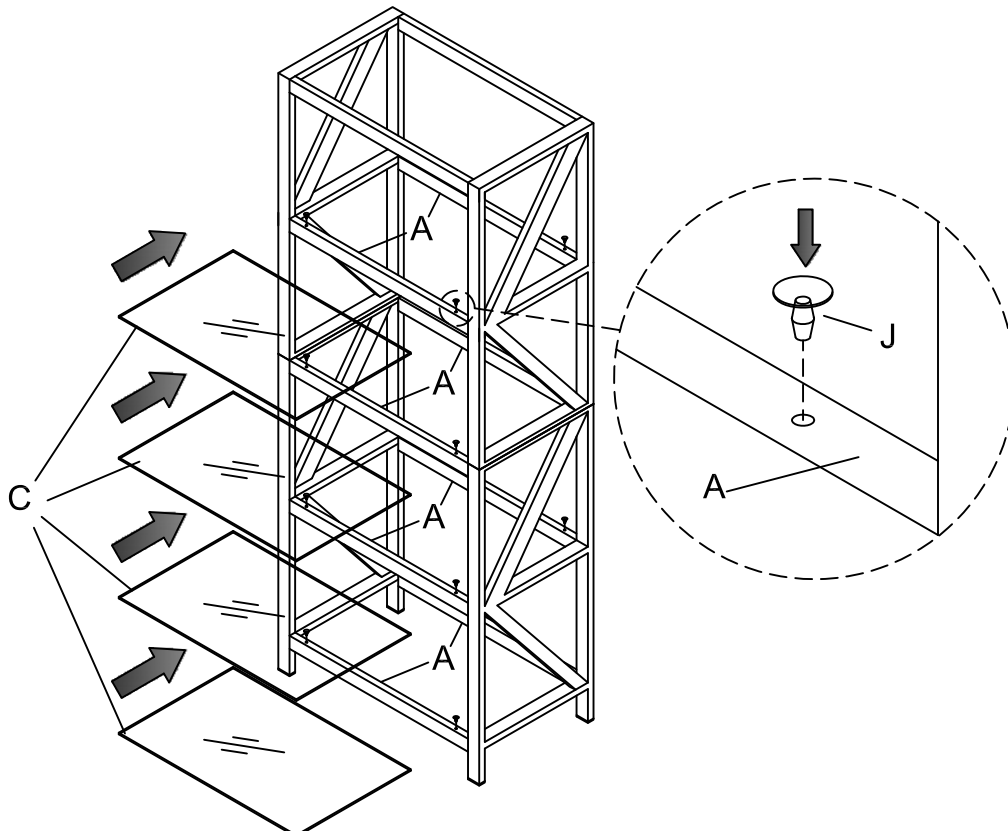

- 5** Attach anti-tipping kit (L) to wall: Attach bracket (vertically) to wall using 2 of the screws provided. Attach bracket (horizontally) to furniture back with 2 of the screws provided. Place bracket as close to left & right of furniture back as possible in relation to wall stud and the desired position in the room. Move furniture to its final position. Thread the strap through bracket, and pull it tight.

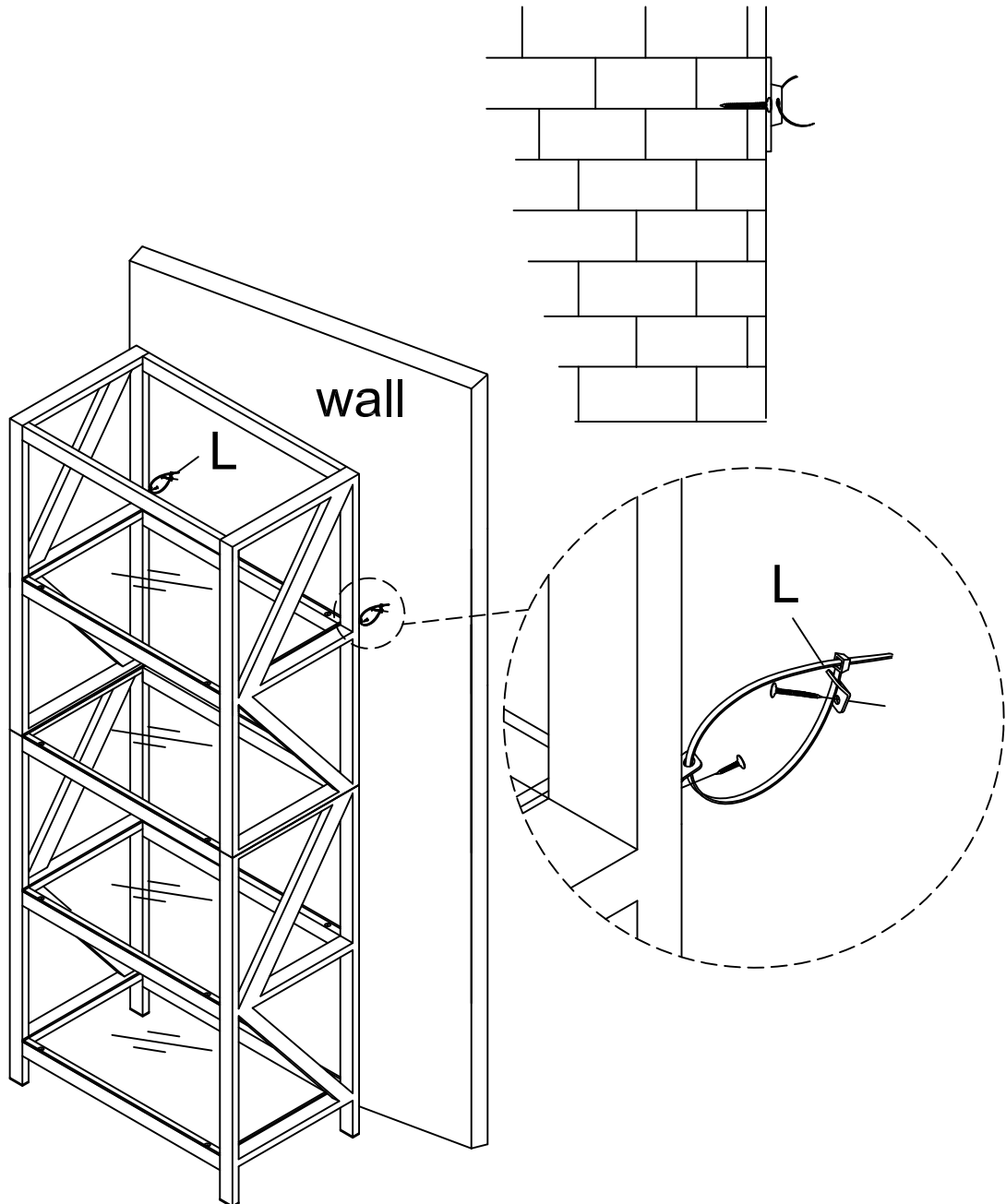

## Cleaning & Care

Treat surface with care. Surface is resistant to scratches but is not scratch resistant. Clean surfaces with a dry or damp soft cloth. Do not use abrasive cleaners. Hardware may loosen over time. Periodically check that all connections are tight.