





Manufactured by FSLC for Rooms To Go

****Caution: Please read all instructions carefully before starting the assembly process. These parts are cumbersome and heavy. Therefore, two people recommended in order to prevent personal injury and ensure the parts are not damaged during the assembly.**

| HARDWARE LIST | | | | |
|---------------|---|---|---------|------|
| ITEM | DESCRIPTION | IMAGE | SKU | # PZ |
| 1 | ALLEN KEY 5/32" |  | TOR-066 | 1 |
| 2 | JOINT CONNECTOR ALLEN BOLT 1/4" x 2-1/2" |  | TOR-045 | 8 |
| 3 | LOCK WASHER 1/4" |  | RON-002 | 8 |
| 4 | WASHER 1/4" |  | RON-005 | 8 |
| PART LIST | | | | |
| A | LEG |  | | 4 |

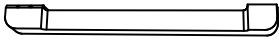
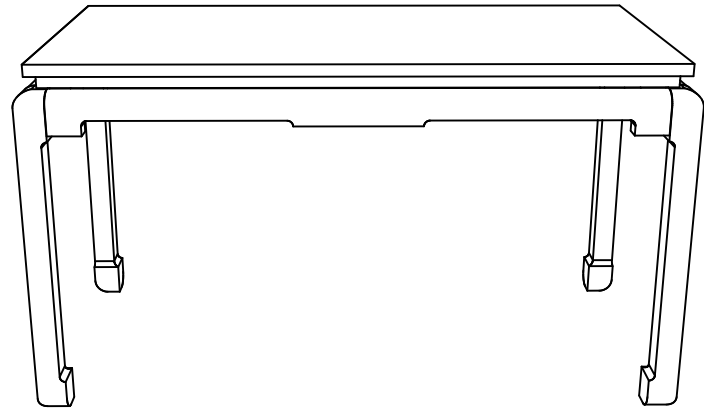

INSTRUCTIONS:

1. PLACE THE TOP OF THE DESK (B) UPSIDE DOWN OVER A CLEAN SURFACE.
2. PLACE THE LEGS (A) IN THE HOLE OF TE BASE (B) AS SHOWN IN FIG.1.
3. PLACE THE BOLTS (2) USING LOCK WASHERS (3), AND WASHERS (4) THROUGH THE HOLES IN THE LEGS AND THE BASE AND THEN TIGHTEN STRONGLY WITH THE ALLEN WRENCH, AS SHOWN IN FIG. 2.

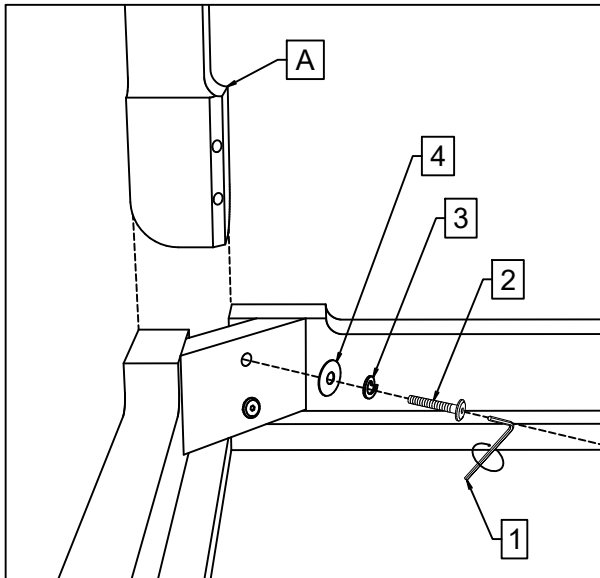

FIG. 2

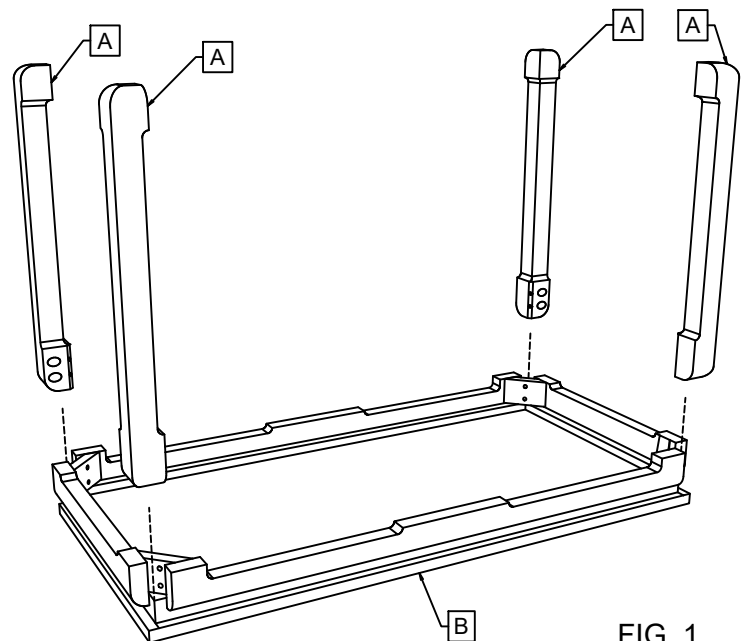

FIG. 1