









ASSEMBLY INSTRUCTIONS

B6830 / B6832 / B6835 - DESK

RANGLEY

CRWN

BOX OF WRITING DESK							
PARTS LIST				HARDWARE LIST			
NO.	DESCRIPTION	SKETCH	QTY	NO.	DESCRIPTION	SKETCH	QTY
1	BODY		1	A	JCBC (M6 x 40mm) W/FLAT WASHER & SPRING WASHER		10
2	SIDE PANEL LEFT		1	B	ALLEN KEY (M4)		1
3	SIDE PANEL RIGHT		1	C	PANHEAD (M4 x 30mm)		2
4	BACK PANEL		1	D	SCREW DRIVER (*)		1

*The manufacturer does not provide item D.

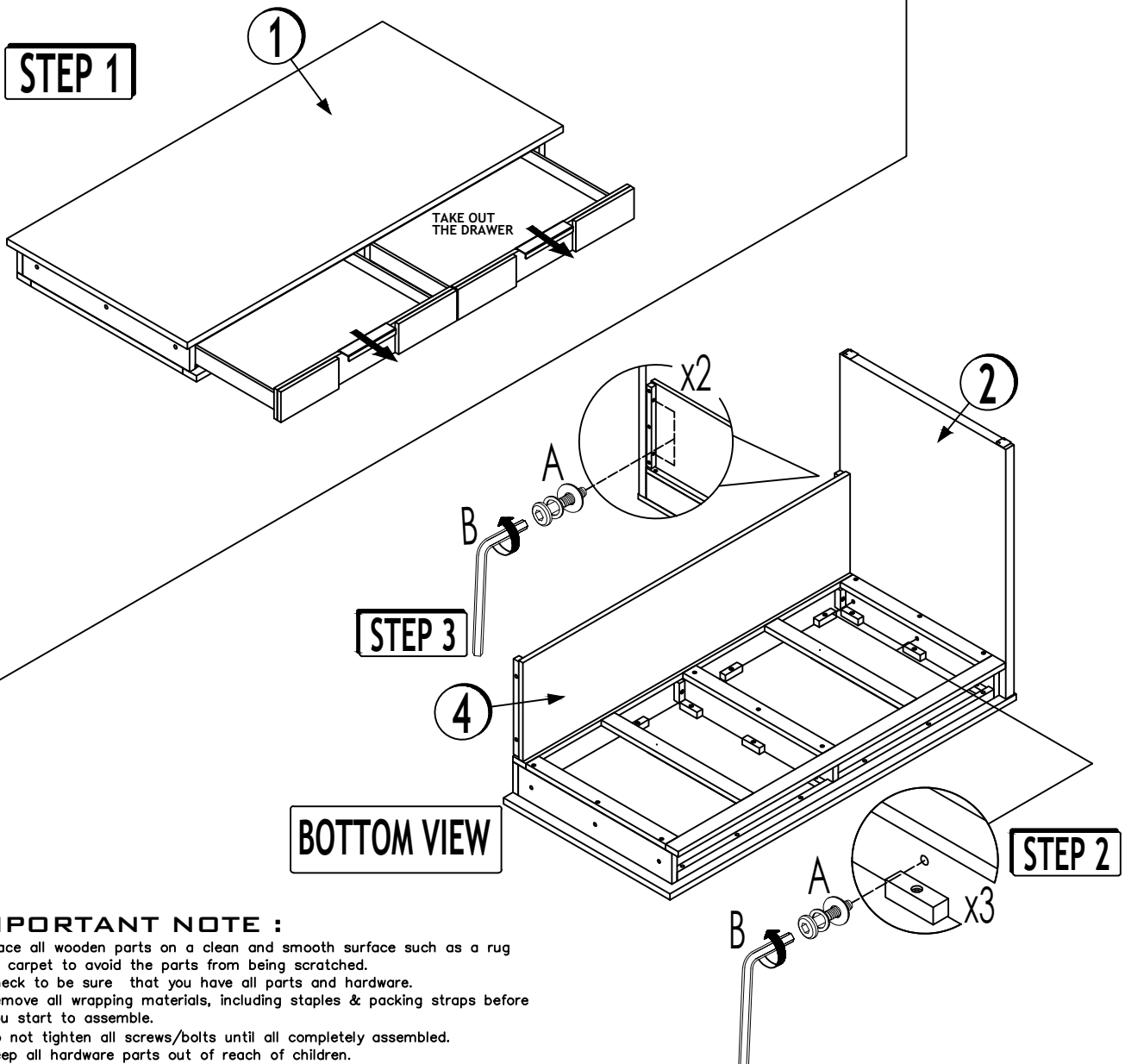

IMPORTANT NOTE :

- * Place all wooden parts on a clean and smooth surface such as a rug or carpet to avoid the parts from being scratched.
- * Check to be sure that you have all parts and hardware.
- * Remove all wrapping materials, including staples & packing straps before you start to assemble.
- * Do not tighten all screws/bolts until all completely assembled.
- * Keep all hardware parts out of reach of children.
- * Periodically check to ensure that all connectors (bolts, screws, etc.) are tight.

THE HARDWARE IS LOCATED IN THE PACKING ITEMS

ASSEMBLY INSTRUCTIONS
B6830 / B6835 - DESK
RANGLEY

CRWN

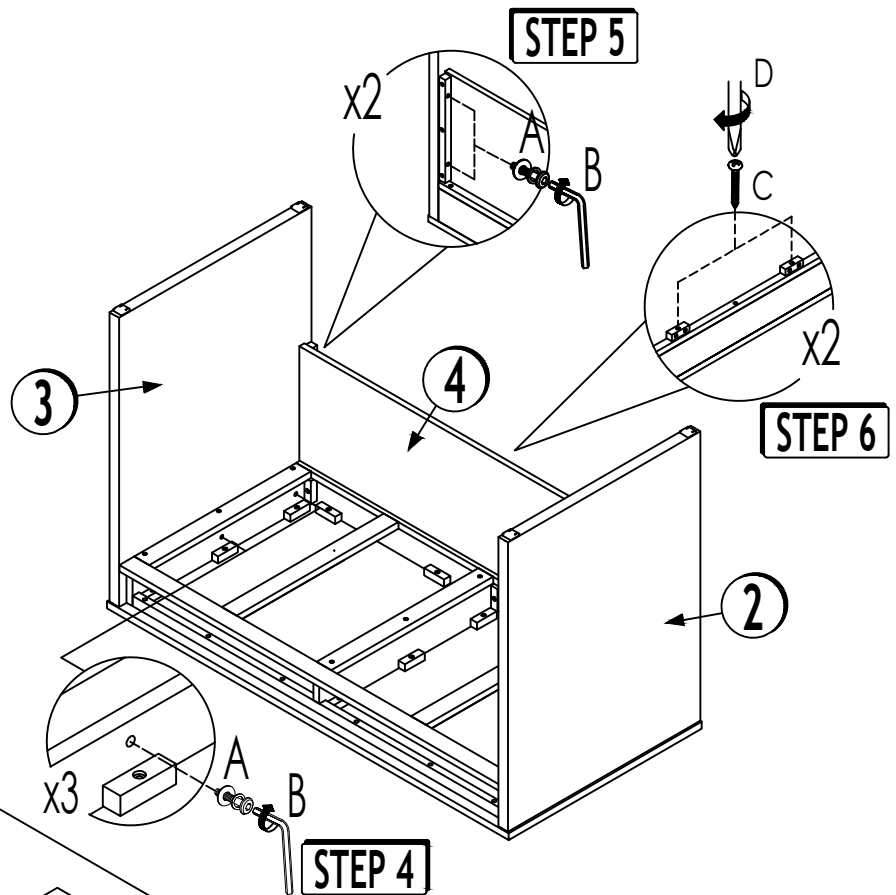

STEP 7

TAKE IN THE DRAWER

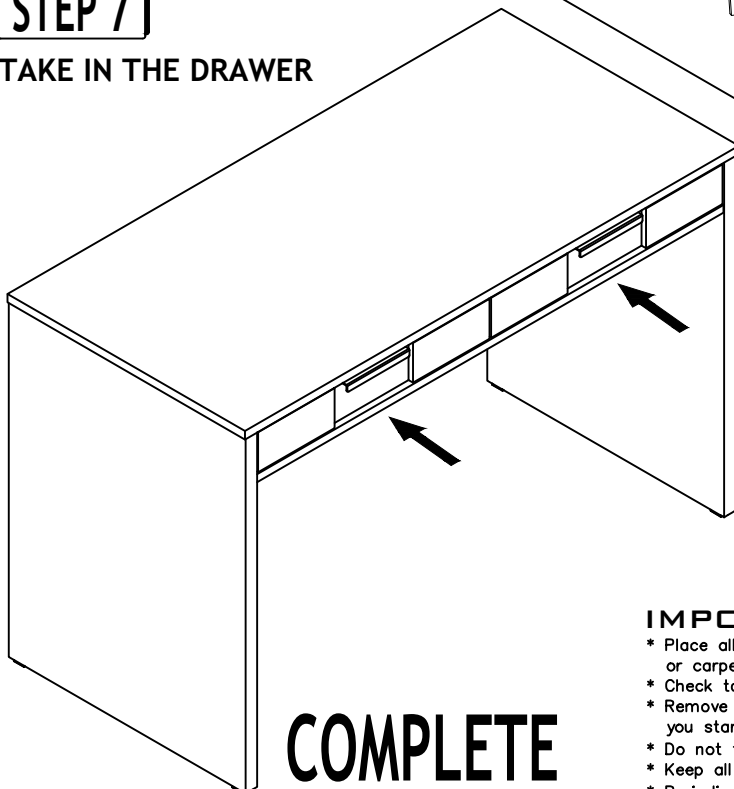

COMPLETE

IMPORTANT NOTE :

- * Place all wooden parts on a clean and smooth surface such as a rug or carpet to avoid the parts from being scratched.
- * Check to be sure that you have all parts and hardware.
- * Remove all wrapping materials, including staples & packing straps before you start to assemble.
- * Do not tighten all screws/bolts until all completely assembled.
- * Keep all hardware parts out of reach of children.
- * Periodically check to ensure that all connectors (bolts, screws, etc.) are tight.

THE HARDWARE IS LOCATED IN THE PACKING ITEMS

Page 2 of 2