

# Item # : BTSPIN Assembly Instructions

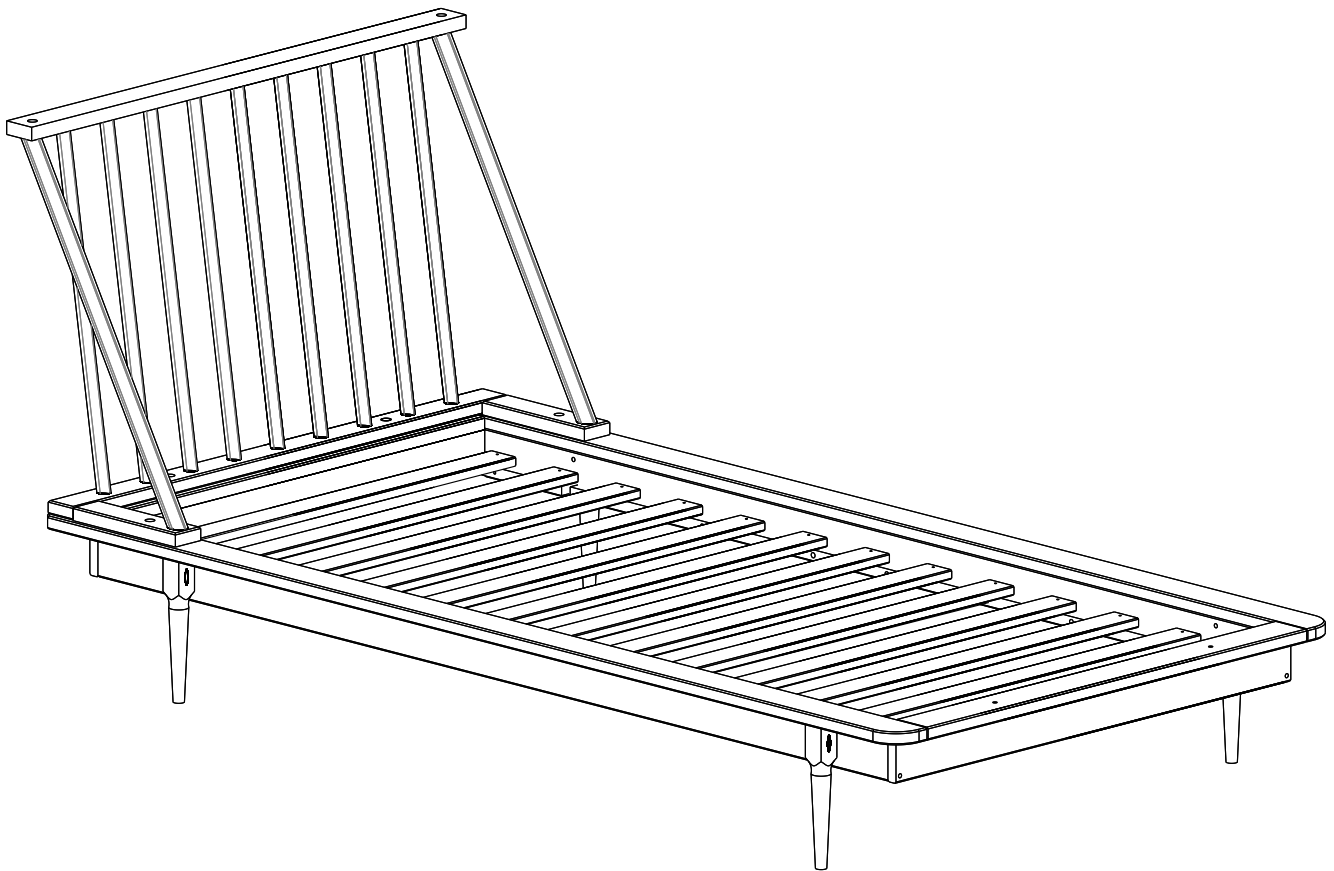

Walker  
Edison®

Please visit our website for the most current instructions, assembly tips, report damage, or request parts. [www.walkeredison.com](http://www.walkeredison.com)

Copyright © 2018, by Walker Edison Furniture Co., LLC. All rights reserved.

# General Assembly Guidelines

- I. Ensure that all parts and hardware are available before beginning assembly.
- II. Follow each step carefully to ensure the proper assembly of this product.
- III. Two people are recommended for ease in the assembly of this product.
- IV. The three main types of hardware used to assemble this product are : wood dowels , screws and bolts.
- V. A Phillips head screwdriver is required for the assembly of this product .

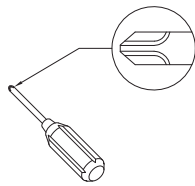

- VI. Power tools should not be used to assemble this product .

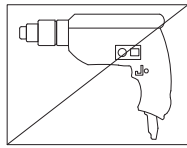



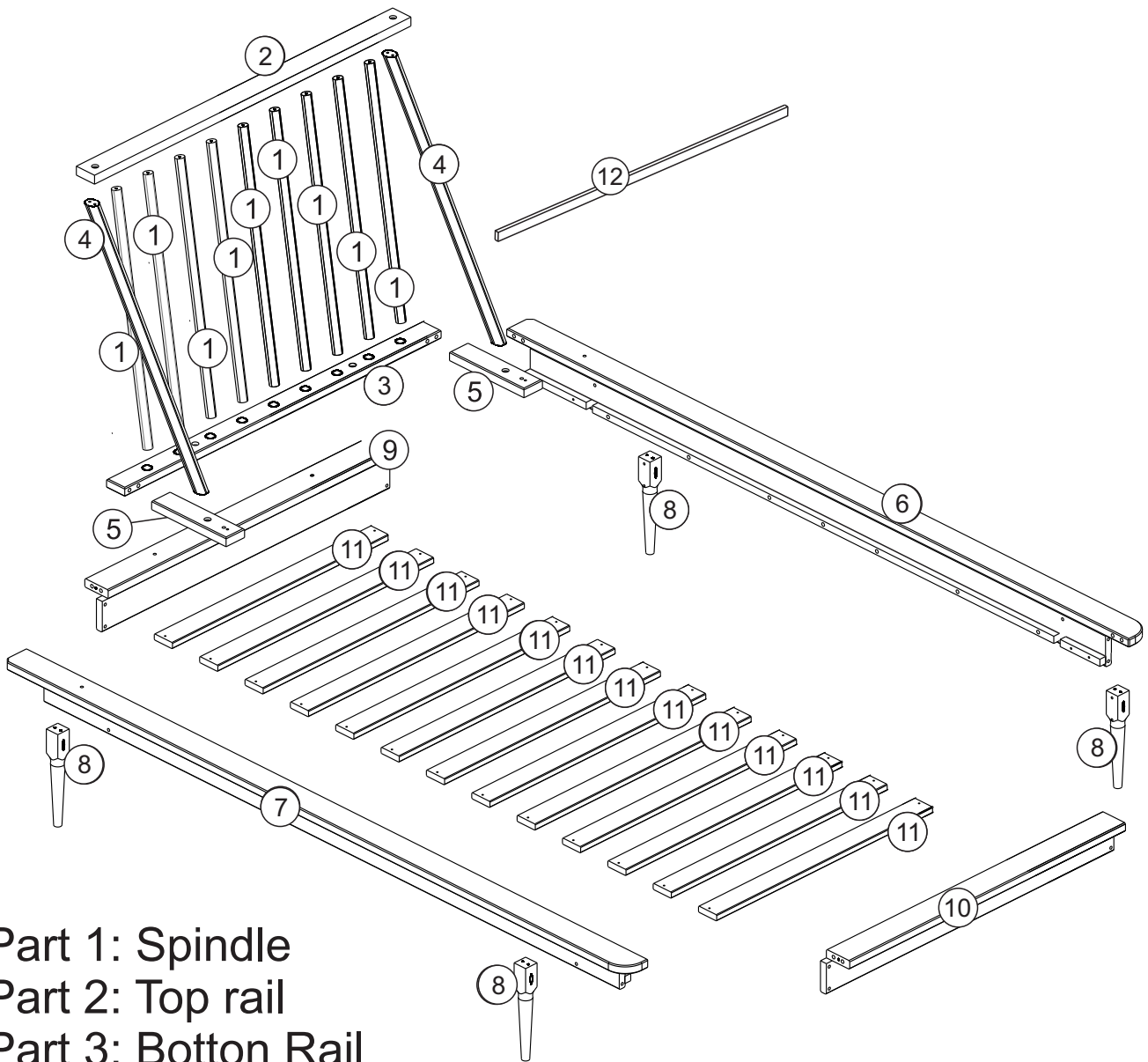













# Parts List

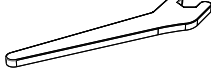

- Part 1: Spindle
- Part 2: Top rail
- Part 3: Bottom Rail
- Part 4: Support Bean
- Part 5: Bracket
- Part 6: Right Side Rail
- Part 7: Left Side Rail
- Part 8: Feet
- Part 9 : Back Rail
- Part 10: Front Rail
- Part 11: Slats
- Part 12: Bottom Headboard Slat

# Hardware List

|   |   |             |                       |        |
|---|---|-------------|-----------------------|--------|
| A |    | Ø7x70 mm    | Bolt                  | 08 pcs |
| B |    | Ø3.5x30 mm  | Screw                 | 30 pcs |
| C |    | Ø3.5x30 mm  | Screw                 | 17 pcs |
| D |    | Ø7x50 mm    | Bolt                  | 8 pcs  |
| E |    | Ø10x40mm    | Wood dowel            | 14 pcs |
| F |    | Ø6x30 mm    | Wood dowel            | 04 pcs |
| G |    | Ø1/4"x60 mm | Bolt                  | 05 pcs |
| H |    |             | Washer                | 05 pcs |
| I |    |             | Nut                   | 05 pcs |
| J |    |             | Hex key               | 02 pcs |
| K |  |             | Wrench                | 01 pcs |
| L |  |             | Spacer                | 02 pcs |
| M |  | Ø1/4"X50mm  | Screw                 | 04 pcs |
| N |  | Ø1/4 "      | Union Screw           | 04 pcs |
| O |  | Ø4.0x40 mm  | Screw                 | 06 pcs |
| P |  | Ø3.5x20 mm  | Screw                 | 11 pcs |
| Q |  | 50x50 mm    | Metal Plate Connector | 02 pcs |

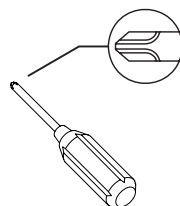

Philips head screwdriver required for assembly  
(not included)

*The hardware quantities listed above are required for proper assembly.  
Some extra hardware may also have been included.*

# Step 1

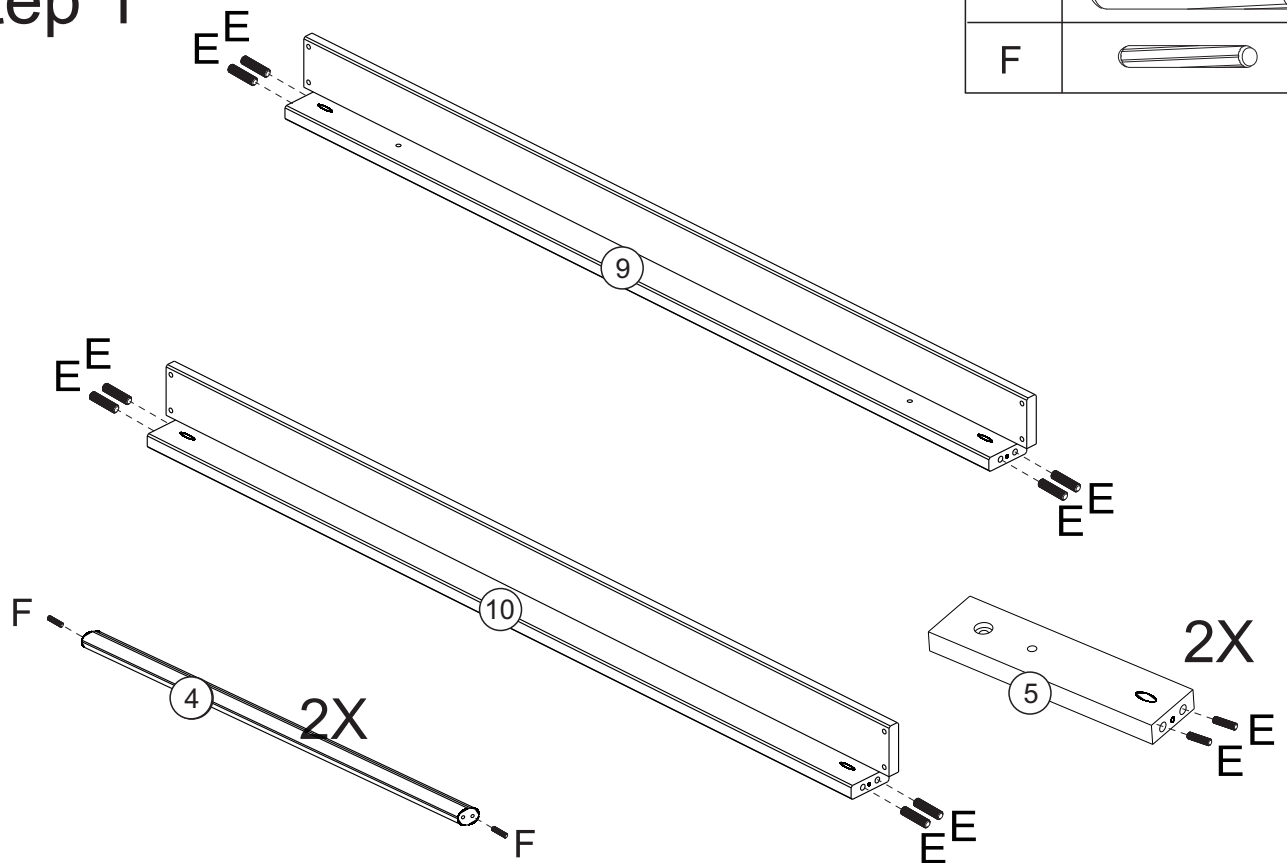

Insert wooden dowels (E) into rails (5,9,10), dowels (F) into parts (4),

# Step 2

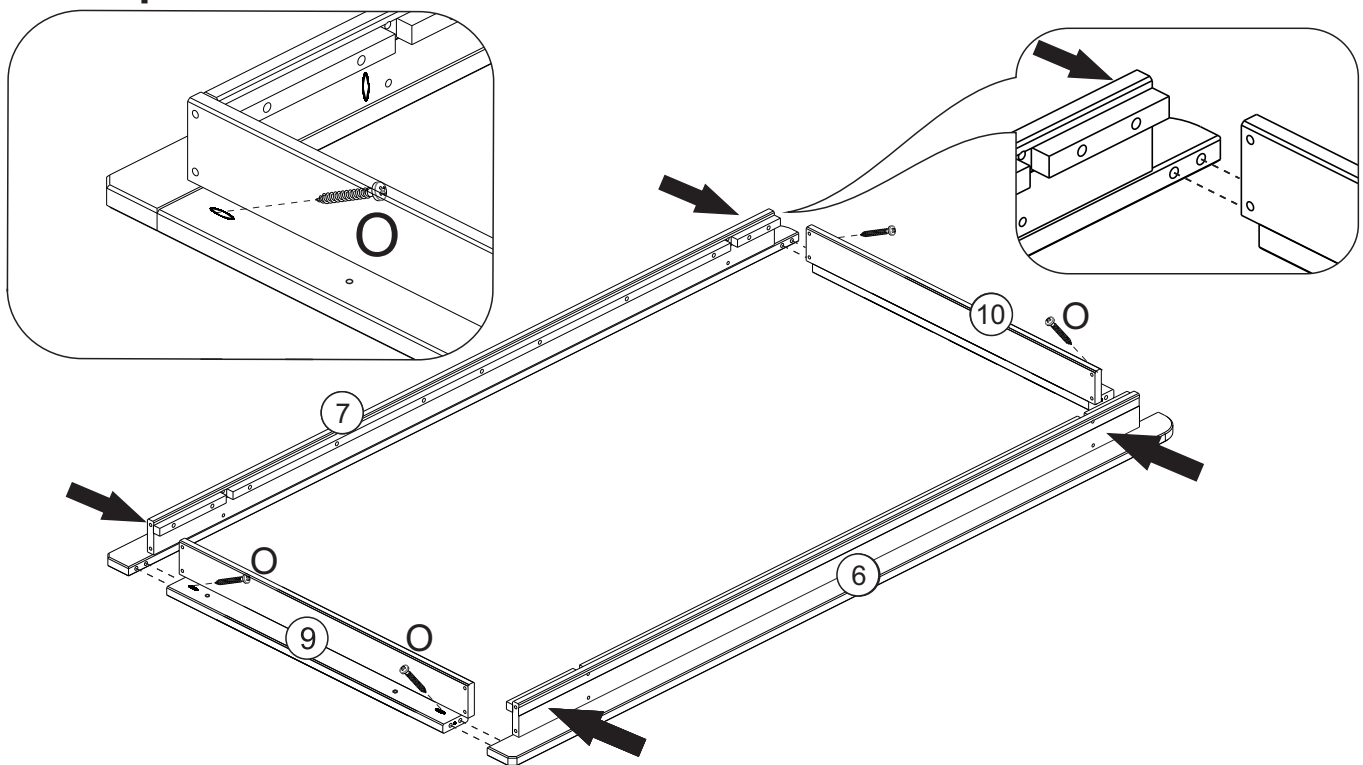

Connect parts (9,10) to parts (7,6)  
Secure parts with screw (O)

# Step 3

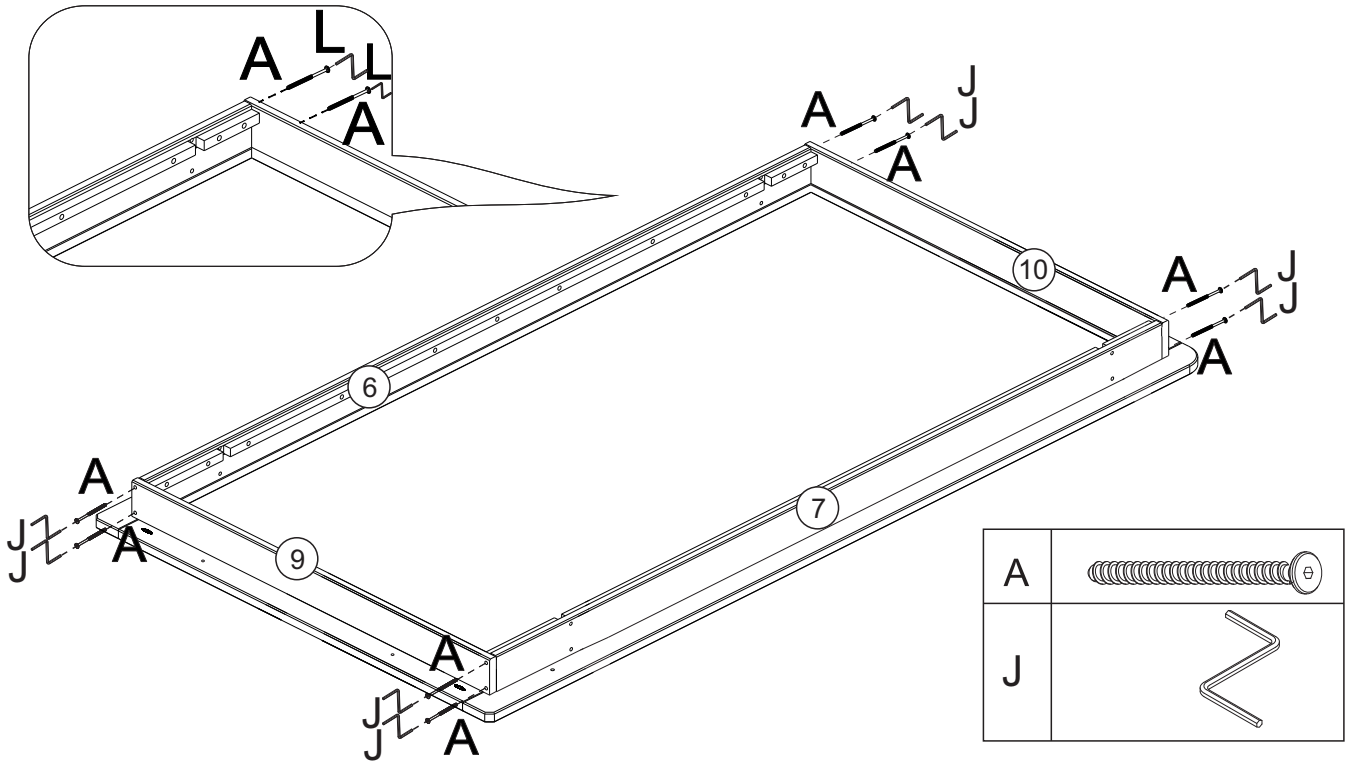

Connect parts (9,10) to parts (6,7) With Bolt (A) for this use the Hex key (J)

# Step 4

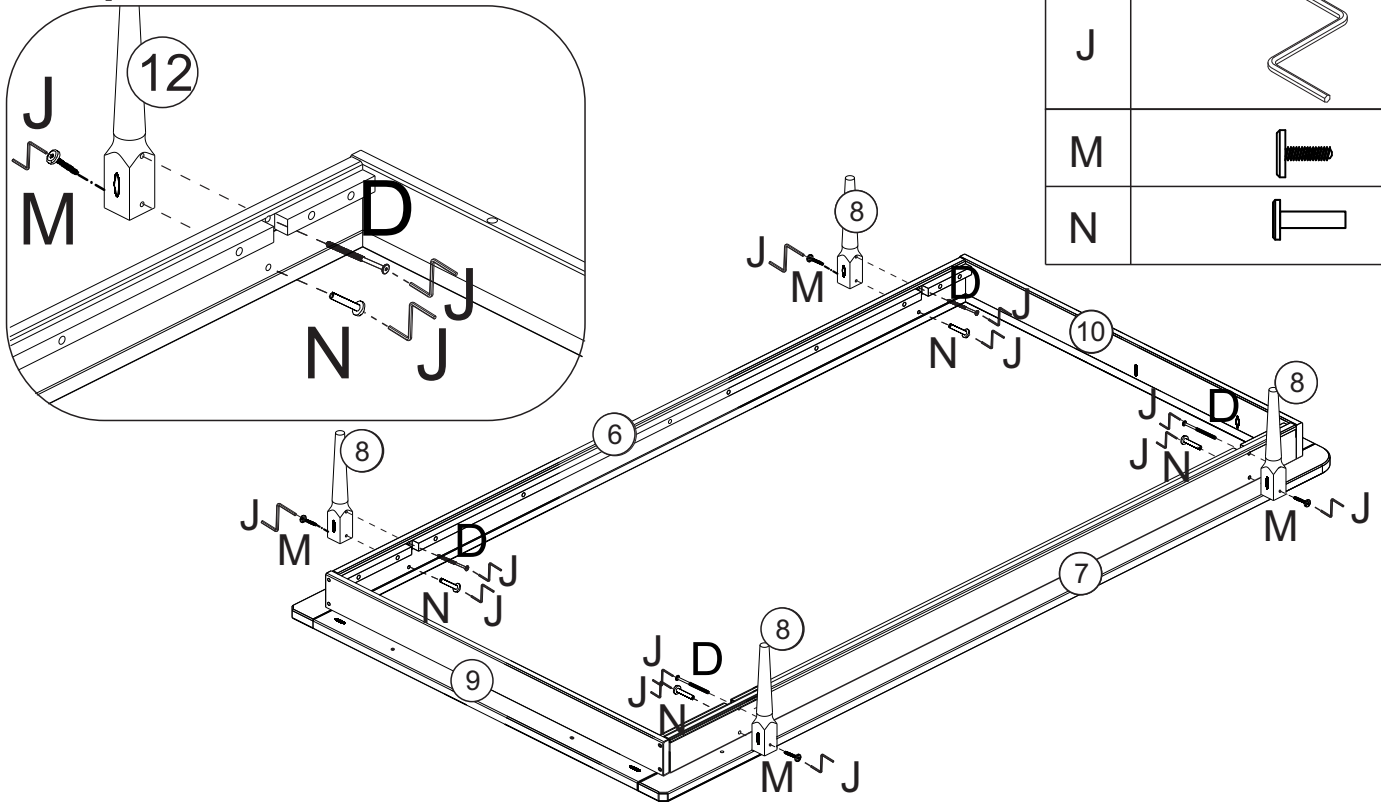

Attach Feet (8) to frame parts (7,6) using screw (M) and Union Screw (N). Union Screw (N) Should be on the inside of the bed frame, with screw (M), on the outside of the leg. Tighten by using with hex key (J) on both ends of the screw at the same time. The use Screw (D) and hex key (J) to secure legs (8).

# Step 05

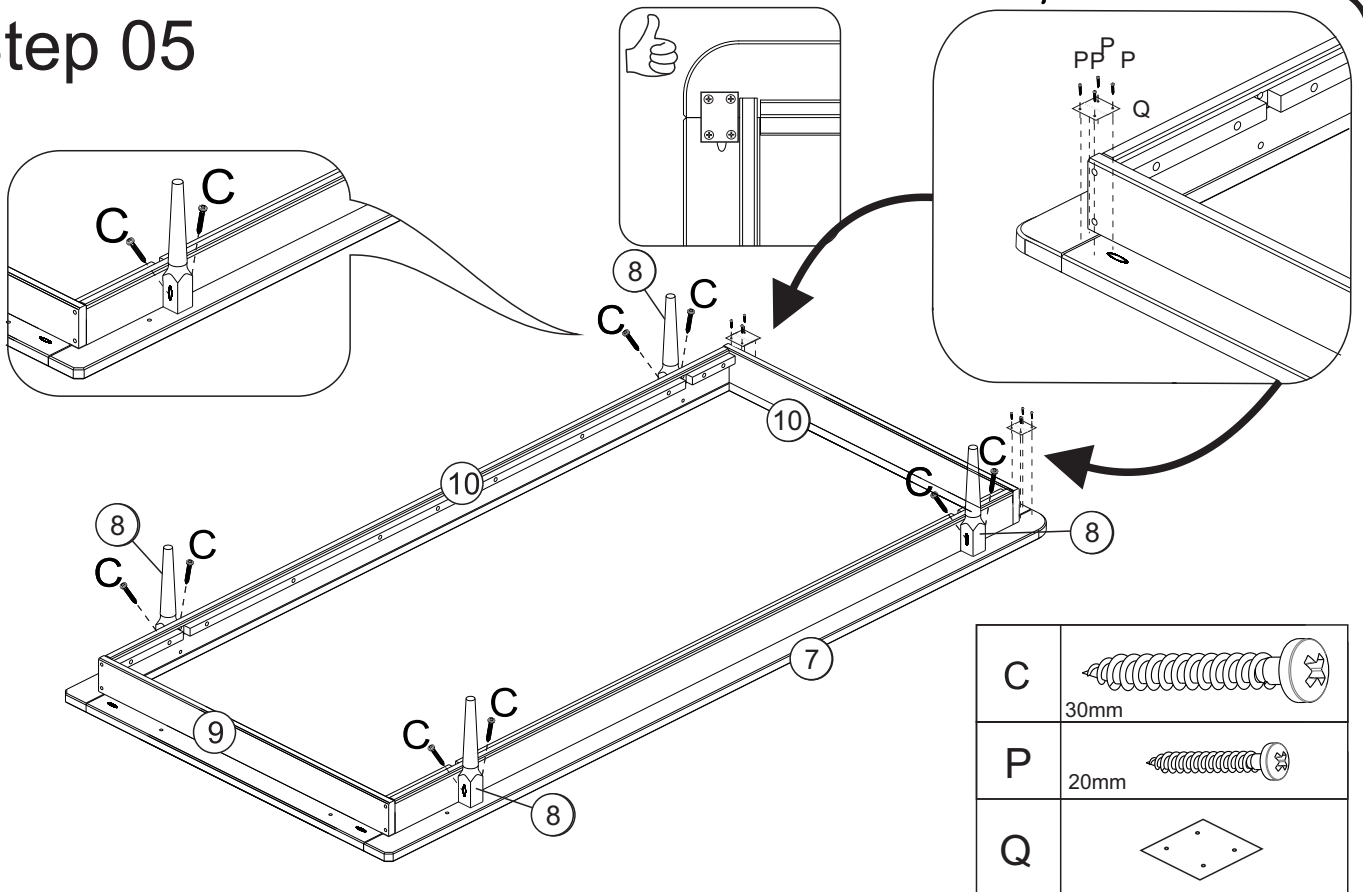

Secure feet to frame using screw(C).  
 Attach the metal connector plate (Q) to the 2 corners of the bed with screws (P). Take care to align the plate over the seam of the two parts, as shown in the drawing, before securing in place

# Step 06

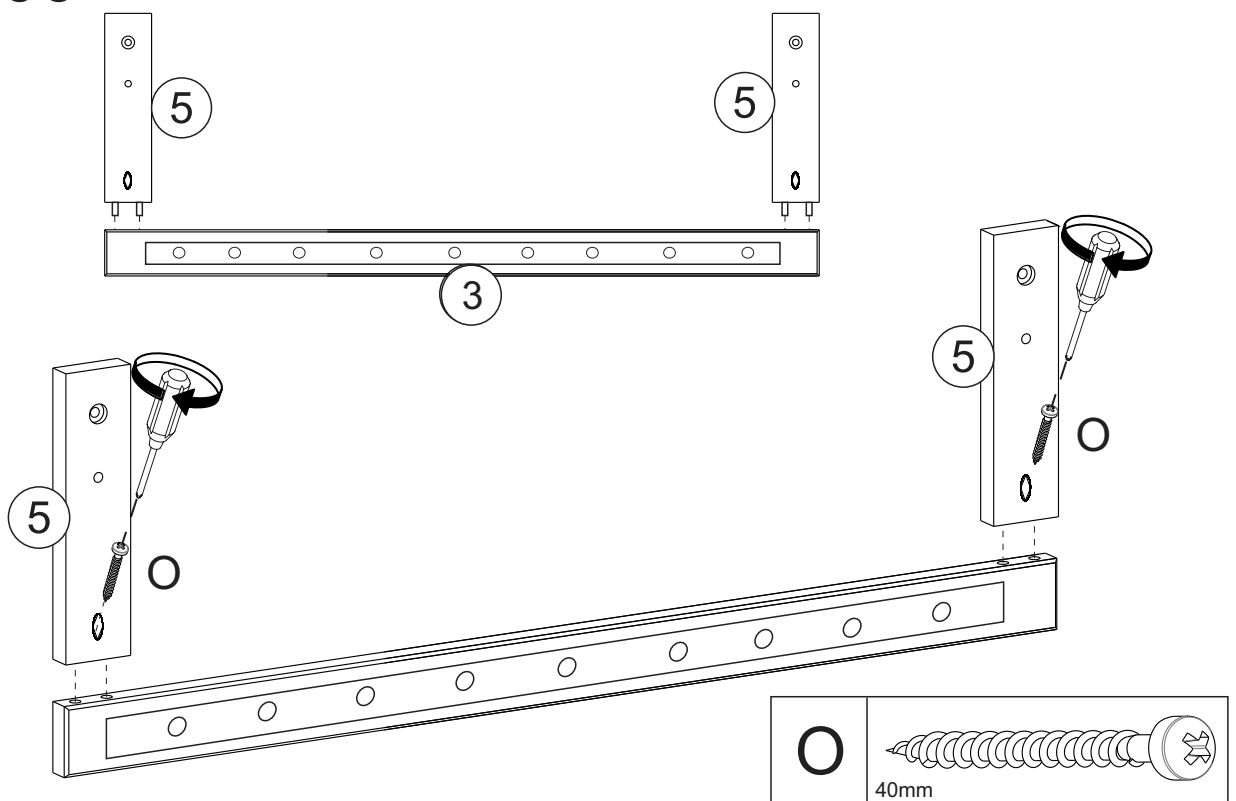

connect parts (5) and (3). Note the drawing for location of pocket hole.  
 Secure parts(5) to part (3) using screw (O)

## Step 07

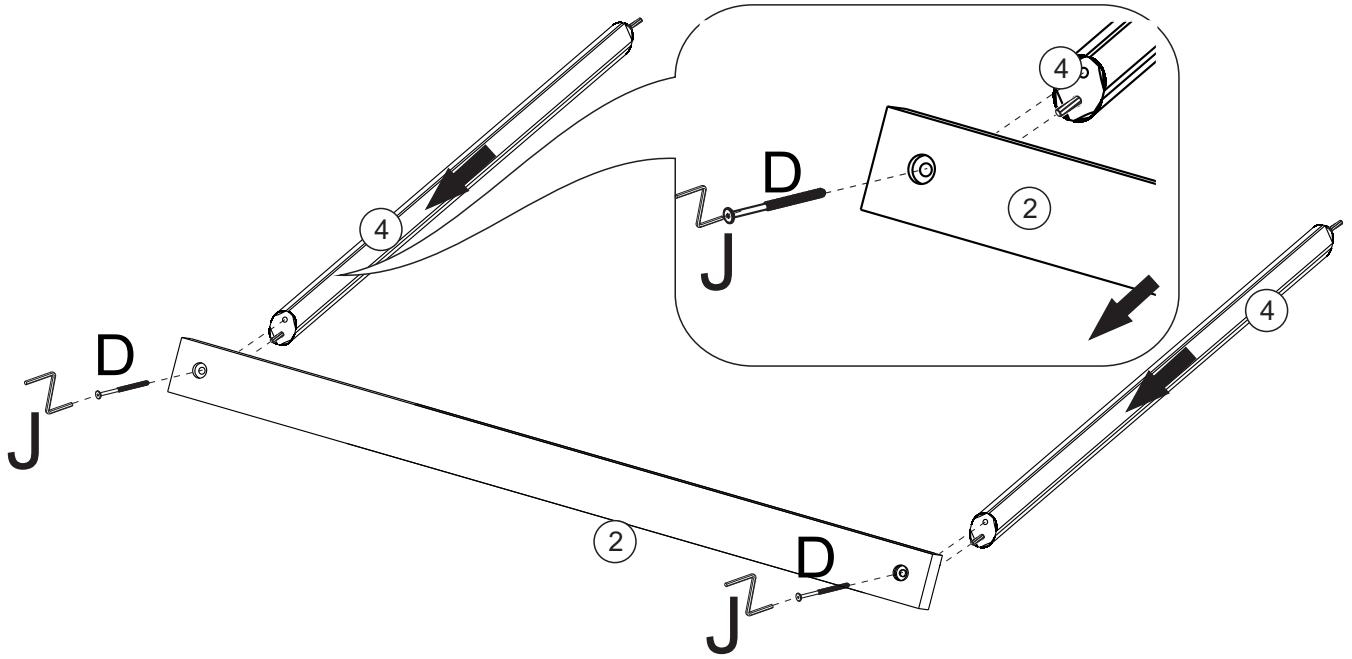

Connect parts (2) to parts (4) using bolt (D) and hex key (J).

## Step 08

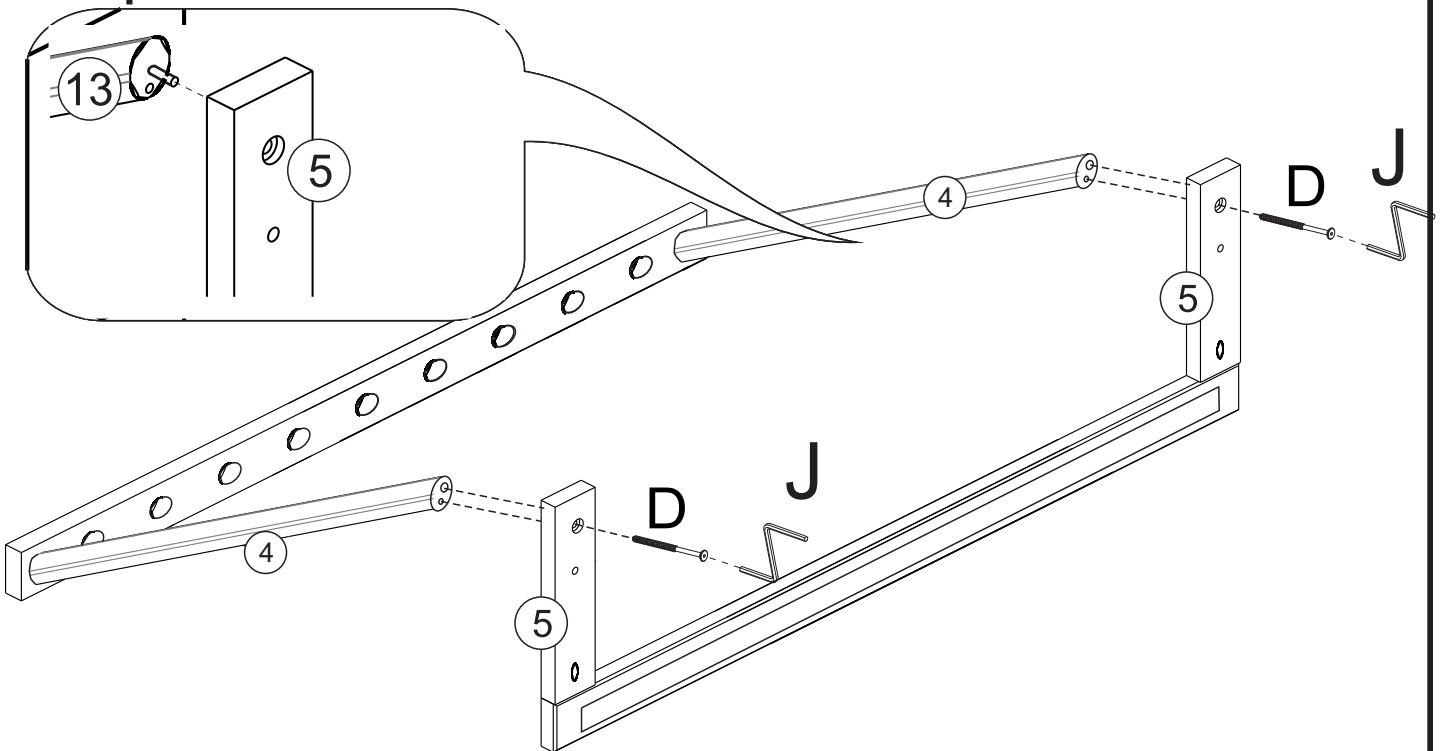

Connect parts (5) to parts (4) using bolt D and hex key (L)



## Step 09

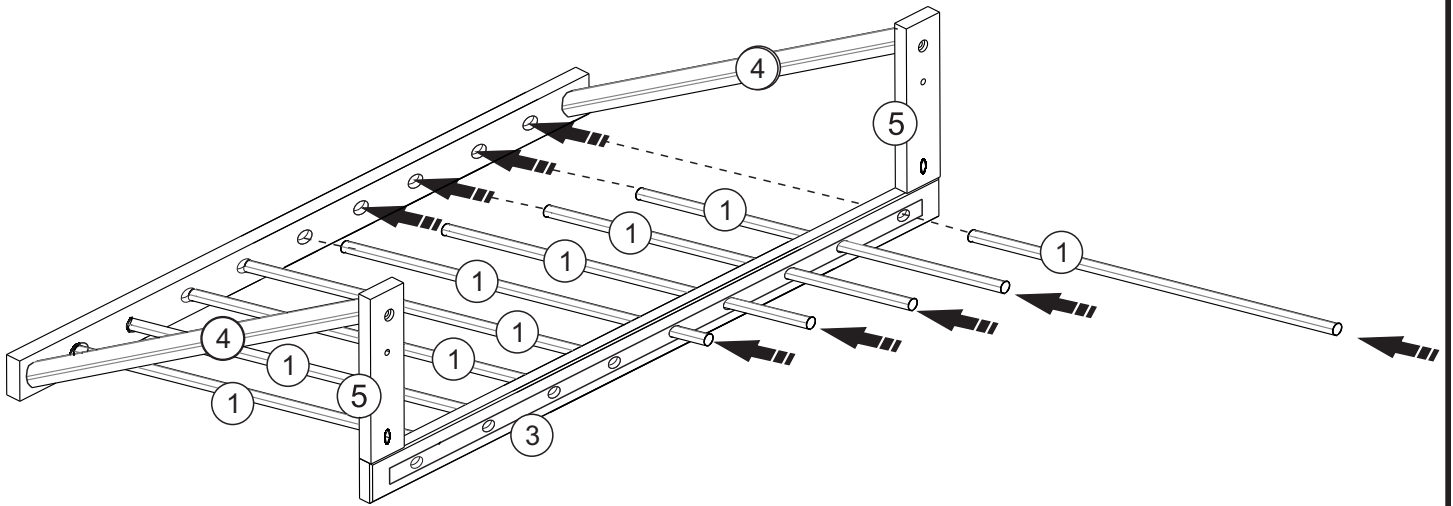

Insert Spindles (1) in holes on part (3)

## Step 10

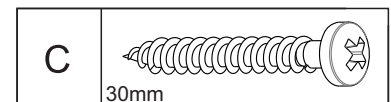
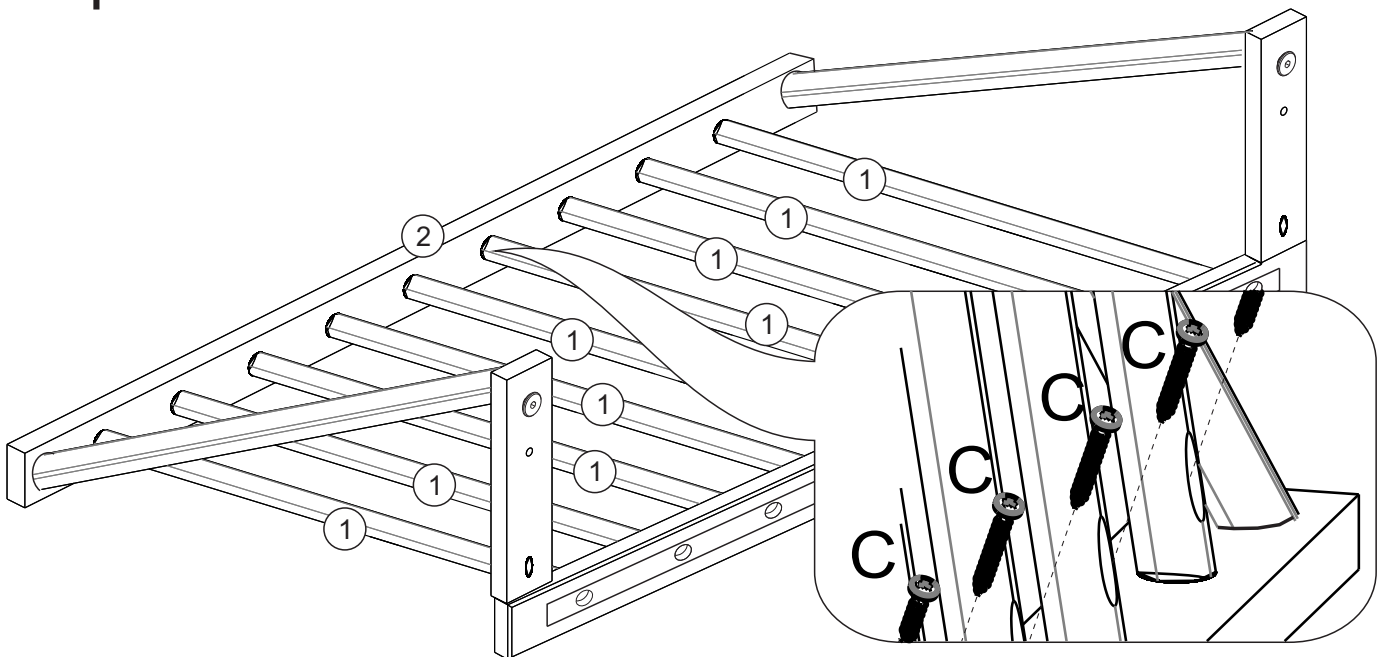

Attach Spindles (1) in the part (2) using screw ( C )

# Step 11

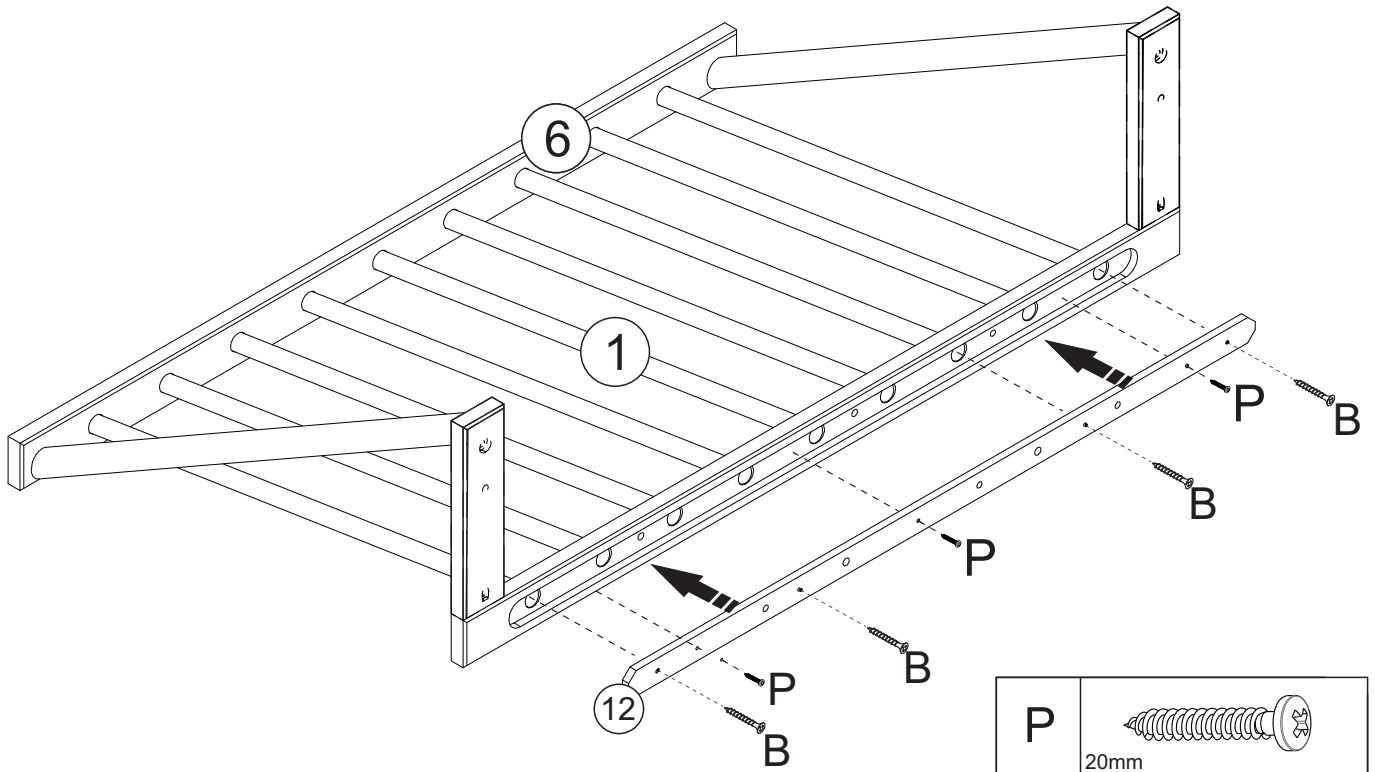

Insert Headboard slat (12) on part (3), with screw ( B),  
secure more 3 Screw ( P) in Spindles ( 1)

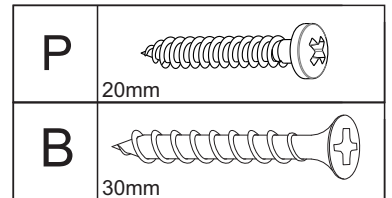

# Step 12

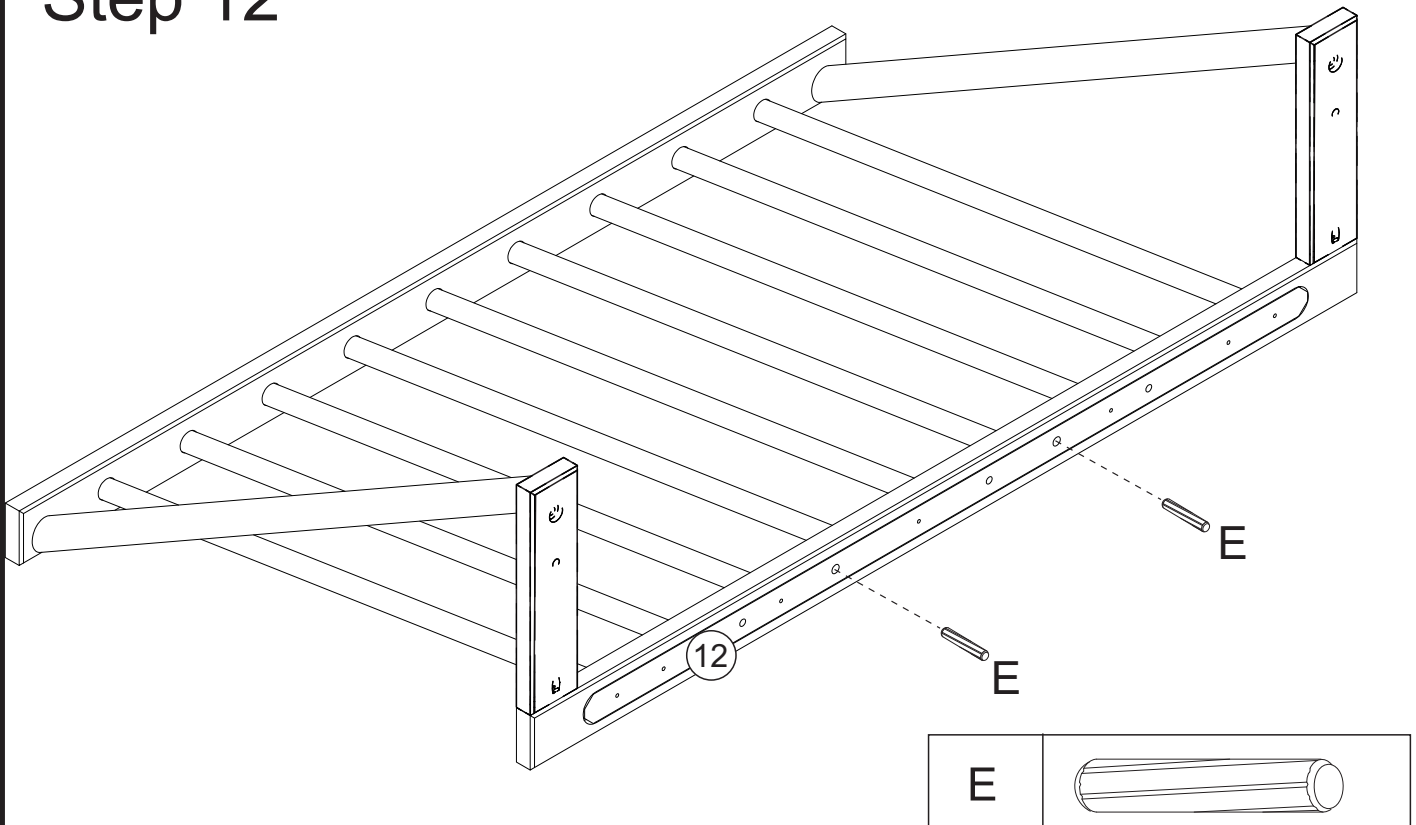

Insert Wood Dowel ( E) in holes to part ( 12)

## Step 13

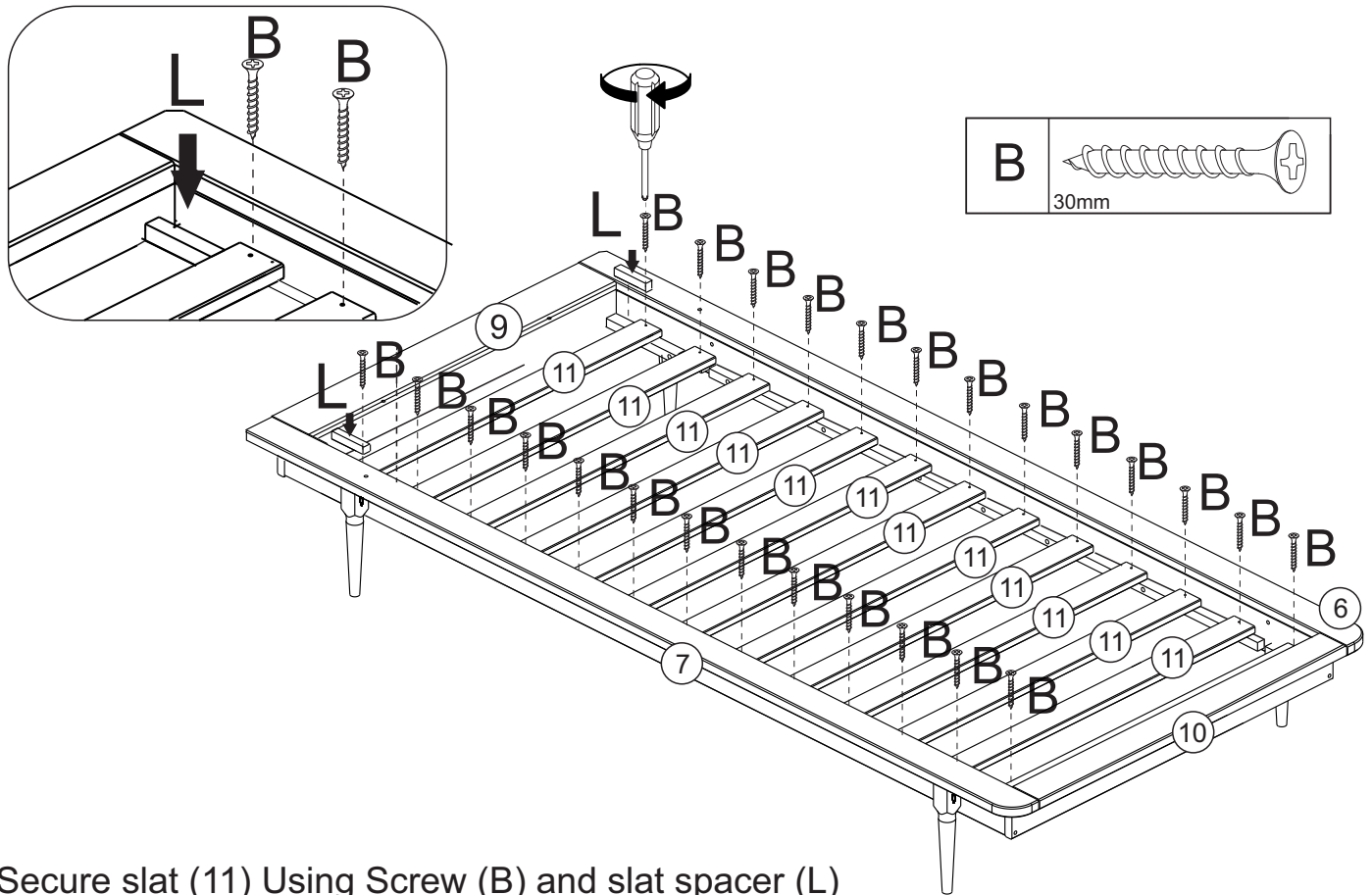

Secure slat (11) Using Screw (B) and slat spacer (L)

## Step 14

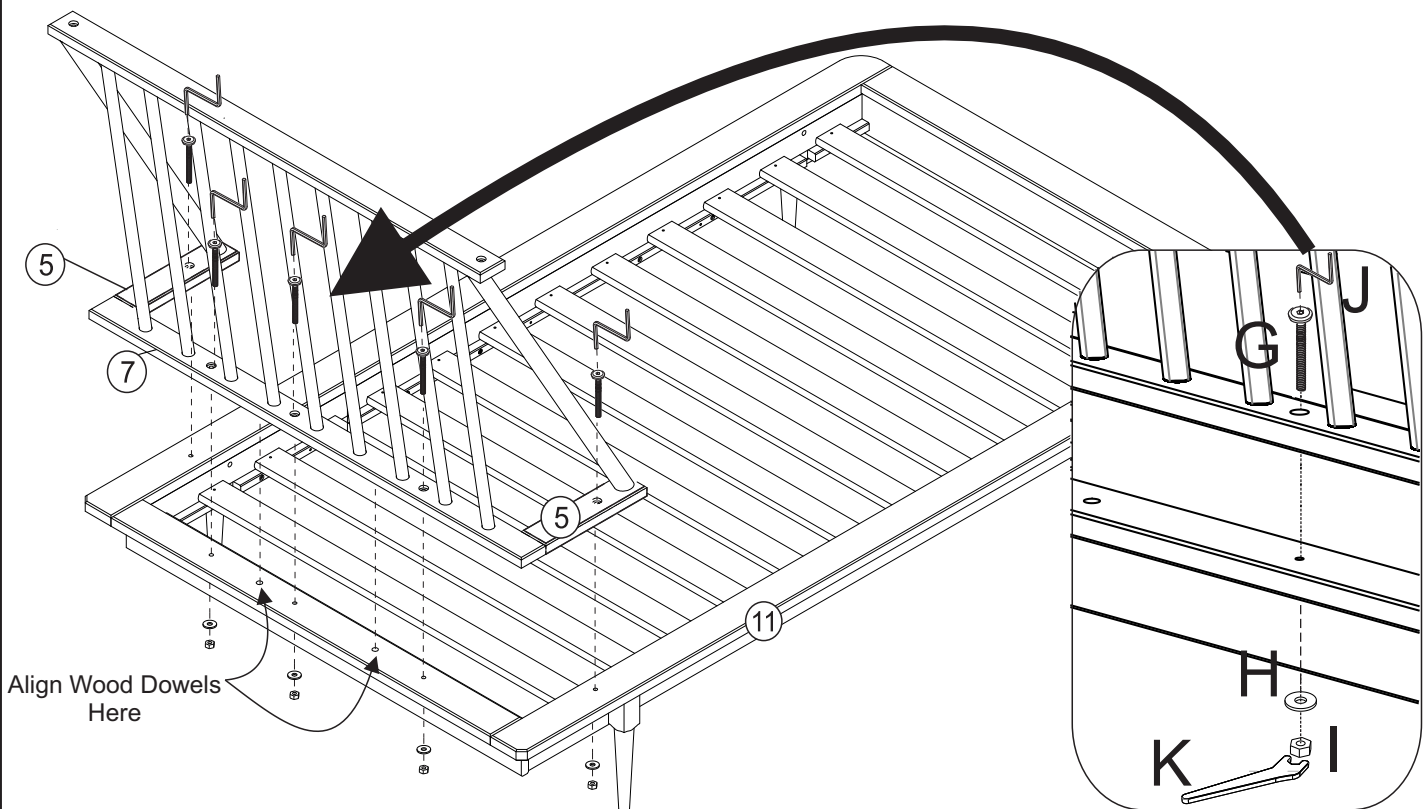

Attach base Headboard (5,3) on holes of the frame (9) using Bolt (G), washer (H), and nut (I) Tighten using both the hex key (J) and wrench (K)



Final Assembly