

Item # : BRSPDB

Assembly Instructions

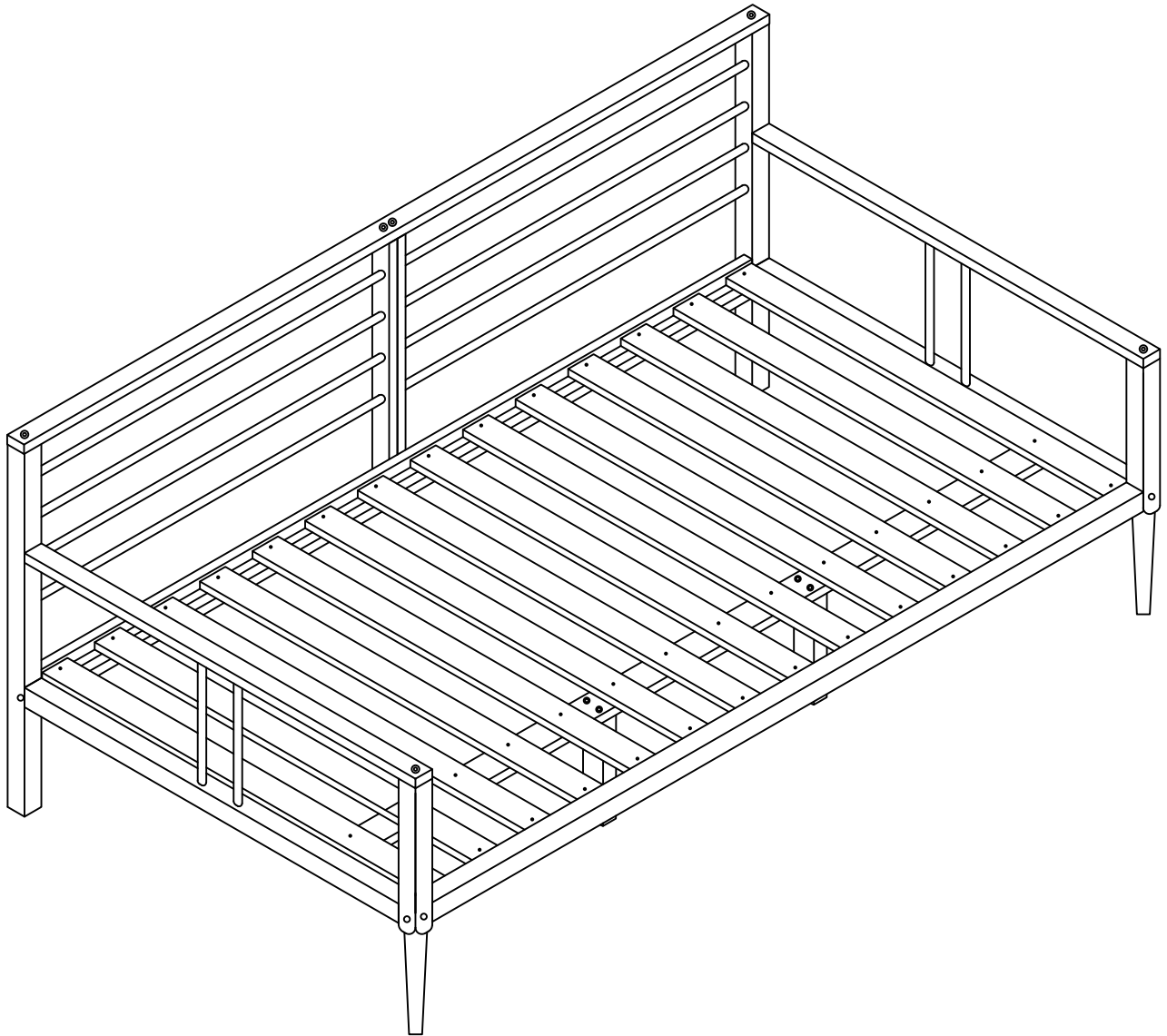

Walker
Edison®

Please visit our website for the most current instructions, assembly tips, report damage,
or request parts. www.walker-edison.com

Revised 09/2019

Copyright © 2018, by Walker Edison Furniture Co., LLC. All rights reserved.

General Assembly Guidelines

- I. Ensure that all parts and hardware are available before beginning assembly.
- II. Follow each step carefully to ensure the proper assembly of this product.
- III. Two people are recommended for ease in the assembly of this product.
- IV. The three main types of hardware used to assemble this product are : wood dowels , screws and bolts.
- V. A Phillips head screwdriver is required for the assembly of this product .

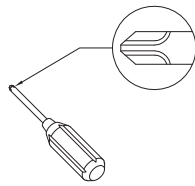



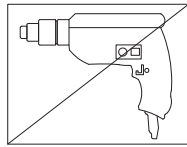

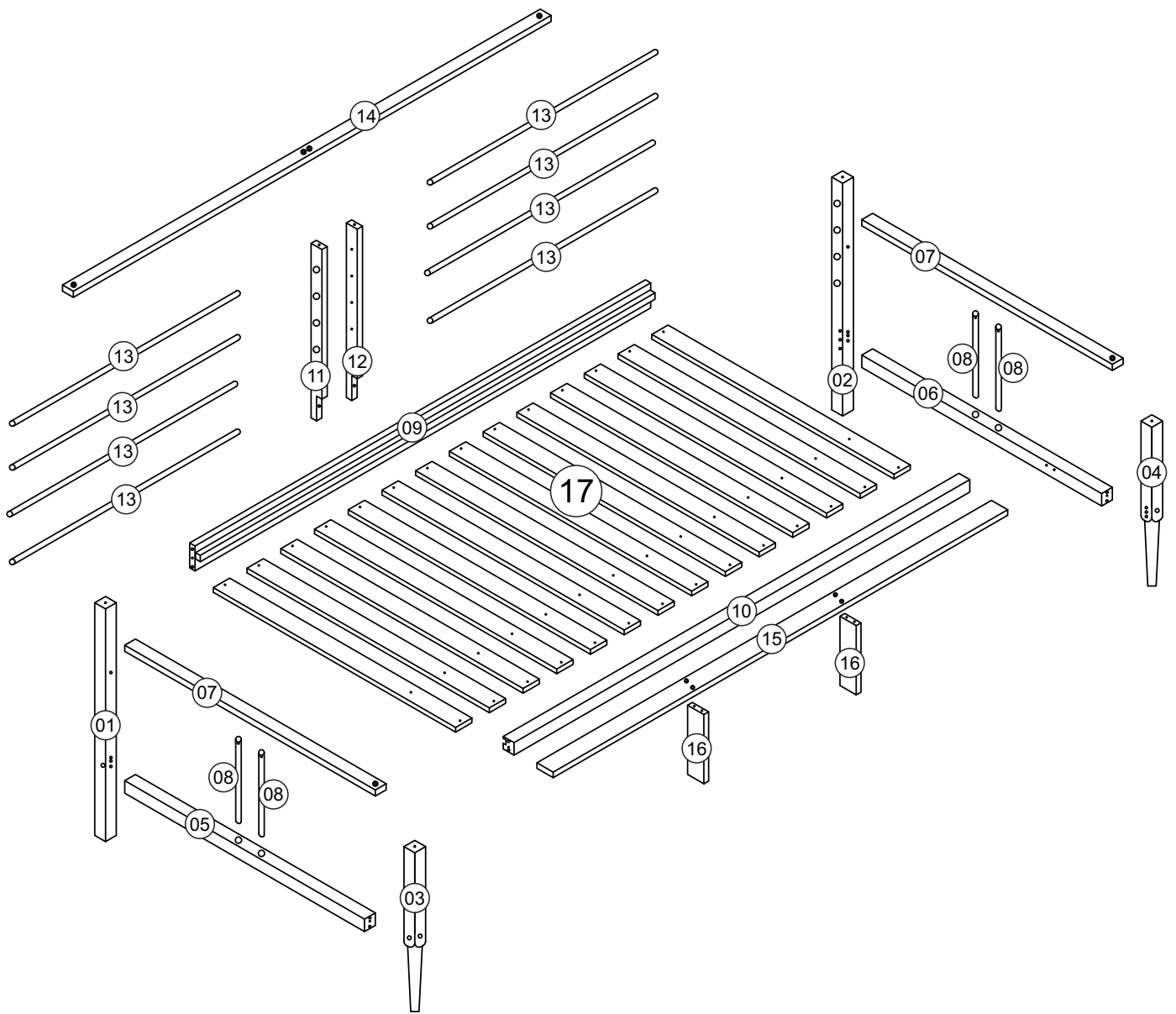

- VI. Power tools should not be used to assemble this product .



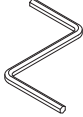
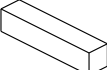

Hardware List

A		Ø08x40 mm	Wood dowel	16 pcs
B		Ø7x60 mm	Bolt	12 pcs
C		7x90 mm Ø	Bolt	10 pcs
D		Ø3.5x20 mm	Screw	08 pcs
E			Metal Plate Connector	02 pcs
F		Ø3.5x35 mm	Screw Hex key	58 pcs
G		4 mm		01 pcs
I			Spacer	02 pcs

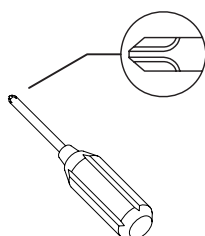
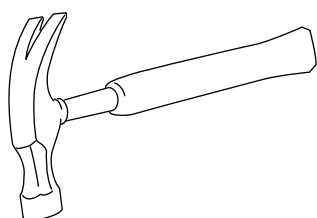

Philips head screwdriver required for assembly
(not included)

Mallet or hammer recommended for assembly
(not included)

*The hardware quantities listed above are required for proper assembly.
Some extra hardware may also have been included.*

Step 1

Insert wooden dowels (A) into rails (9,10), dowels (A) into parts (5,6)

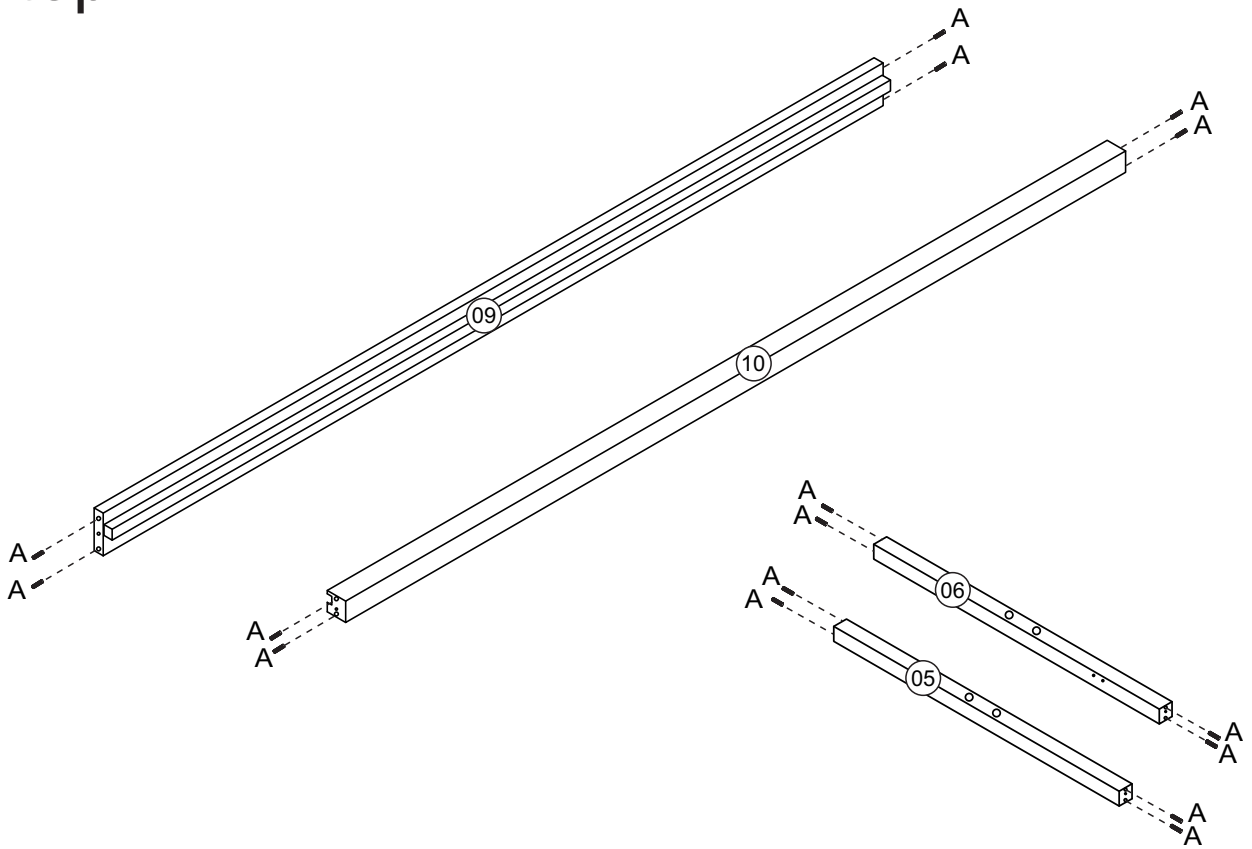

Step 2

Connect parts (01,02,03,04) to parts (05,06) using bolt (C) and hex key (G)

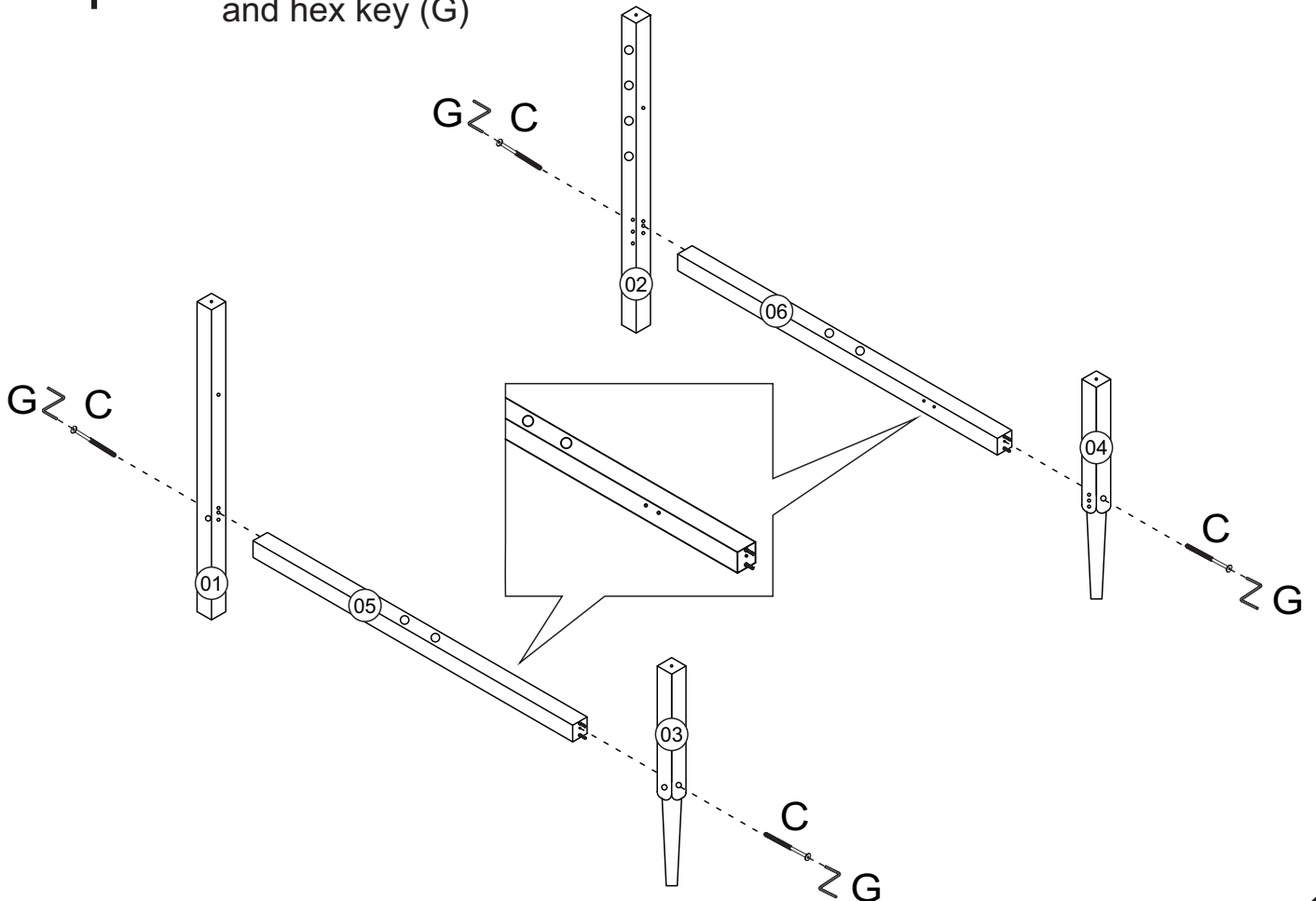

Step 3

Connect parts (08) to parts (05,06) using bolt (F)

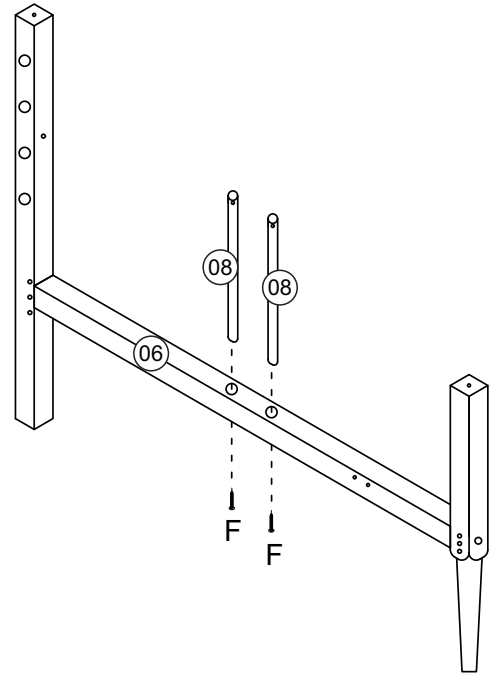
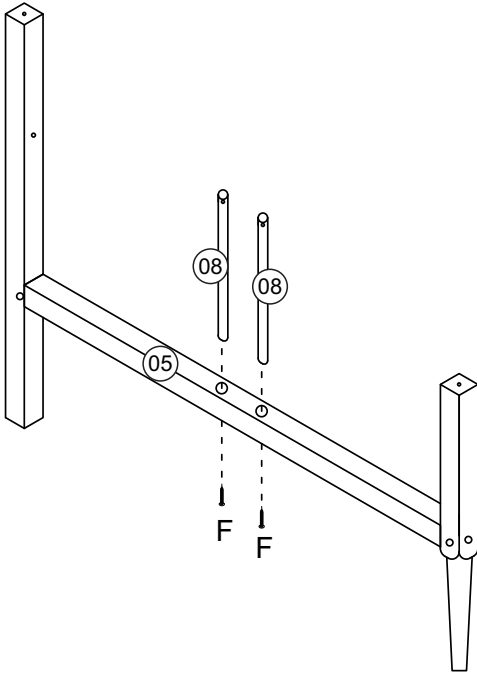

Step 4

Connect parts (01,02) to parts (07) using bolt (C) and hex key (G)

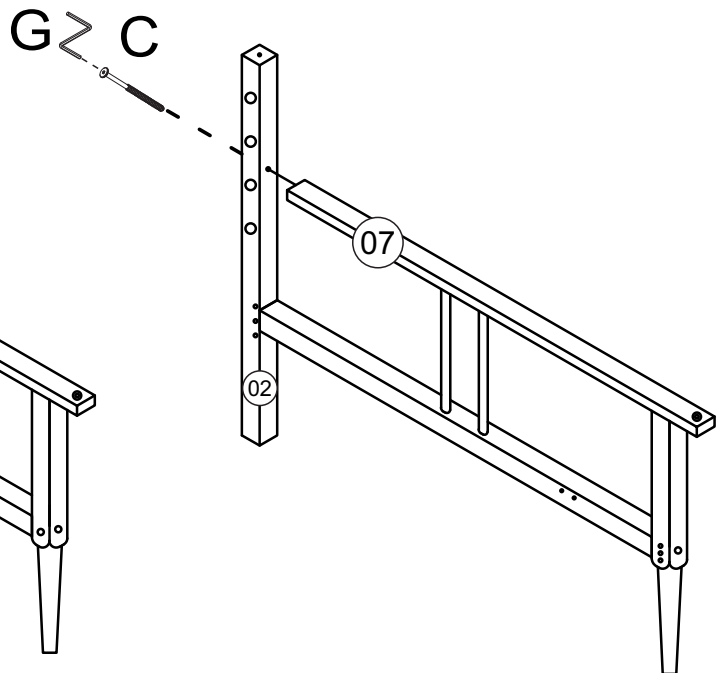
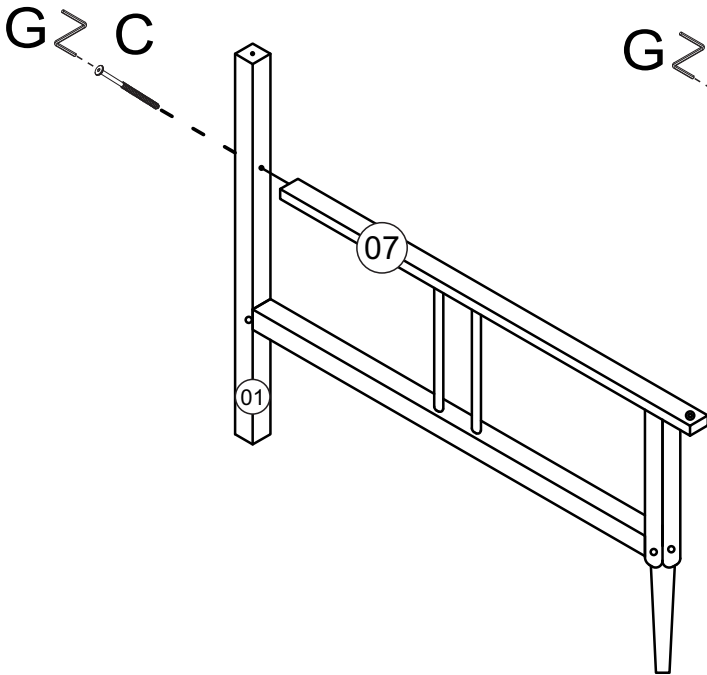

Step 5

Connect parts (07) to parts (03,04) using bolt (B,F) and hex key (G)

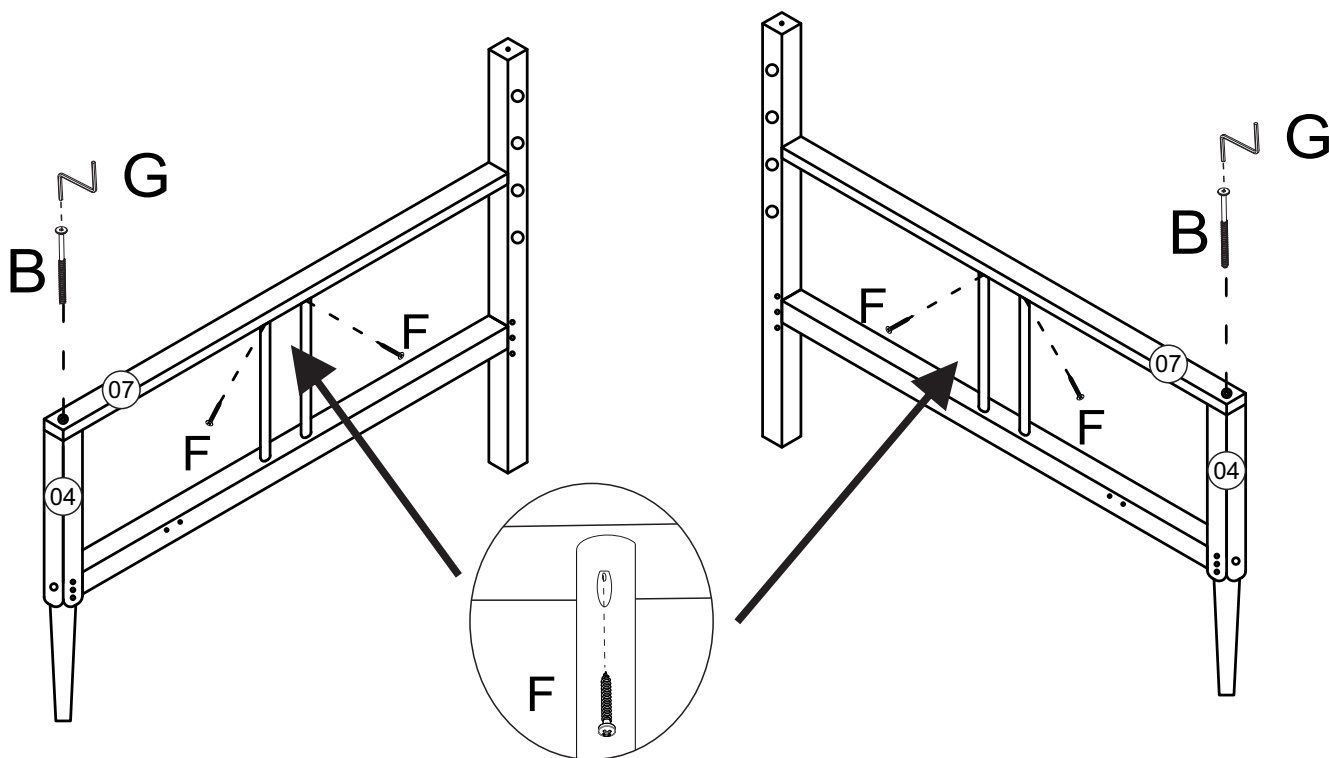

Step 6

Connect parts (09,10) using bolt (C) and hex key (G)

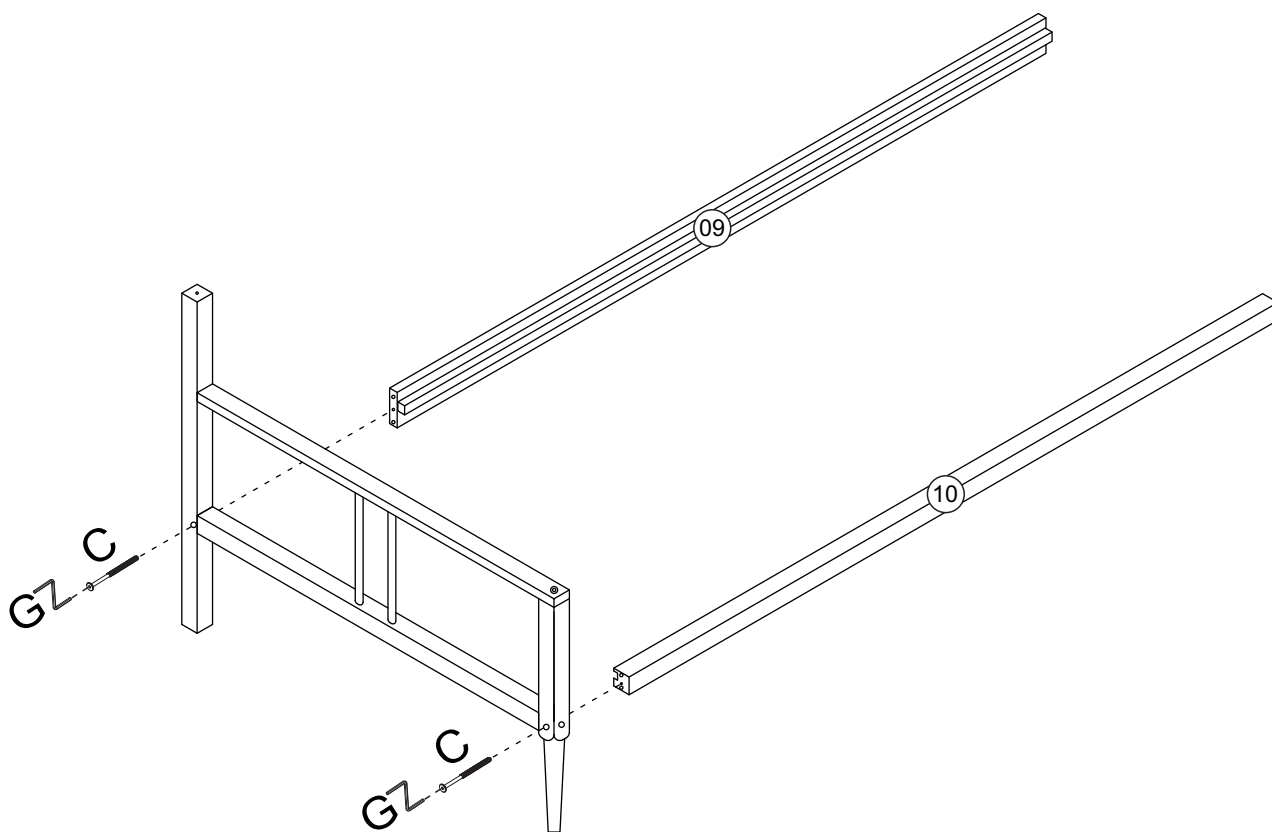

Step 7 Connect parts (09,10,) using bolt (C) and hex key (G)

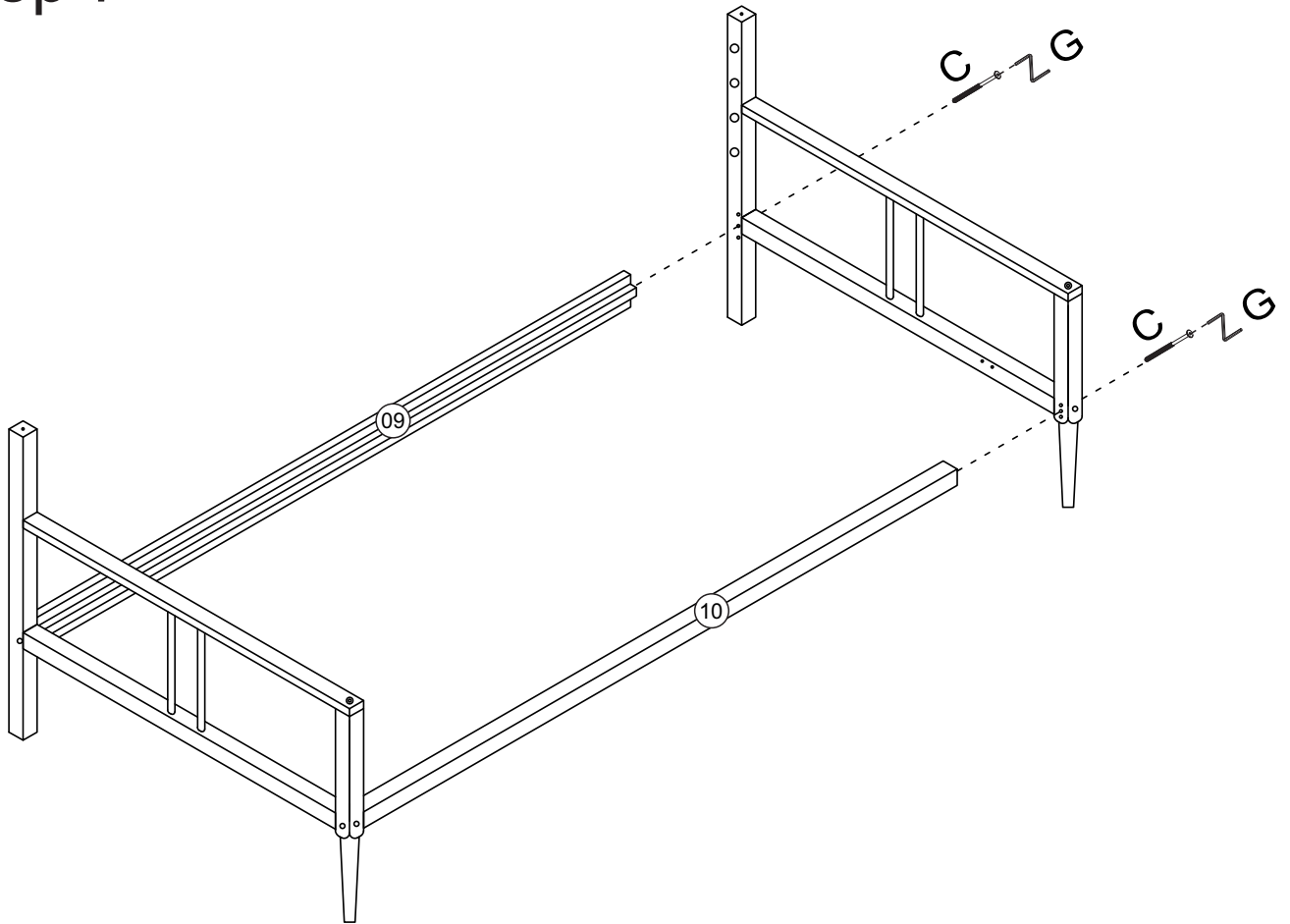

Step 8 Connect parts (13) to parts (11,12) using bolt (F)

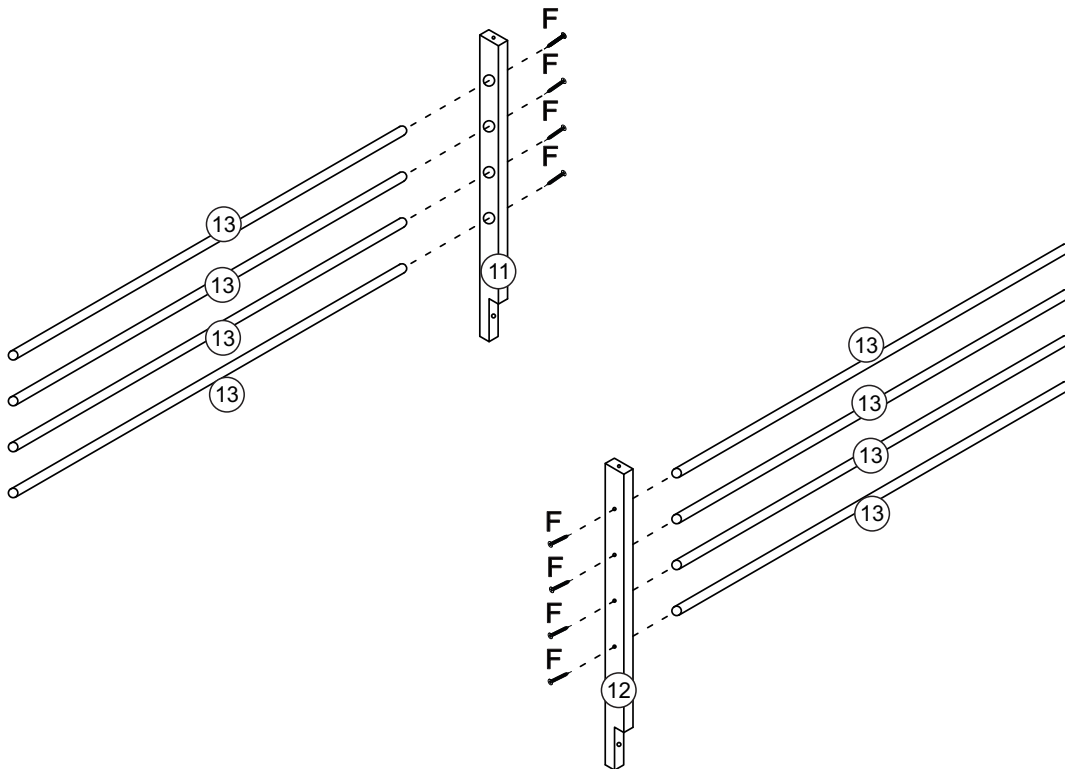

Step 9

Connect parts (13) to parts (02)

Connect parts (12) to parts (09) using bolt (B)

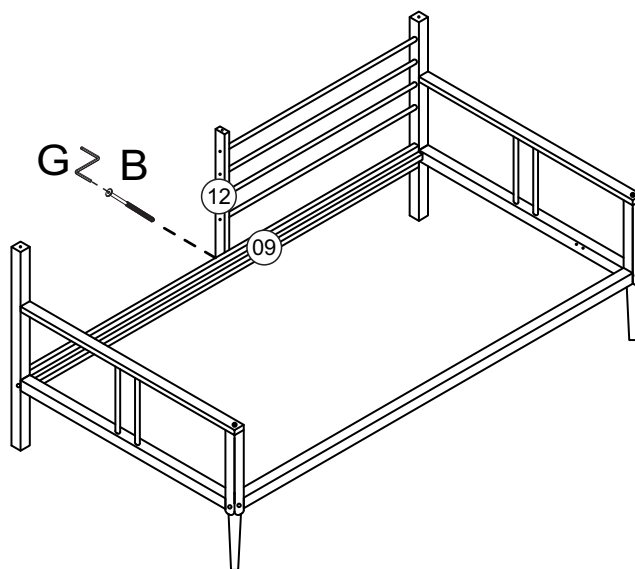
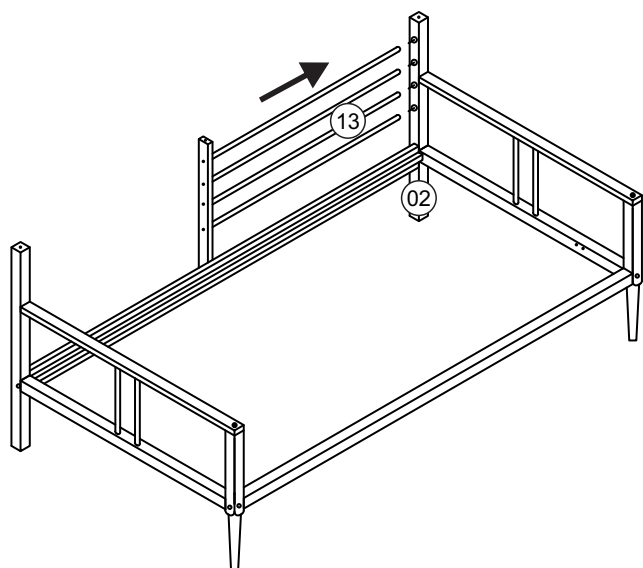

Step 10

Connect parts (13) to parts (01) Connect parts (11) to parts (09) using bolt (B)

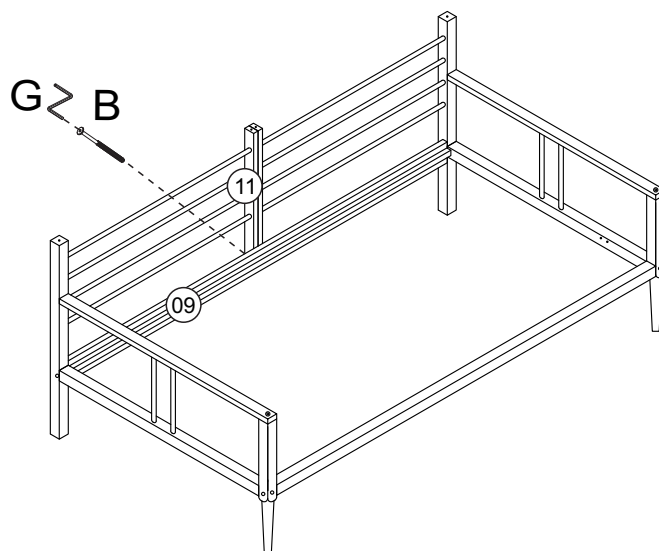
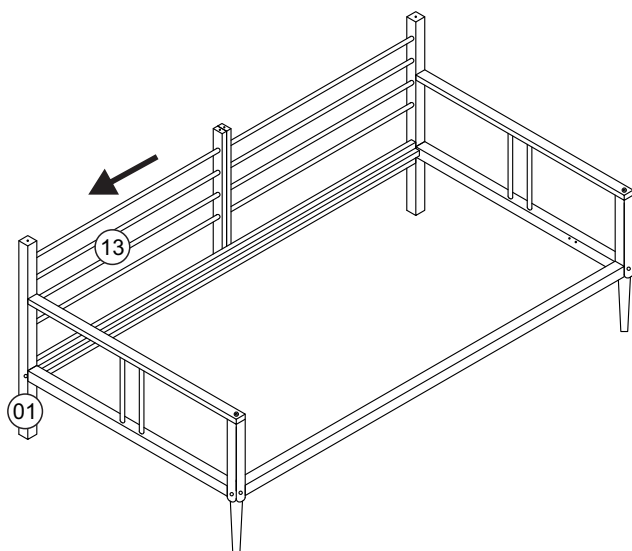

Step 11 Connect parts (14) using bolt (B) and hex key (G)

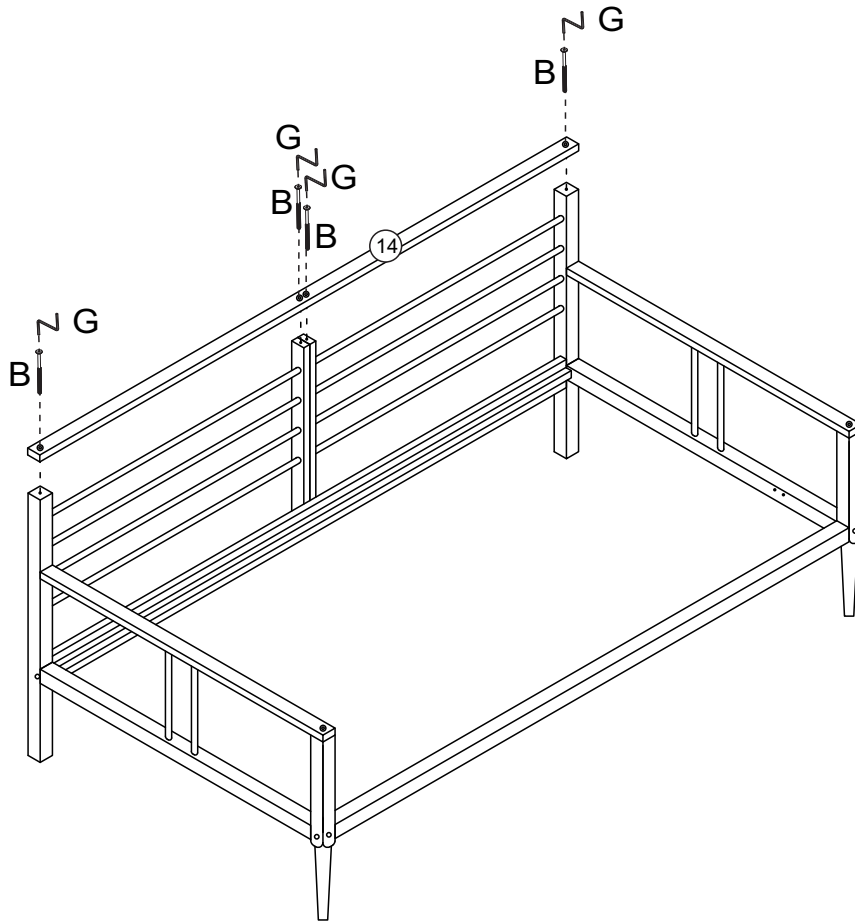

Step 12 Connect parts (15) to parts (16) using bolt (B) and hex Key (L) Connect parts (E) to parts (15) using bolt (D)

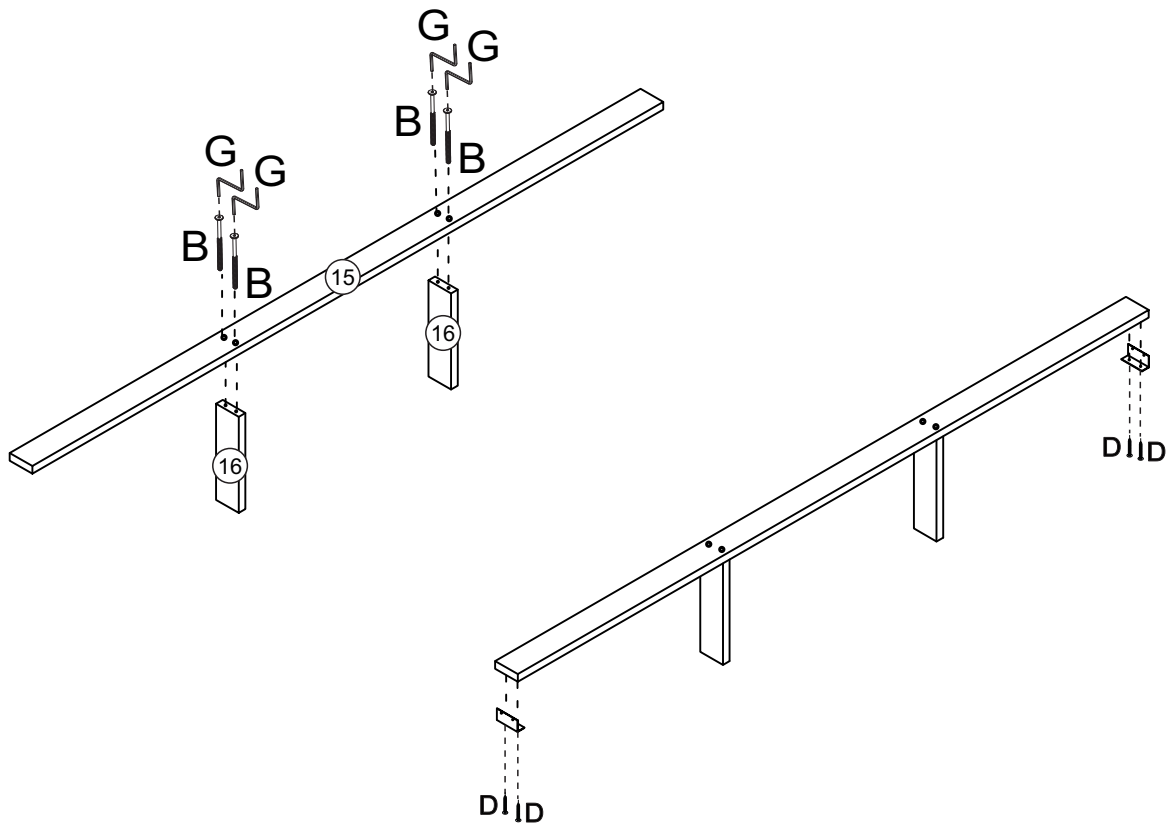

Step 13 Connect parts (15) to parts (05,06) using bolt (D)

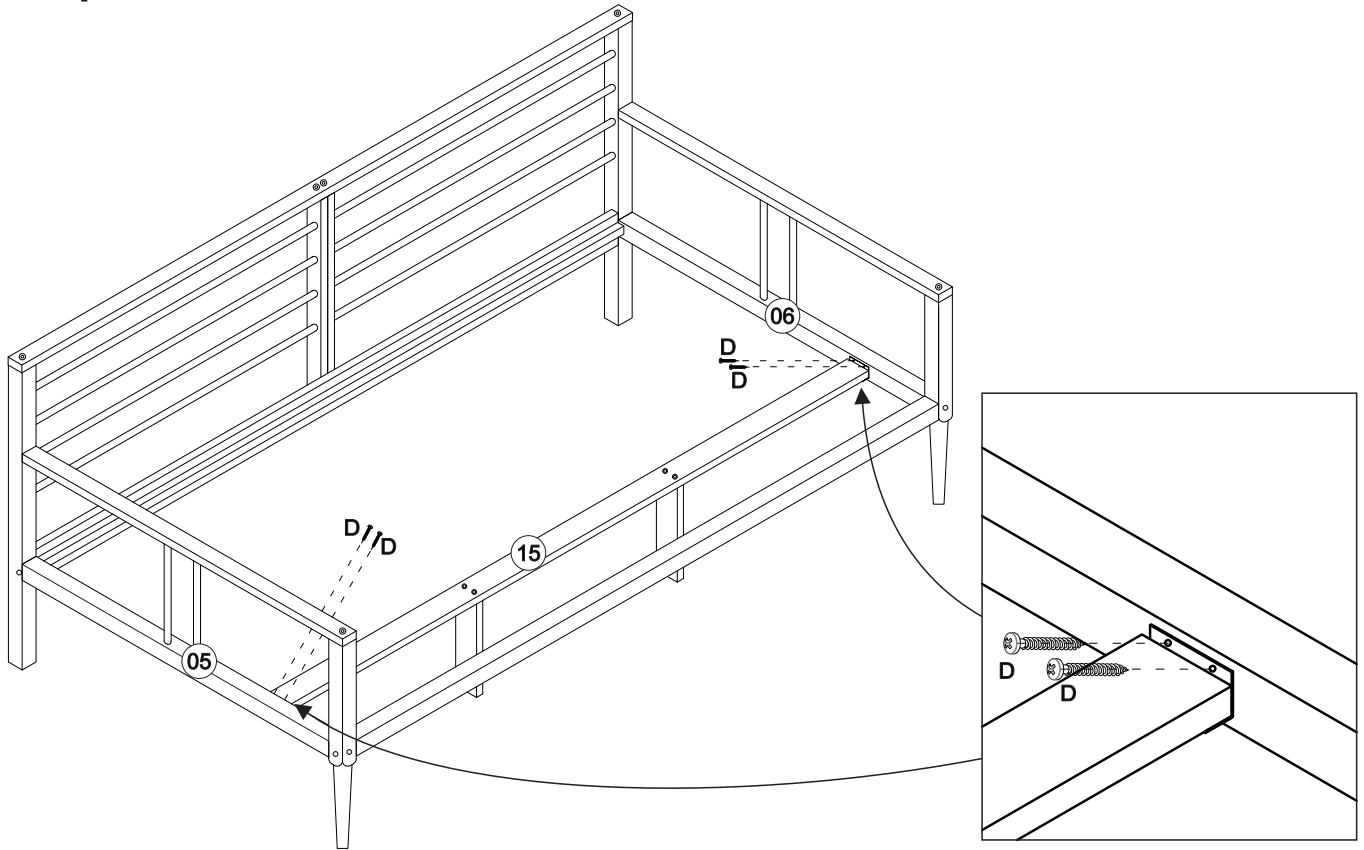

Step 14 Using the spacer provided (I), place the bed slats (2) evenly along the parts (09,10). Connect parts (17) to parts (09,10,15) using bolt (F)

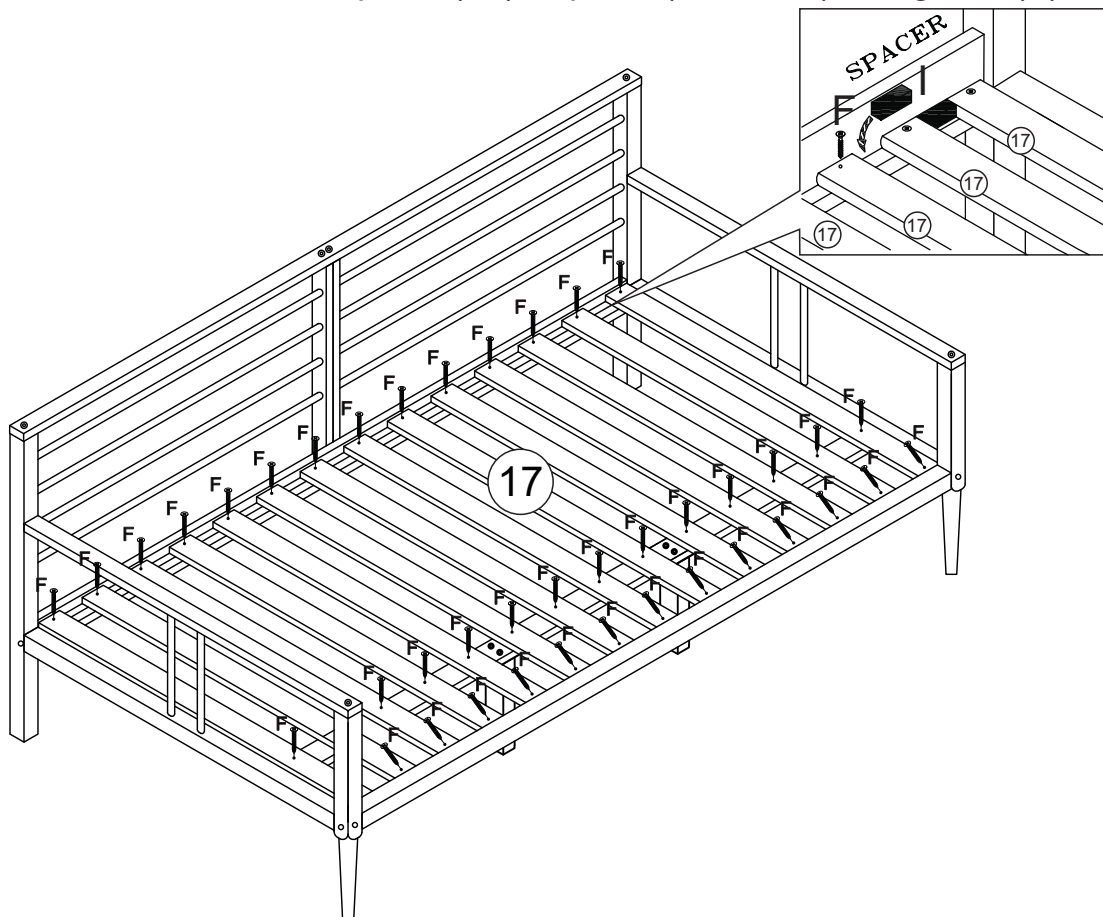

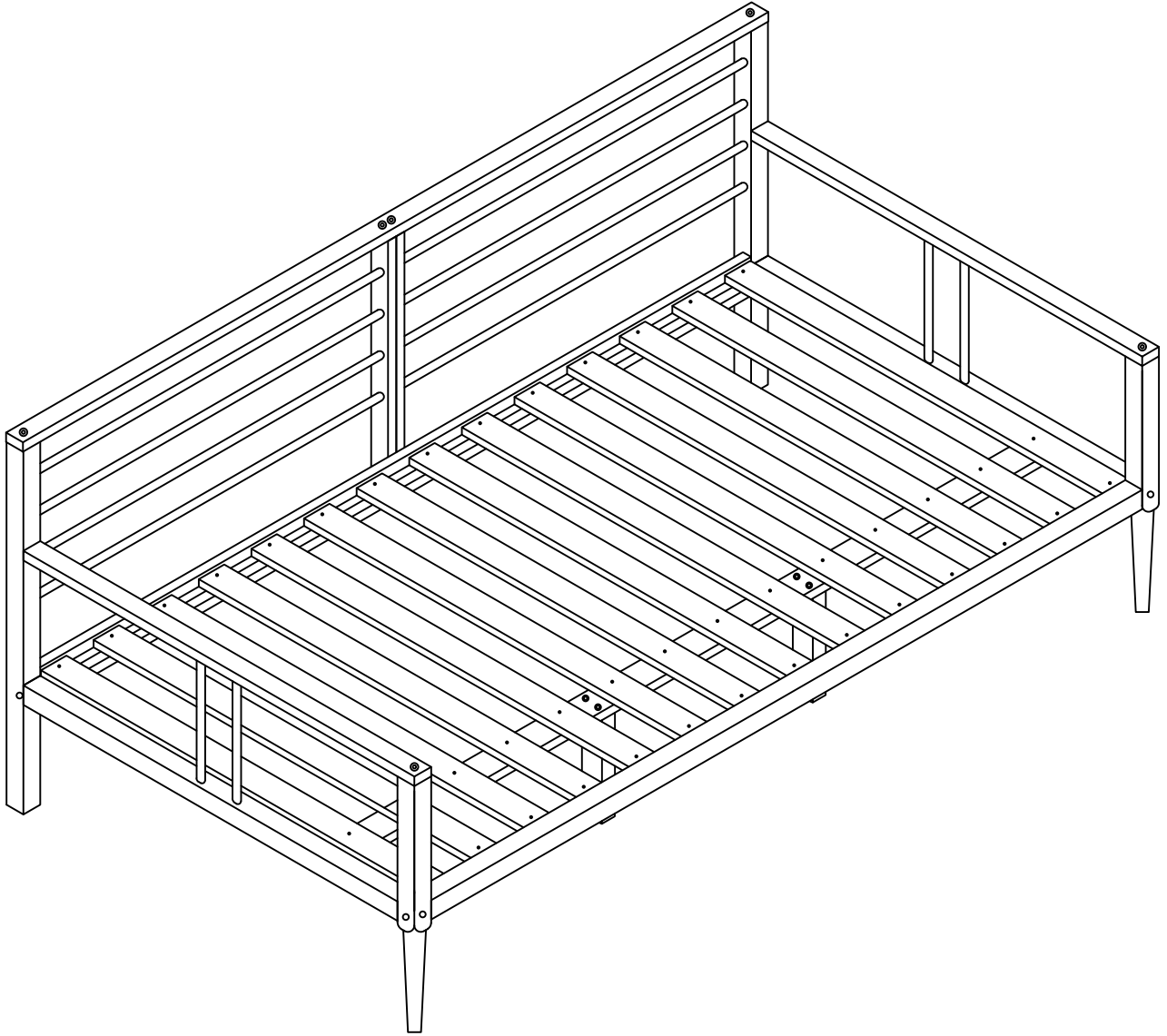

Assembly Complete!