

# Item #: BQATT

## Assembly Instructions

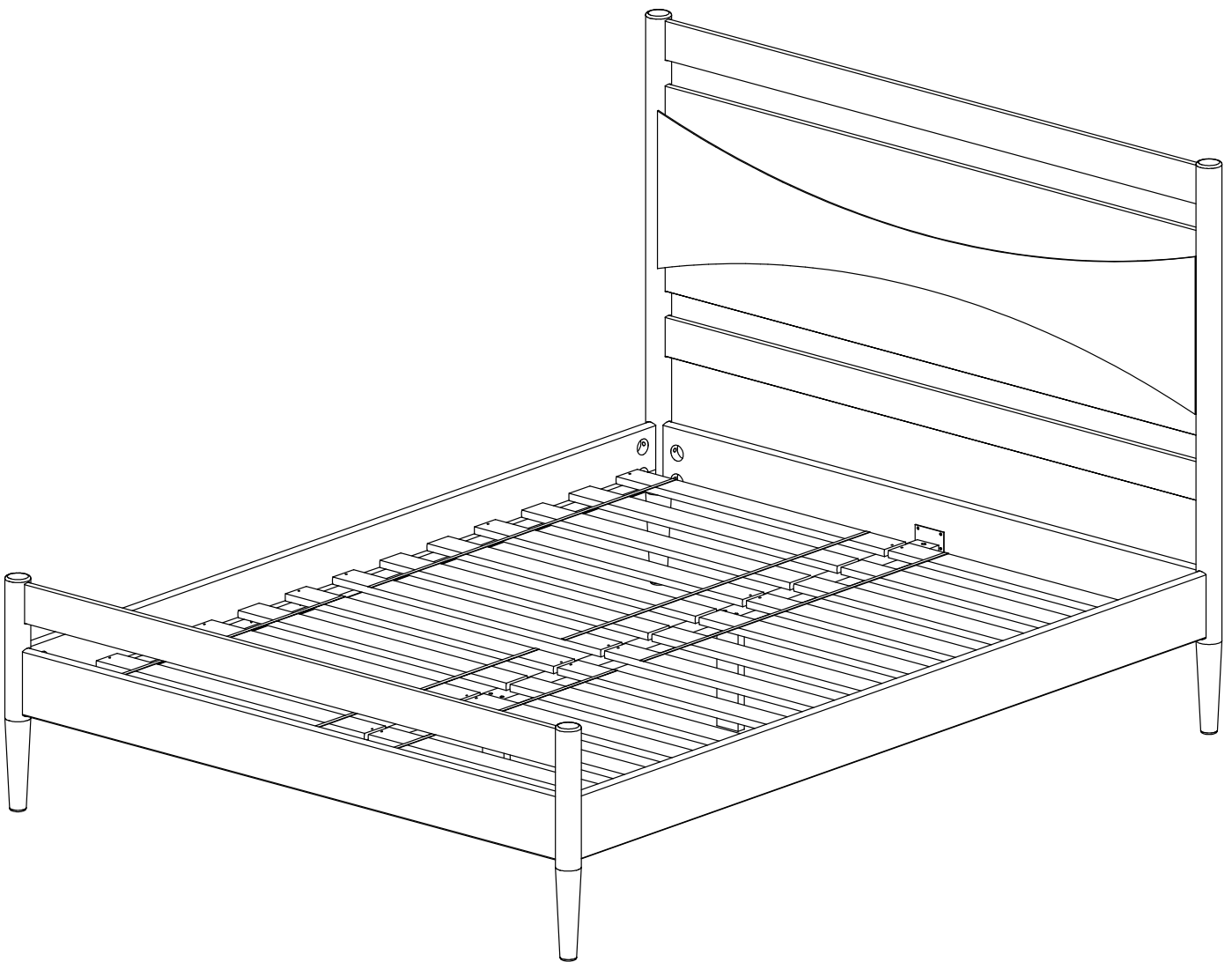

Walker  
Edison®

Please visit our website for the most current instructions, assembly tips, report damage, or request parts. [www.walkerredison.com](http://www.walkerredison.com)

Revised 10/2020

Copyright © 2018, by Walker Edison Furniture Co., LLC. All rights reserved.

# General Assembly Guidelines

- I. Ensure that all parts and hardware are available before beginning assembly.
- II. Follow each step carefully to ensure the proper assembly of this product.
- III. Two people are recommended for ease in the assembly of this product.
- IV. The three main types of hardware used to assemble this product are : wood dowels , screws and bolts.
- V. A Phillips head screwdriver is required for the assembly of this product .

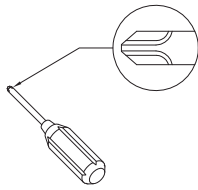

- VI. Power tools should not be used to assemble this product .

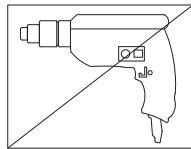

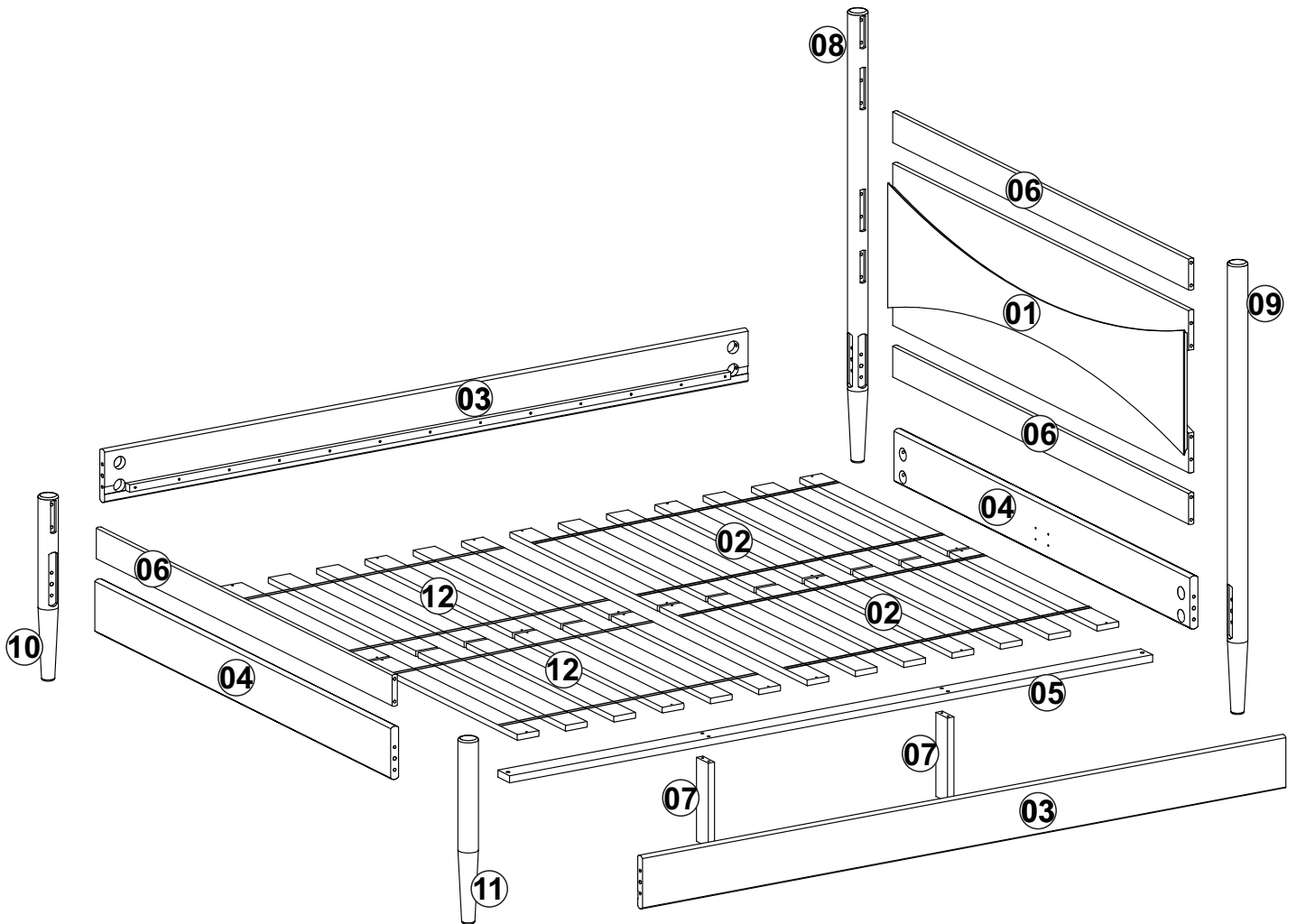

## Parts List

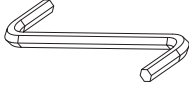
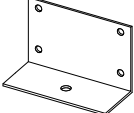

- Part 1: Headboard Panel
- Part 2: Slat Set (7 slats)
- Part 3: Side Rail
- Part 4: Down Rail
- Part 5: Cross Bar
- Part 6: Up Rail
- Part 7: Legs
- Part 8: Headboard Left Feet
- Part 9: Headboard Right Feet
- Part 10: Footboard Left Feet
- Part 11: Footboard Right Feet
- Part 12: Slat Set (6 slats)

# Hardware List

A		Ø10x40 mm	Wood dowel	08 pçs
B		Ø08x40 mm	Wood dowel	16 pçs
C		Ø1/4"x70 mm	Headless bolt	20 pçs
D			Washer	20 pçs
E			Nut	22 pçs
F			Hex Key	01 pçs
G			Spanner	01 pçs
H		Ø3,5x35mm	Screw	24 pçs
I		Ø4,0x16mm	Screw	08 pçs
J			Metal Support	02 pçs
K		Ø7,0x50mm	Bolt	04 pçs
L		Ø1/4"x40mm	Bolt	02 pçs

**Ruler-** Use this ruler to help correctly identify the screws

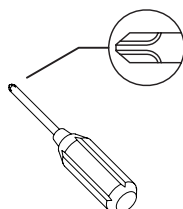

Philips head screwdriver required for assembly  
(not included)

*The hardware quantities listed above are required for proper assembly.  
Some extra hardware may also have been included.*

# Step 1

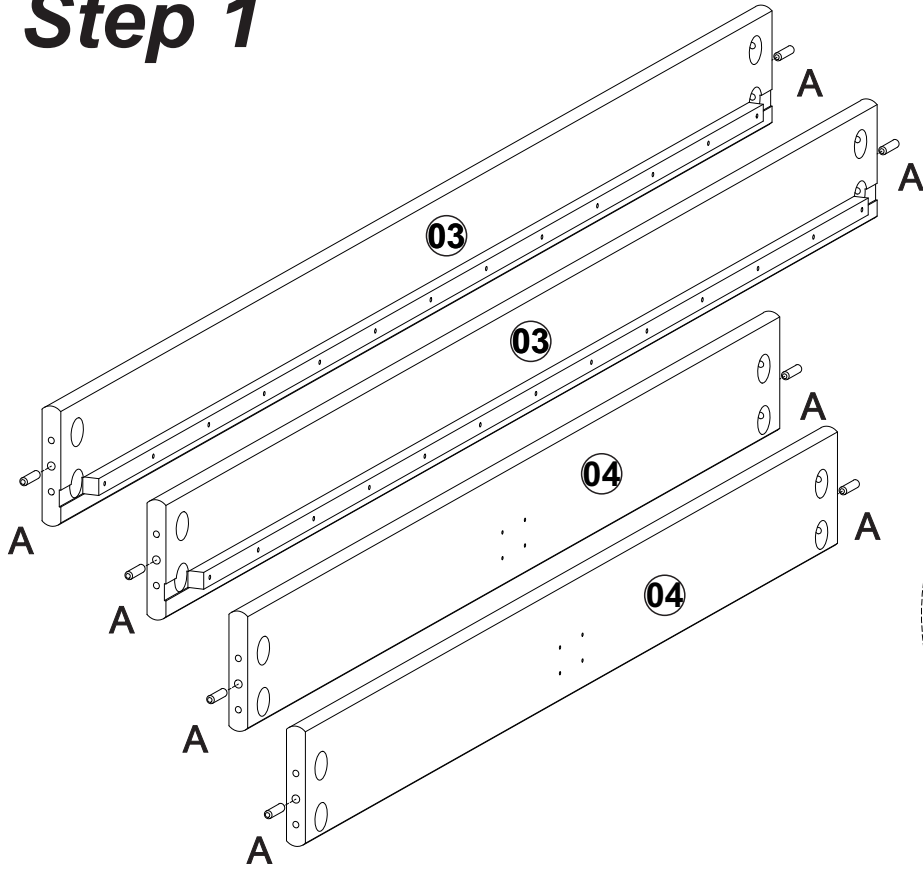

A

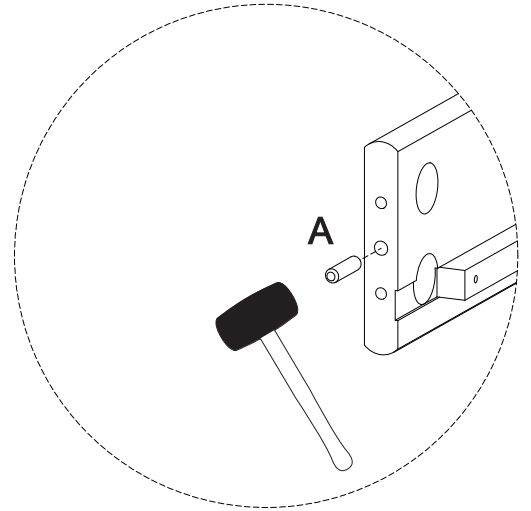

Insert wood dowels (A) into parts (03 and 04).

# Step 2

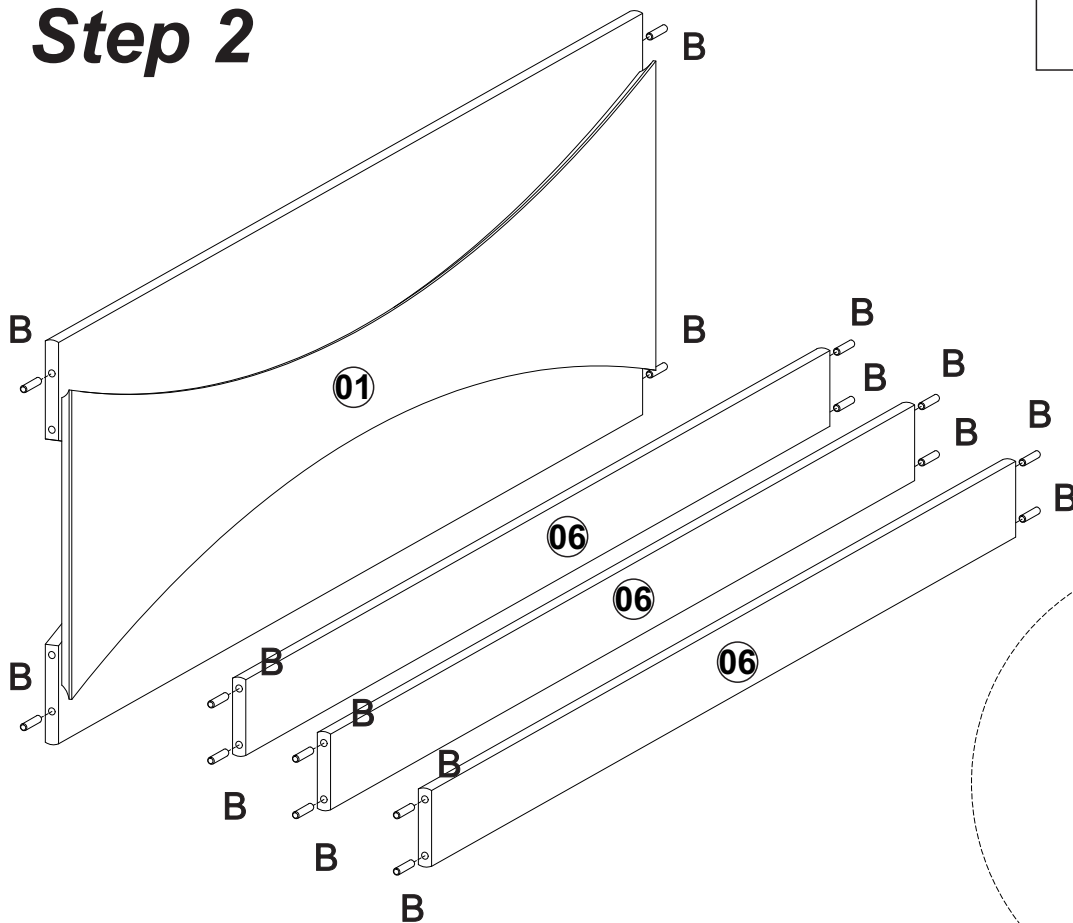

B

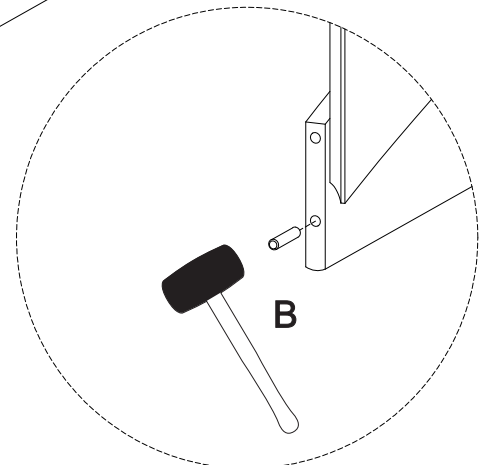
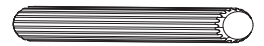

Insert wood dowels (B) into parts (01 and 06).

# Step 3

C

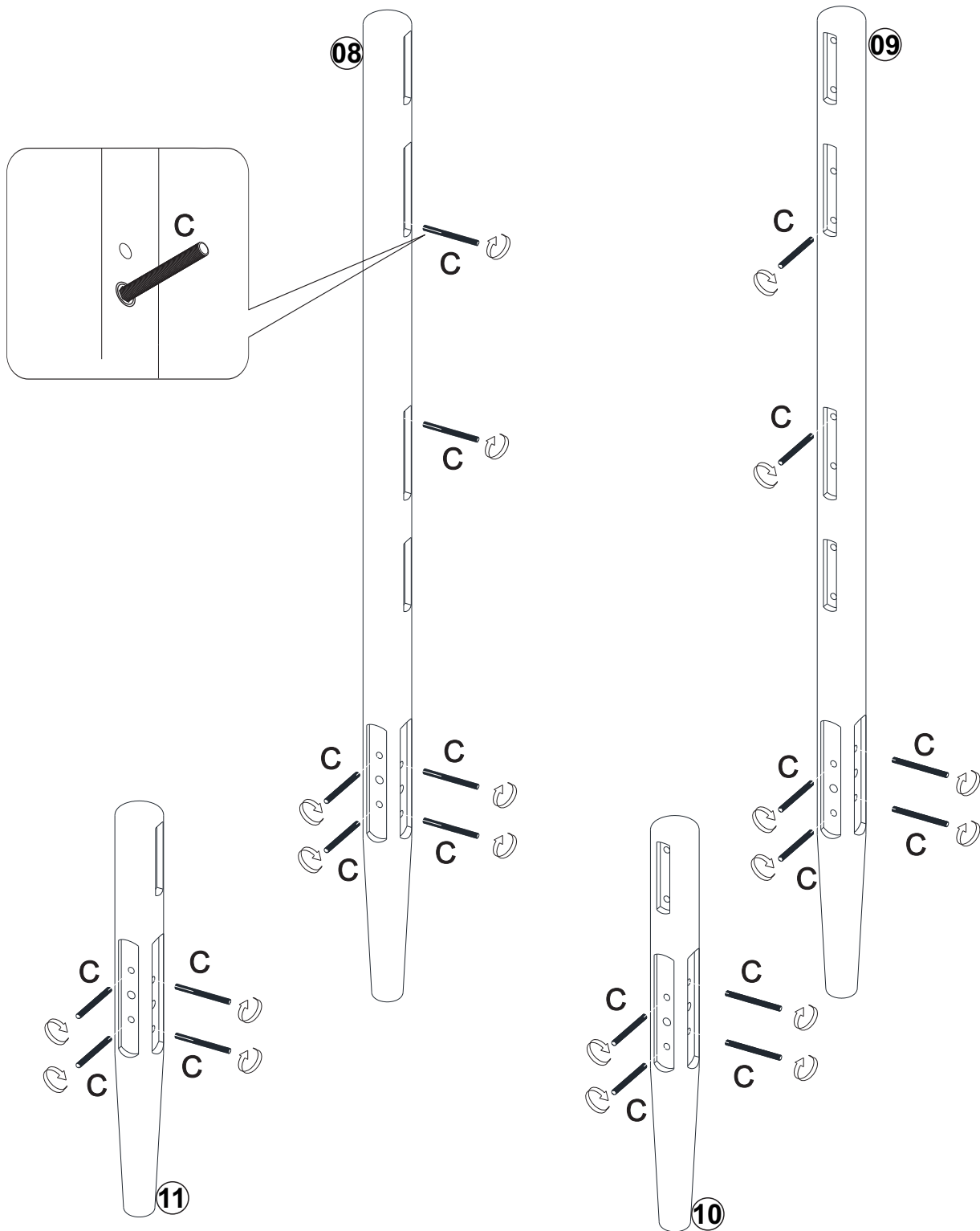

Insert Headless (C) into parts (08,09,10 and 11).

## Step 4

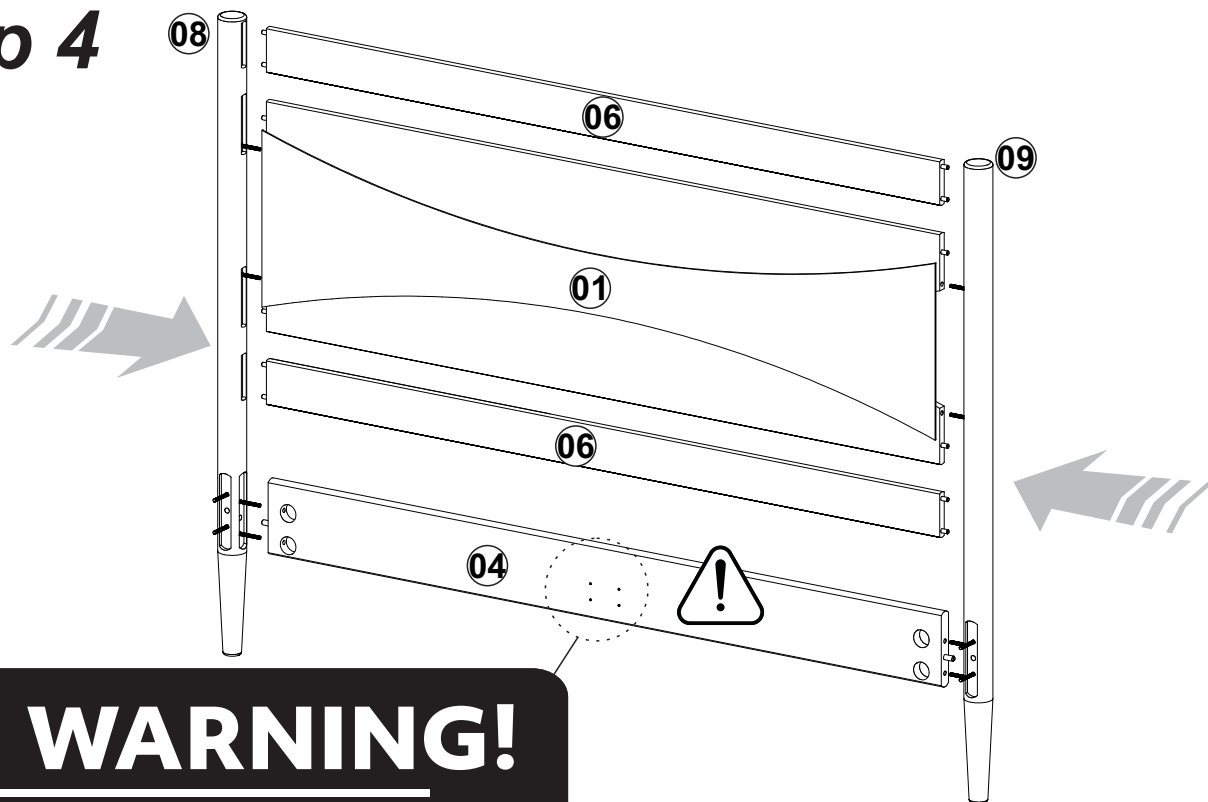

**WARNING!**

PLEASE, Check the holes position  
**CAREFULLY**

Assemble the parts 06, 01 and 04 on the feet 08 and 09.

## Step 5

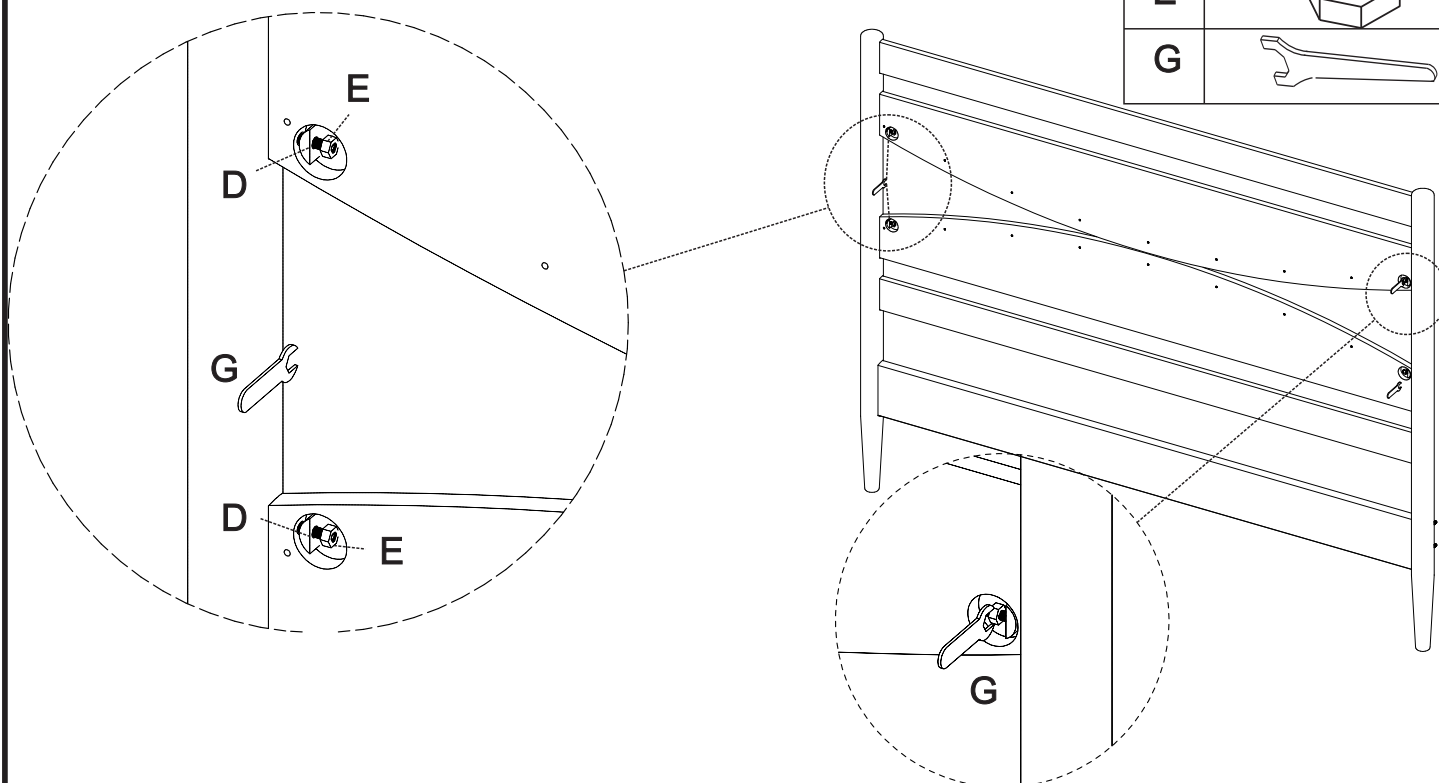

Insert washer (D) and nut (E) as in the picture. After use Spanner (G) to tighten. Repeat the same process at both sides.

## Step 6

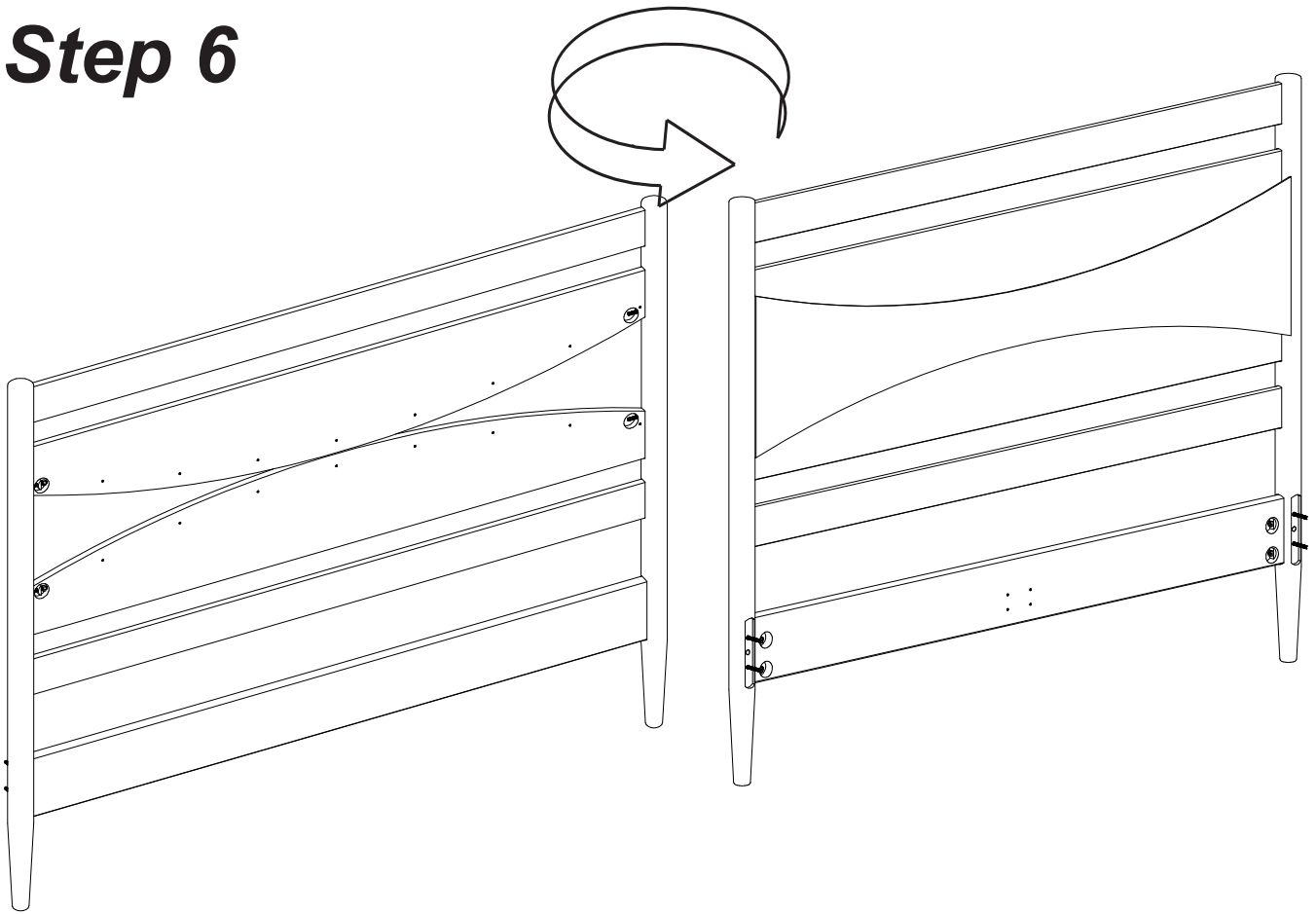

Rotate the Headboard 180 degrees.

## Step 7

D	
E	
G	

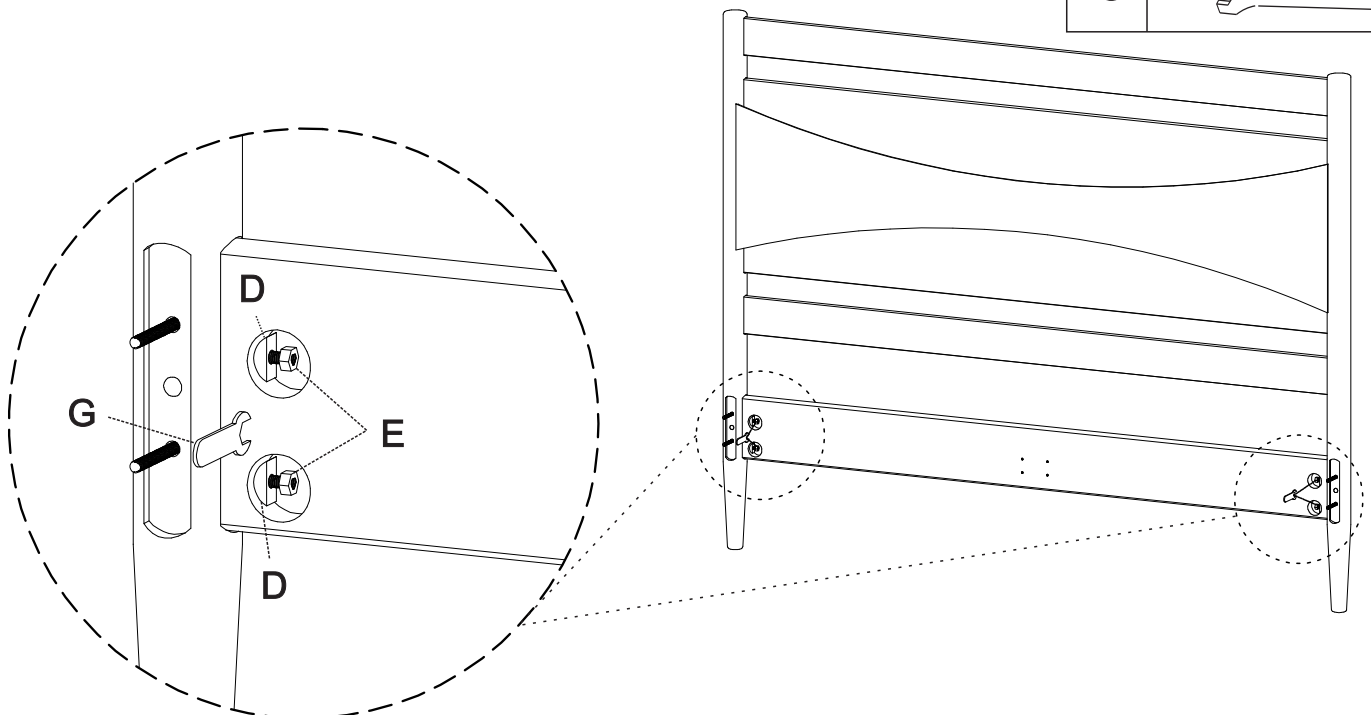

Insert washer (D) and nut (E) as in the picture. After use Spanner (G) to tighten. Repeat the same process at both sides.



## Step 8

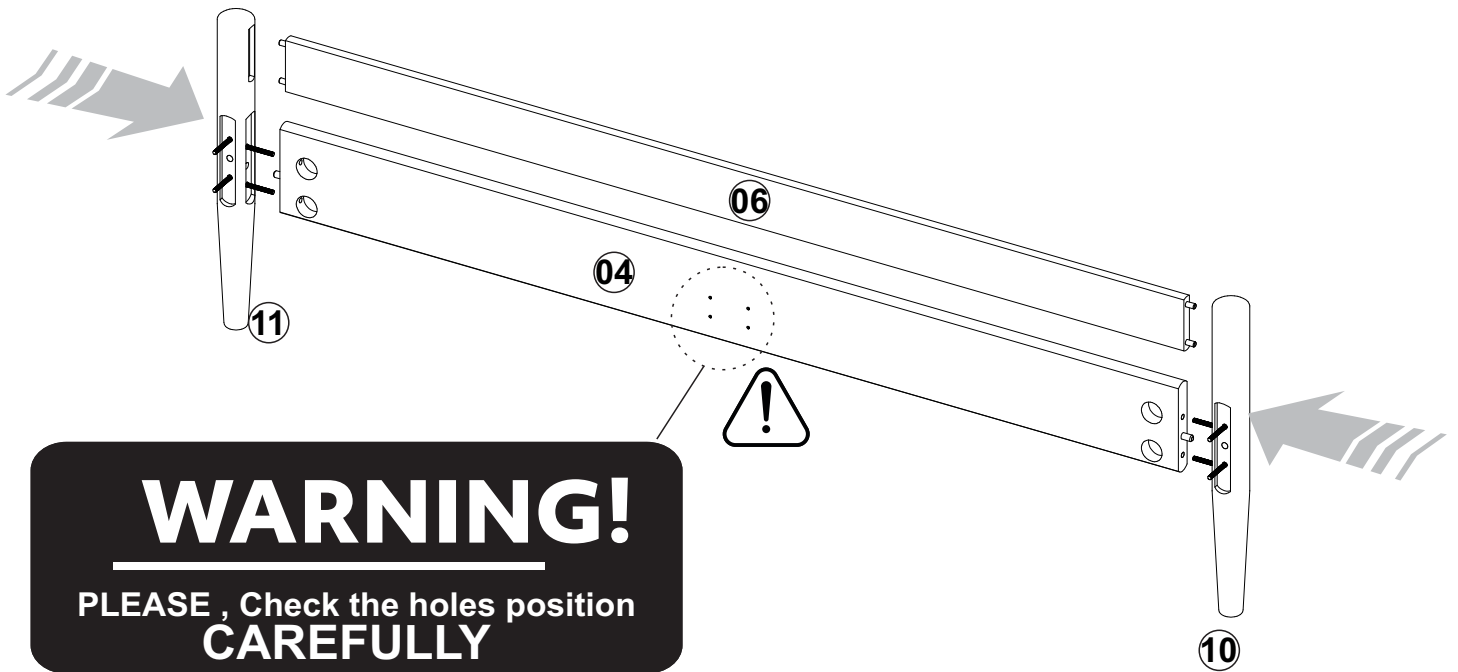

Assemble the parts 06 and 04 on the feet 10 and 11.

## Step 9

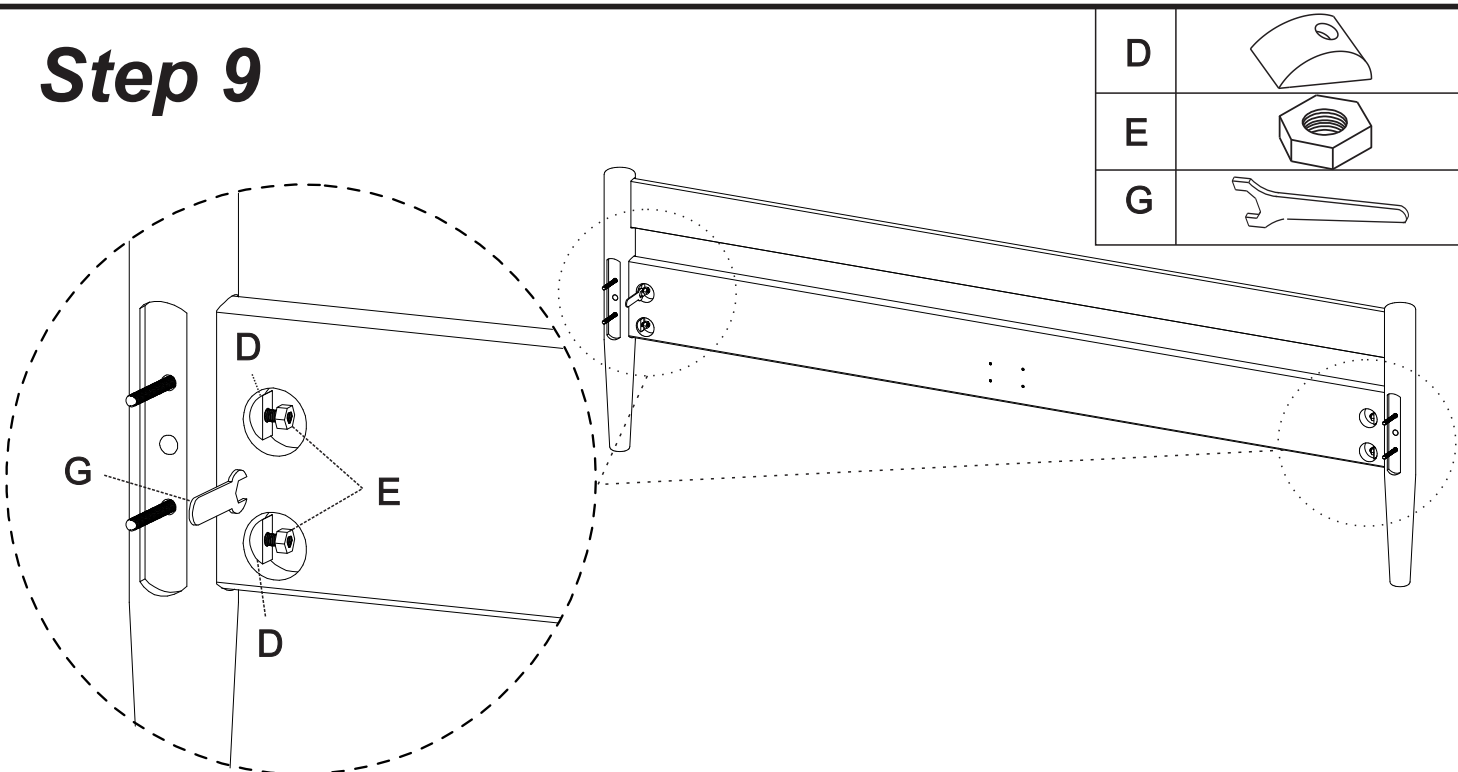

Insert washer (D) and nut (E) as in the picture. After use Spanner (G) to tighten. Repeat the same process at both sides.

# Step 10

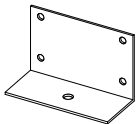

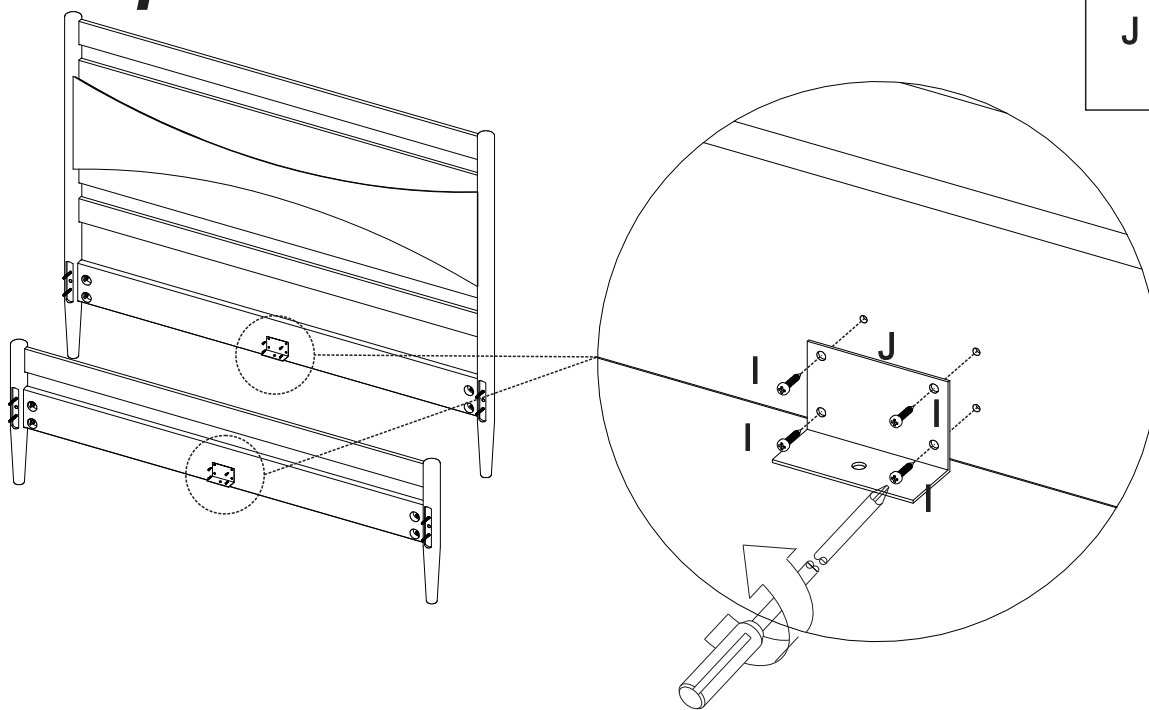
I	16mm	
J		



Use screws (I) to fix (J) hardware.

Repeat this process at two parts.

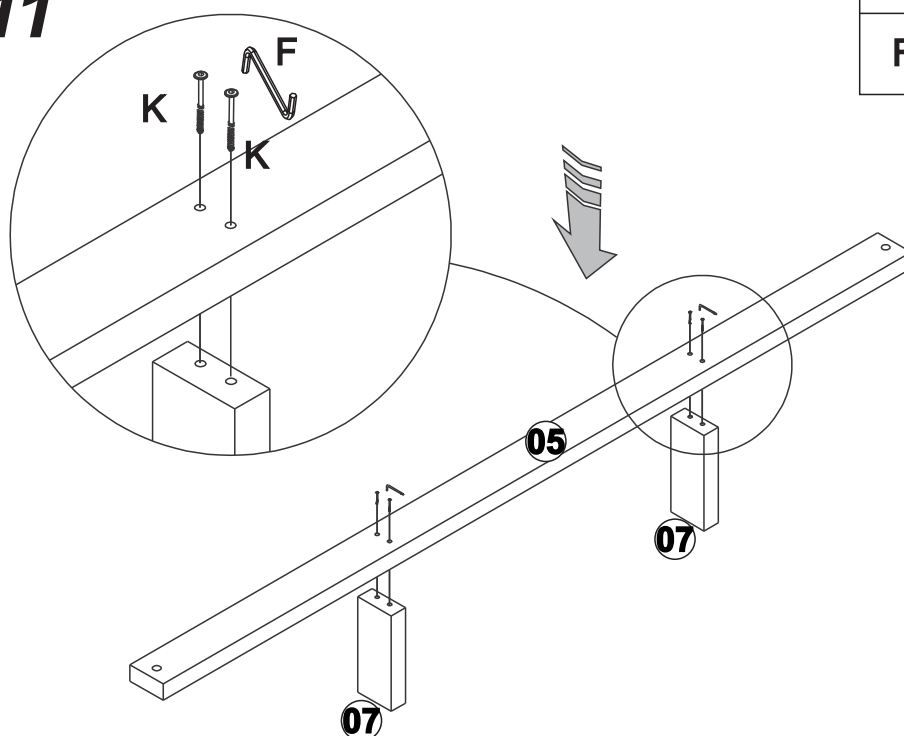

# Step 11

K	50mm	
F		

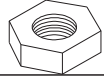

Attach central support 05 to feet 07 using wood joint connectors (K).

# Step 12

D	
E	
G	

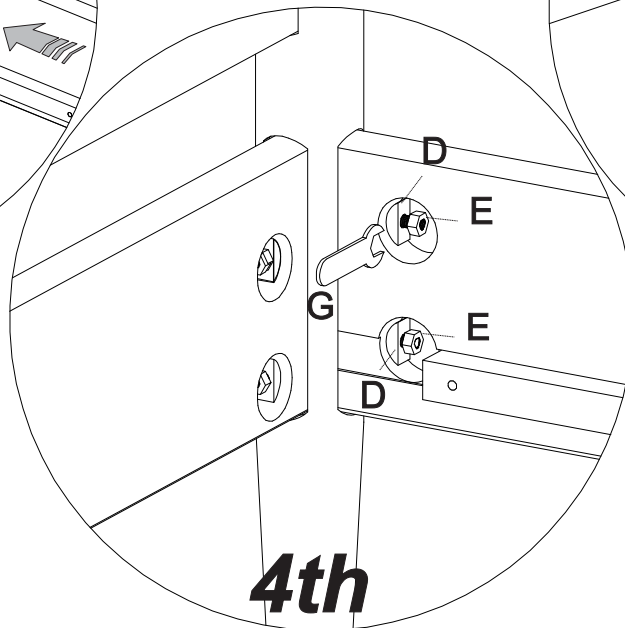
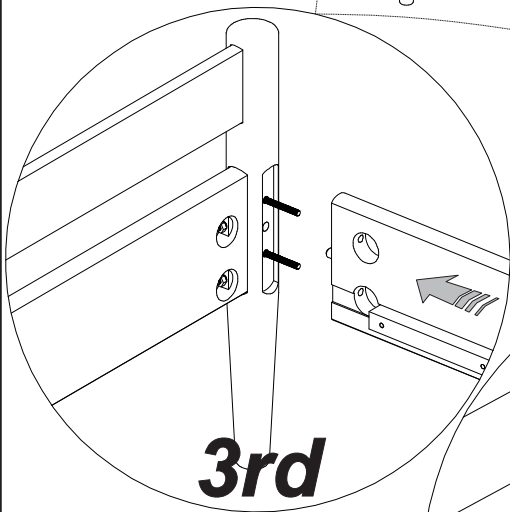
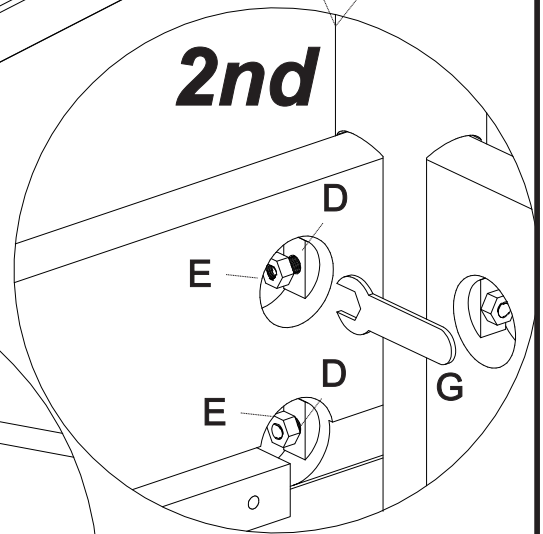
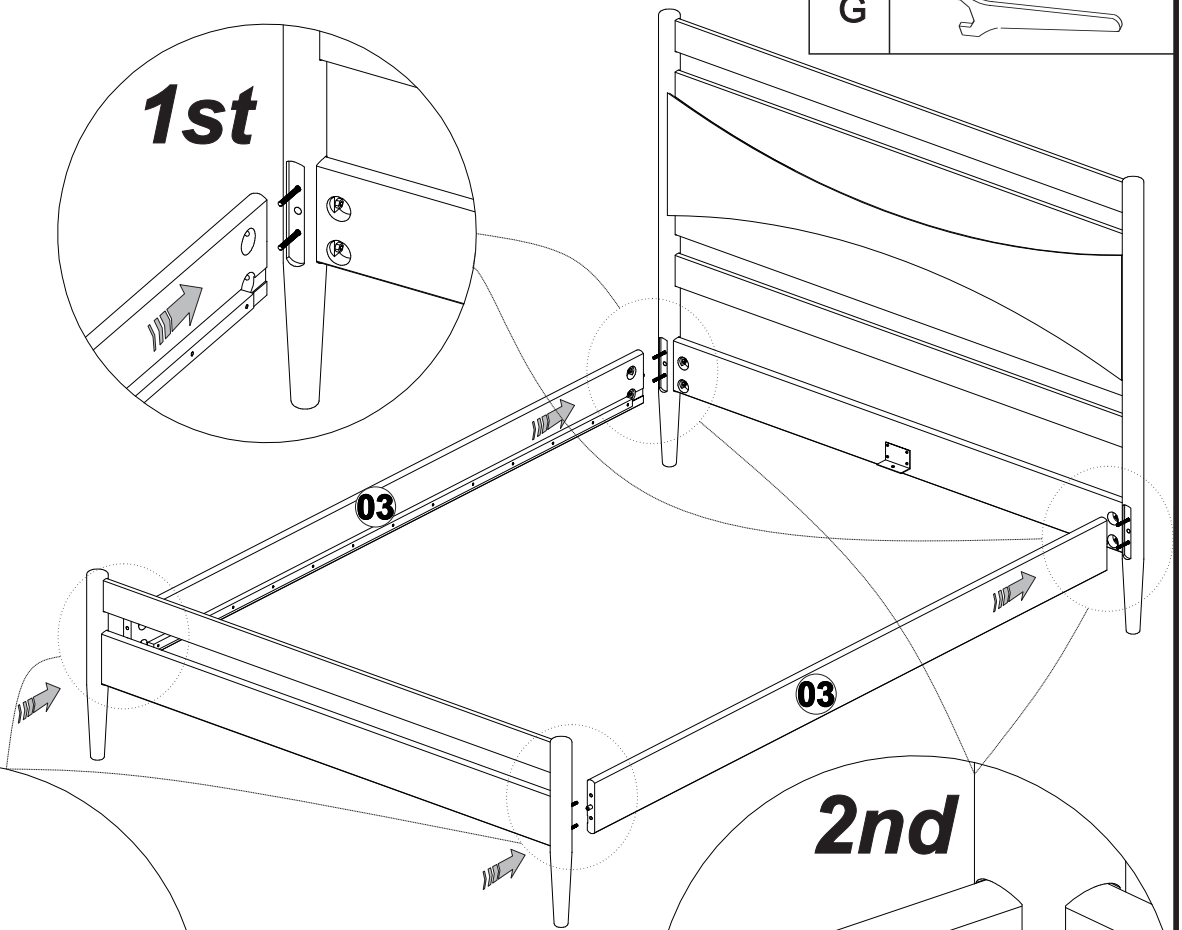
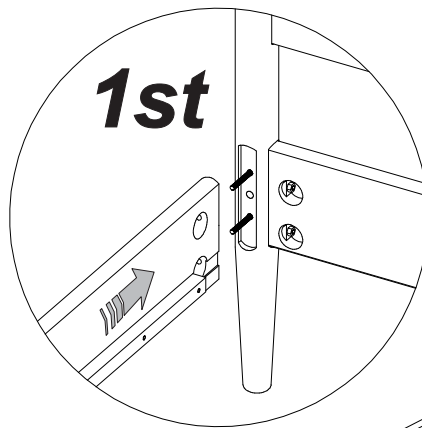

Assemble the parts 03 on the Headboard (1st)

Insert washer (D) and nut (E) as in the picture(2nd). After use Spanner (G) to tighten.

Assemble the Footboard (3rd) and Insert washer (D) and nut (E) as in the picture(4th). After use Spanner (G) to tighten.

## Step 13

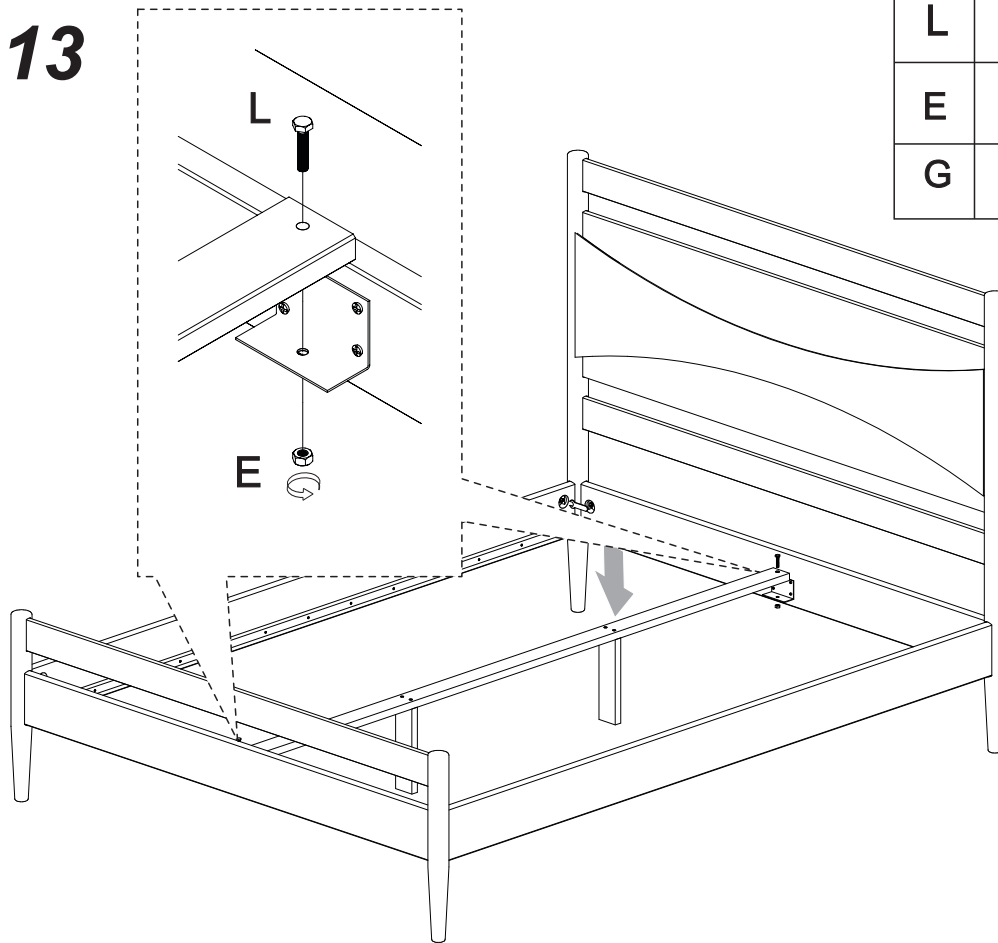

Insert Bolt (L) and nut (E) as in the picture. After use Spanner (G) to tighten. Repeat the same process at both sides.

## Step 14

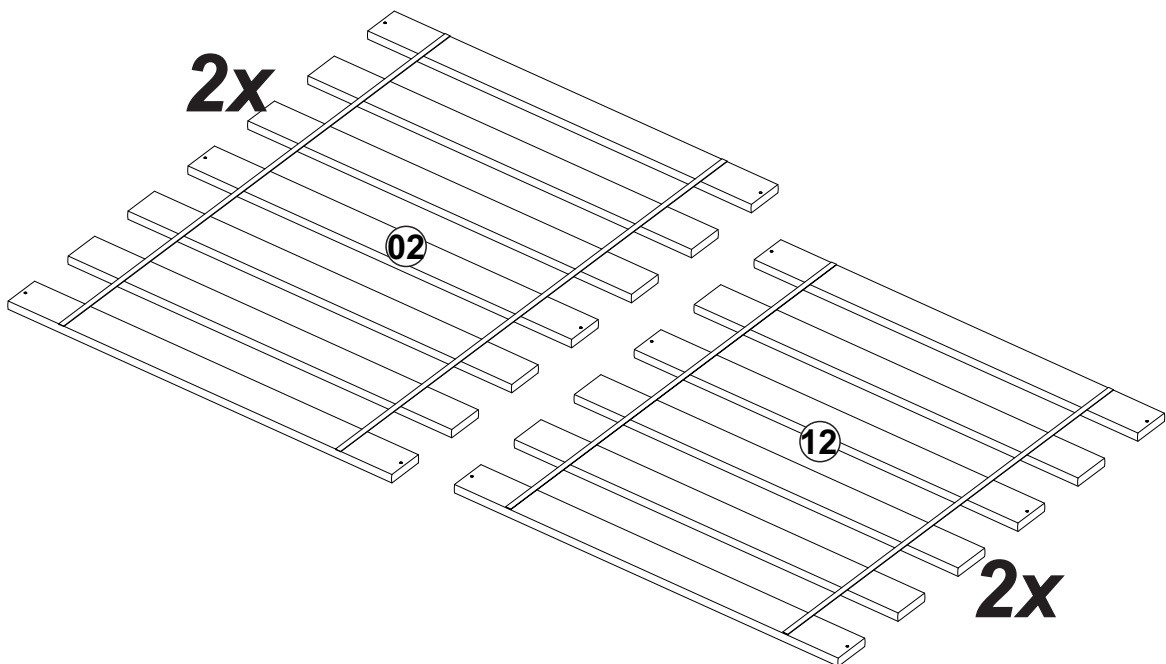

InVisually identify the two sets of slats.

# Step 15

H

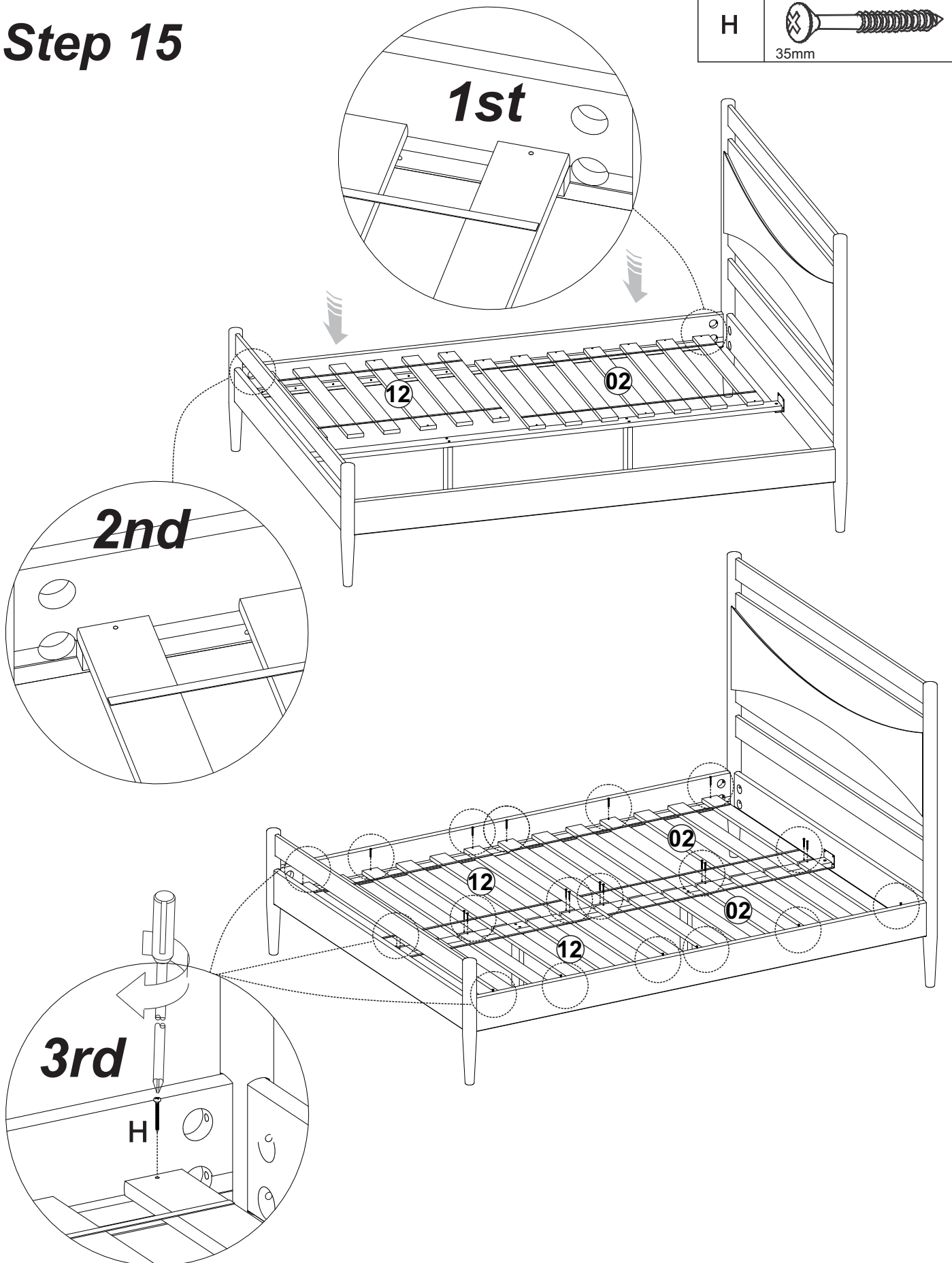
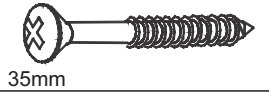

- Position the set slat 02 and align as shown in picture (1st)
- Position the set slat 12 and align as shown in picture (2nd)
- Repeat this process at two sides.
- Use screws (H) to fix all indicated slats.