

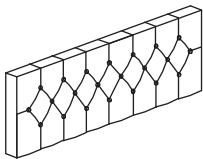

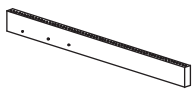

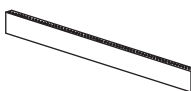

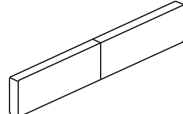



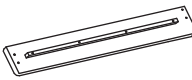

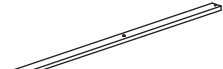

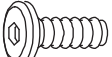
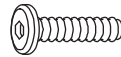
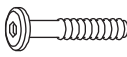



ASSEMBLY INSTRUCTION

SH215BGE-1 & SH215BLU-1 & SH215GRY-1 & SH215DGR-1 & SH215PNK-1

1 Headboard	2 Wing (L)	3 Wing (R)	4 Footboard	5 Footboard Leg
				
x1	x1	x1	x1	x2
6 Side Rail (L/R)	7 Side Rail (L/R)	8 Side Rail Support Leg	9 Slat	10 Support Leg with adjustable feet
				
x2	x2	x2	x4	x4
A Bolts M8 x 20mm	B Bolts M6 x 25mm	C Bolts M6 x 35mm	D Bolts M8 x 50mm	E Bolts M6 x 70mm
				
x4	x8	x10	x4	x2
F Wood Dowel M8 x 30mm	G Wood Dowel M10 x 30mm	H Lock Washer (M6)	I Flat Washer (M6)	J Screw M4 x 32mm
				
x2	x4	x14	x14	x8
K Allen Key M5 x 65mm	L Allen Key M4 x 65mm	M Lock Washer (M8)	N Flat Washer (M8)	
				
x1	x1	x4	x4	

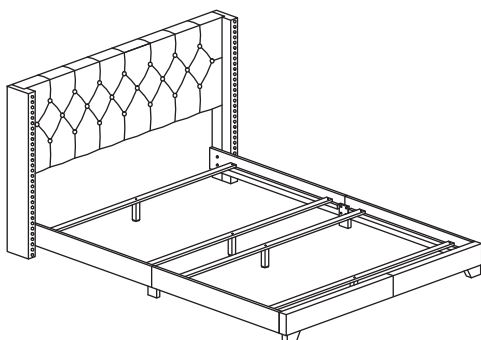

This page lists all the contents included in the box. Please take the time to identify the hardware as well as the individual components to this product. As you unpack and prepare for assembly, place the contents on a carpeted or padded area to protect them from damage.

ASSEMBLY INSTRUCTION

SH215BGE-1 & SH215BLU-1 & SH215GRY-1 & SH215DGR-1 & SH215PNK-1

- 1** Attaching each Wing (2) & (3) to each side of Headboard (1) by aligning the hole and securing with 3 Allen Bolts (C) , 3 Lock Washer (H) , 3 Flat Washer (I) per side using Allen key (L).

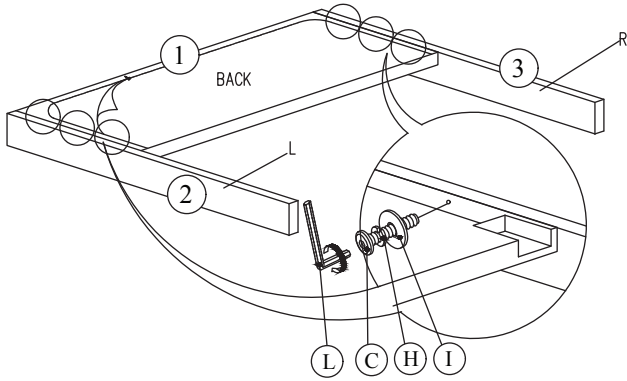

- 2** Attach each Footboard Legs (5) to the bottom of the Footboard (4) by inserting a Dowel (F) & securing with 1 Allen Bolt (E) per leg using Allen Key (L).

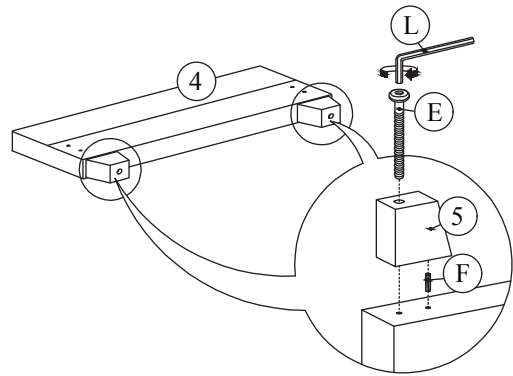

- 3** Attach the Side Rail Support Legs (8) to the join of the Side Rail (6) & Side Rail (7) by securing with 4 Allen Bolts (B) , 4 Lock Washer (H) , 4 Flat Washer (I) per support using Allen Key (L).

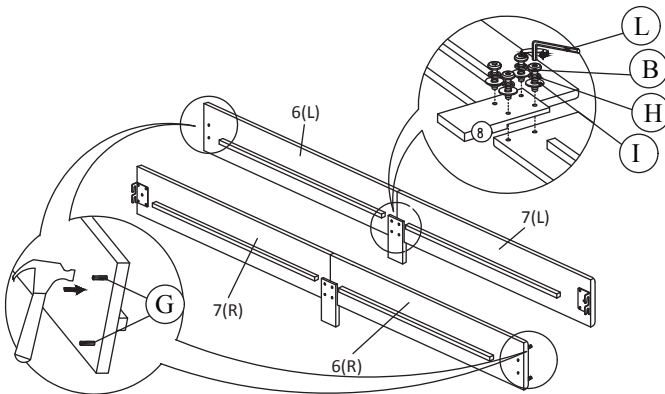

- 4** Attach Side Rail to the Wing (2) & (3) by inserting 2 Wood Dowel (G). Aligning the holes and securing with 2 Allen Bolts (D) , 2 Lock Washer (M) , 2 Flat Washer (N) each side using Allen Key (K). Attached Side Rail to Footboard (4) by securing with 2 Allen Bolts (A) using Allen Key (K).

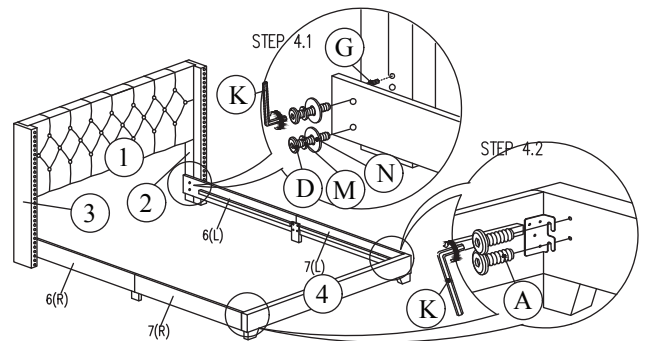

- 5** Attach Support Legs (10) to Slat (9) by securing with 1 Allen Bolt (C) per support leg. Attach Slat (9) to Side Rail by securing with 1 Screw driver (J) per each side. Tighten all screws using philips head screw driver (NOT INCLUDED). Tighten all bolts on step 3 & 4 using L-key (K) & tighten bolts on step 5 using L-key (J).

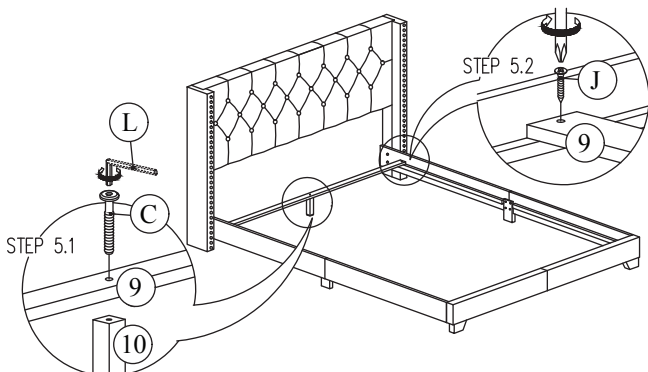

Cleaning & Care

Treat surface with care. Surface is resistant to scratches but is not scratch resistant. Clean surfaces with a dry or damp soft cloth. Do not use abrasive cleaners. Hardware may loosen over time. Periodically check that all connections are tight.