

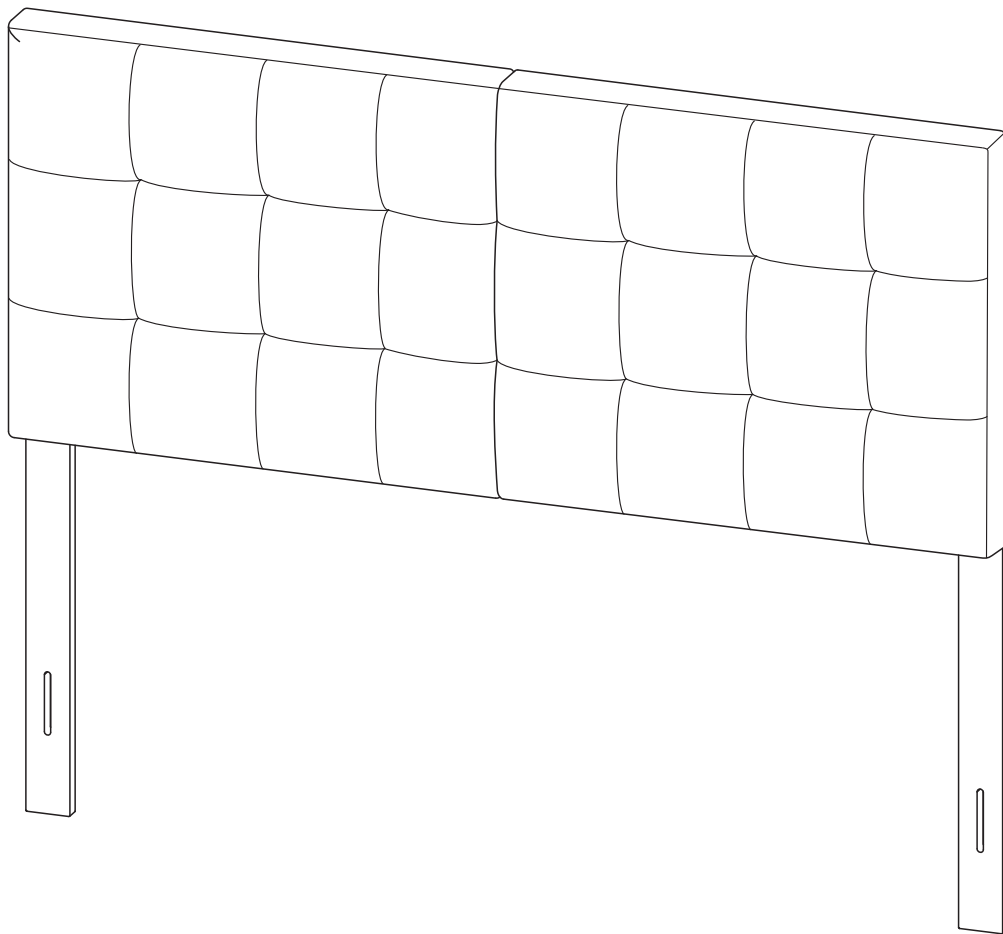

REV 01



**33650 Headboard**

## ***PLEASE CONTACT US FOR QUESTIONS***

---

Email our support team: [help@ovis.co](mailto:help@ovis.co)

### **CAUTION:**

When placing furniture on non-carpeted flooring, we recommend the use of floor protection such as an area rug or furniture pads. Area rugs and padding not included with purchase.



Estimated Time for Assembly

**10:00 - 15:00**

## ***PLEASE CONTACT US FOR QUESTIONS***

---

Email our support team: [help@ovis.co](mailto:help@ovis.co)

Bed parts are shipped inside a compartment in the back of the right half side of headboard view from back.

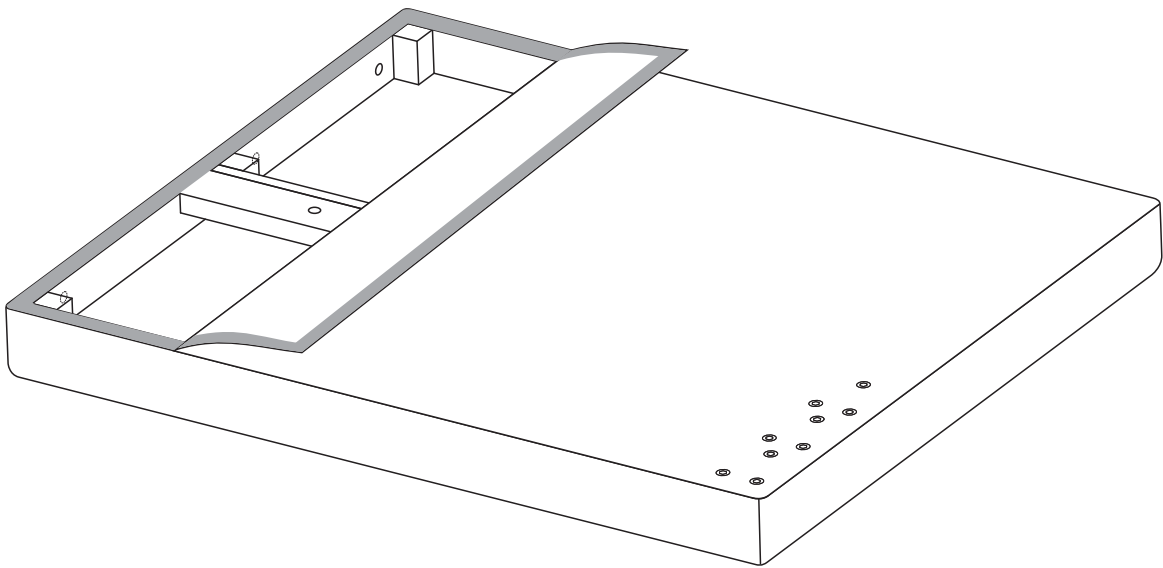

***PLEASE CONTACT US FOR QUESTIONS***

---

Email our support team: [help@ovis.co](mailto:help@ovis.co)

**Remove parts from headboard  
compartment**

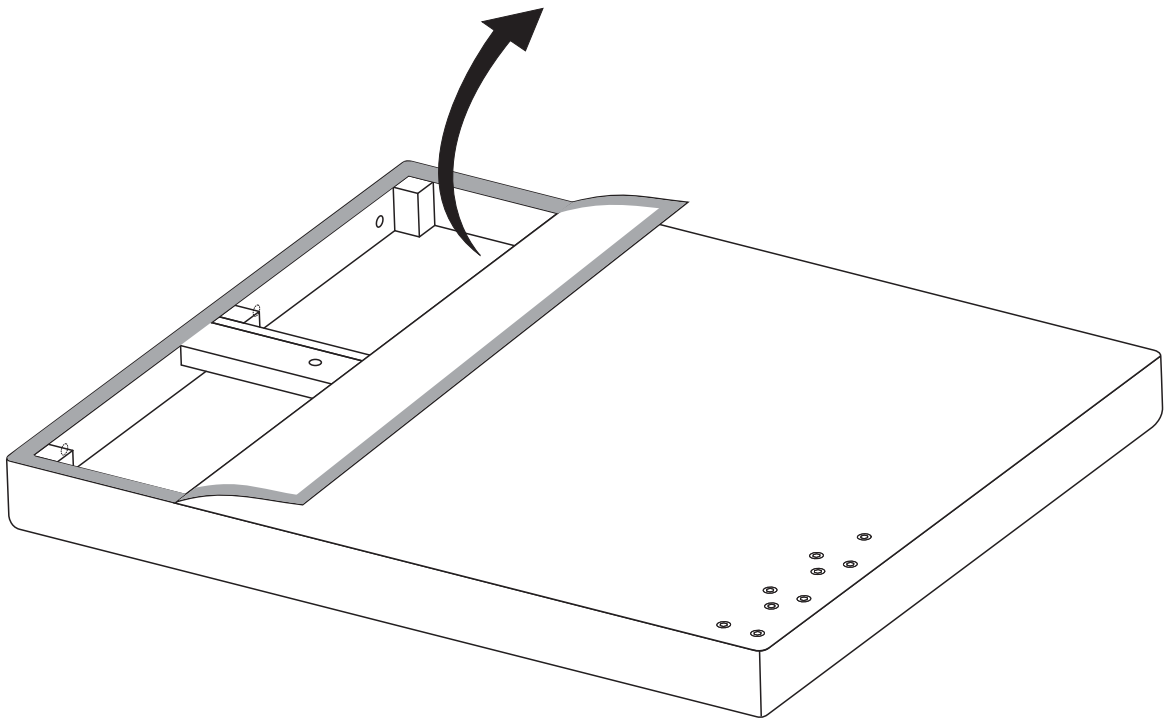

# PACKAGE CONTENT

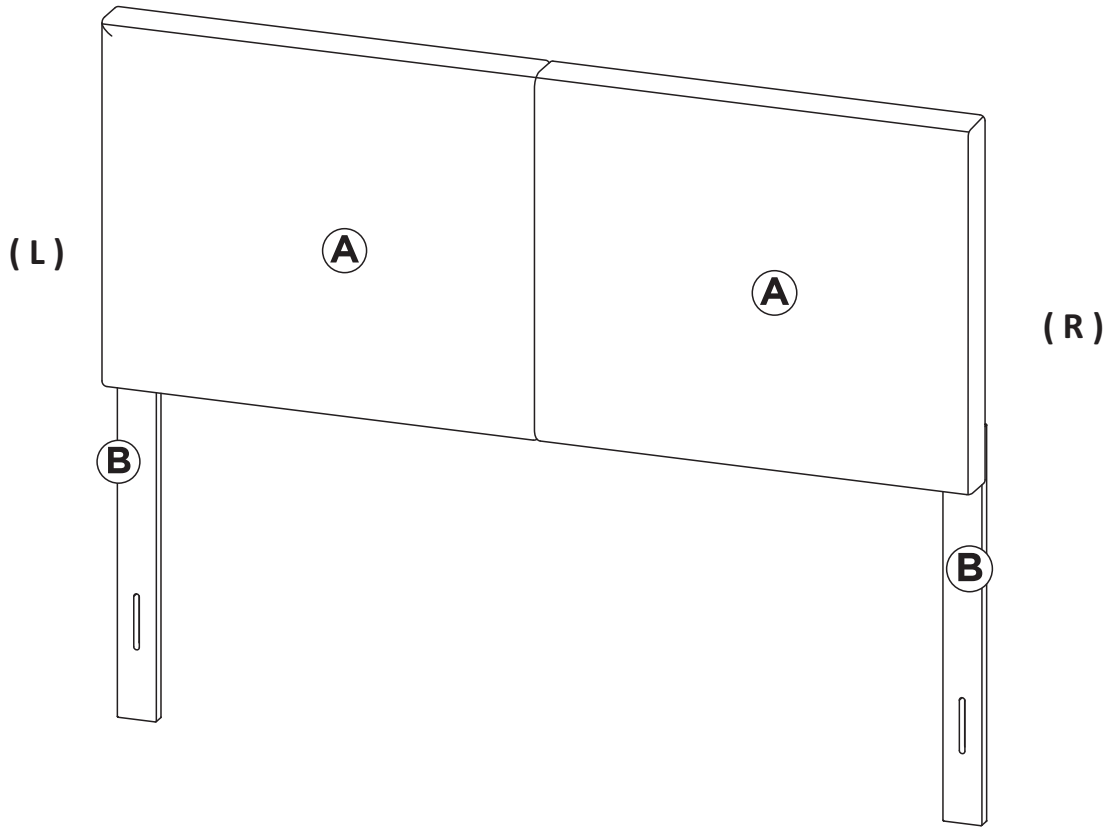

Split Headboard

## Components

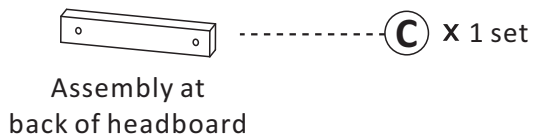
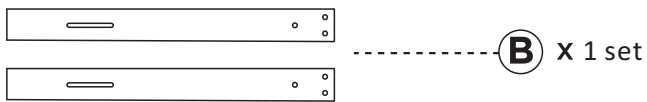
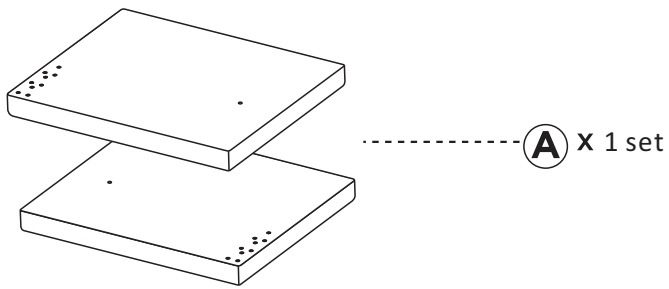

## Hardware

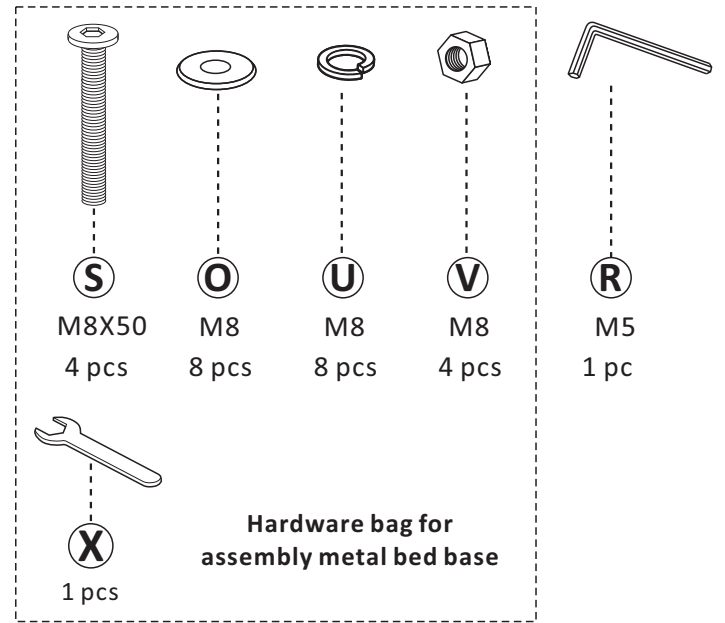
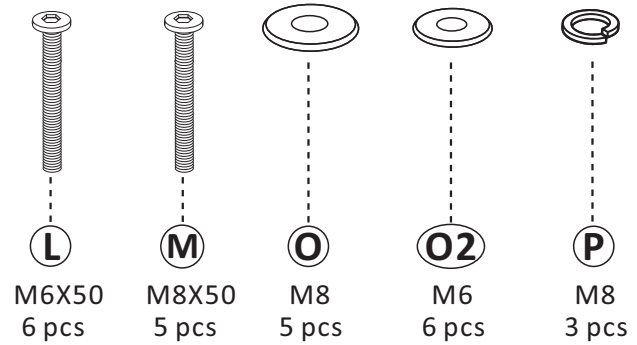

# 1.

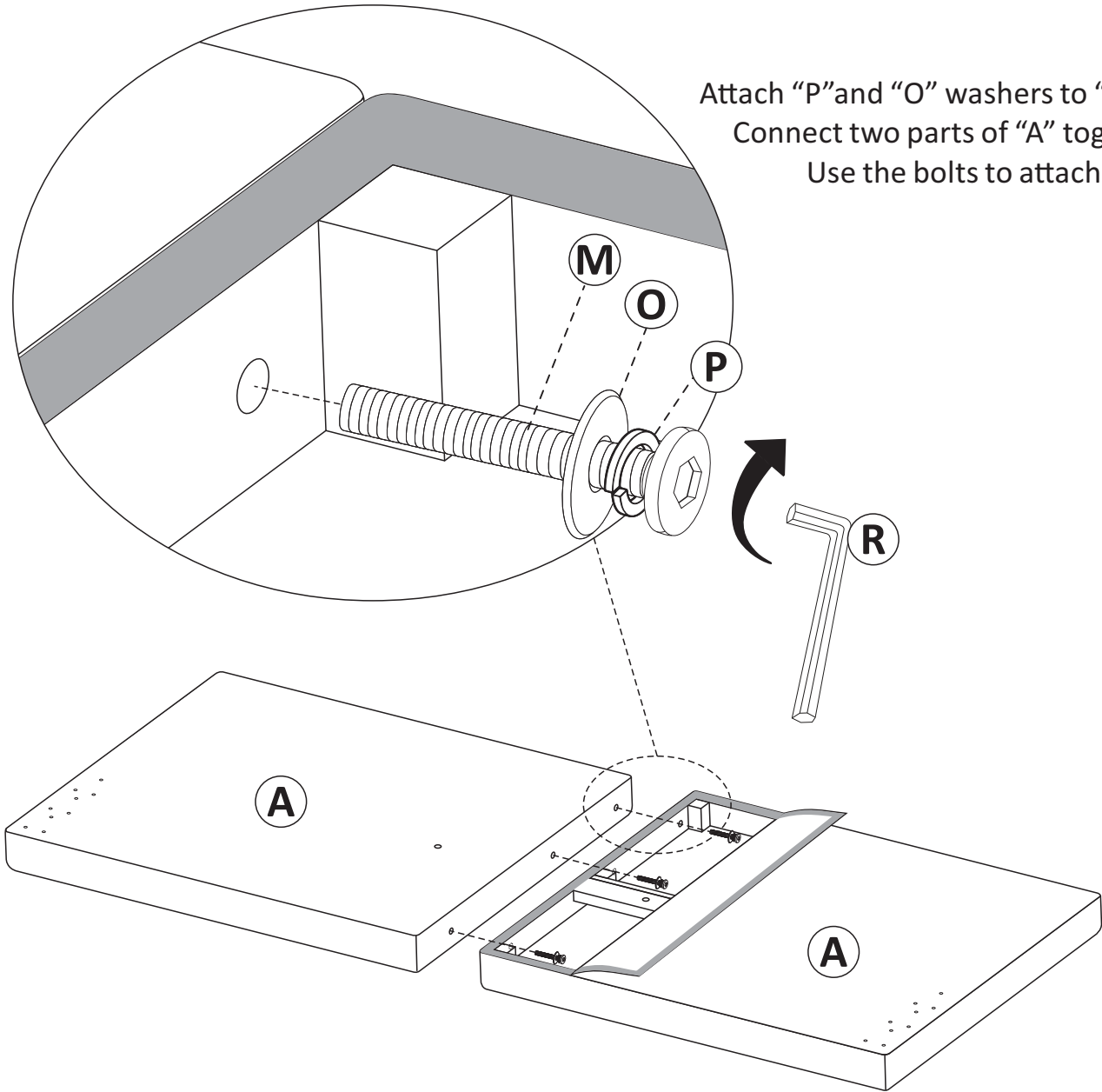
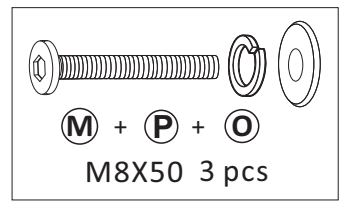

2.

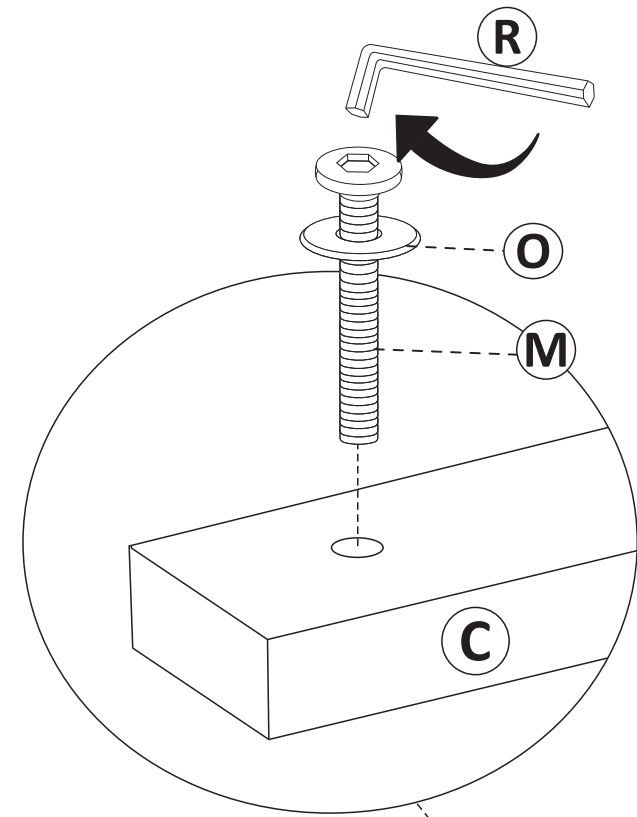
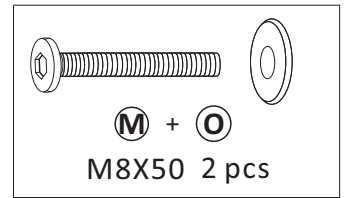

Attach "O" washer to "M" bolt.  
Connect the wood rail "C" to back  
of headboard "A".  
Use the bolts to attach.

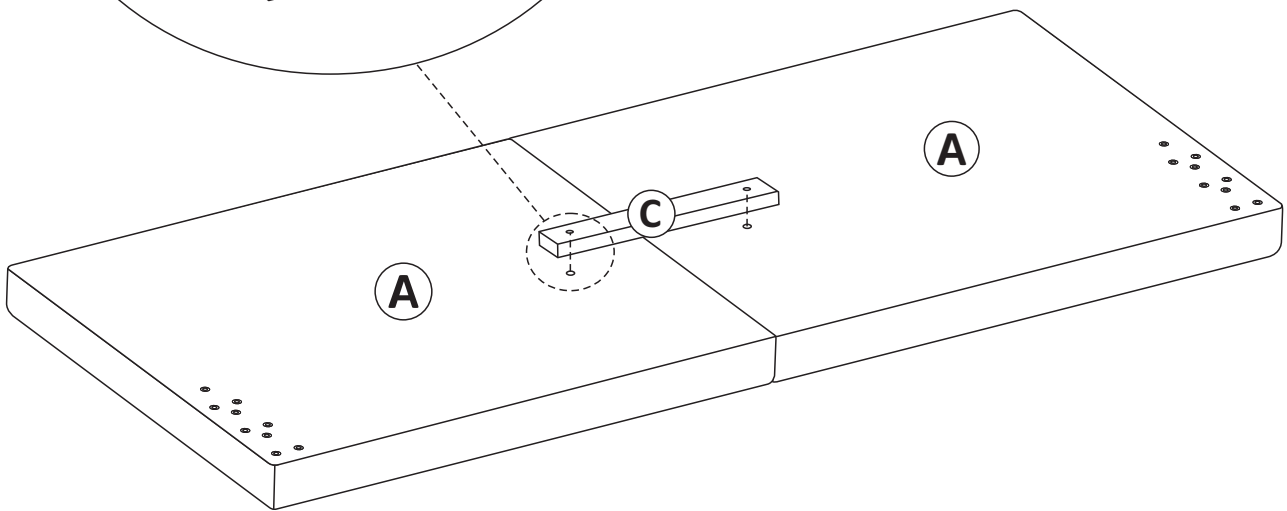

# 3.

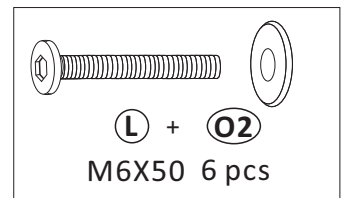

Headboard height can be adjusted to 3 positions.

Use upper holes for a thin mattress or lower holes for a thick mattress.

Select the proper position for your desired bed height.

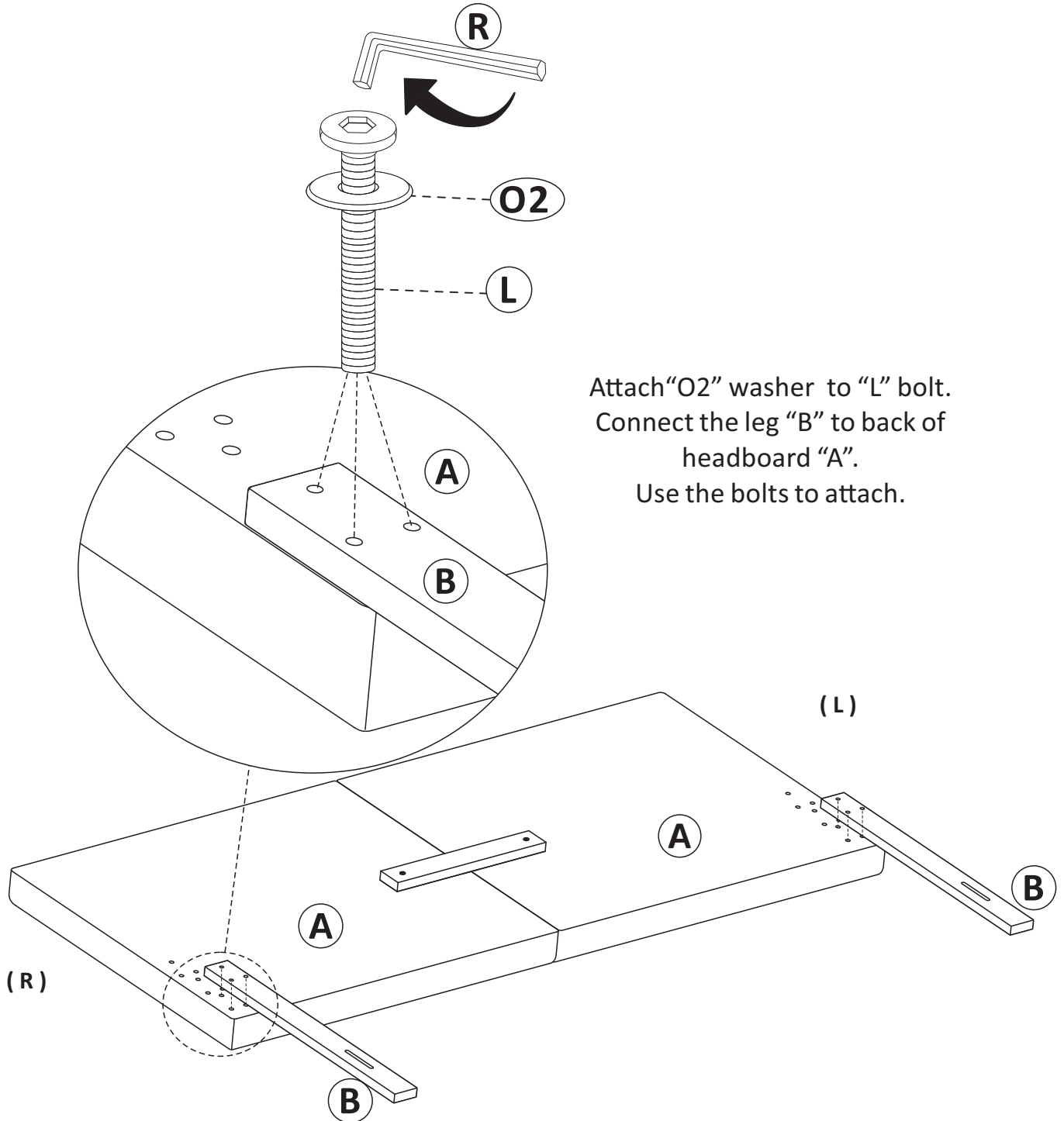



4.

Attach “U” and “O” washers to bolt “S”. Hold the bolts “S” steady with the “R” Allen wrench. Attach a “V” nut and “O” washer to the other side of the bolt as shown. Tighten the nut against the bed frame bracket with the “X” wrench. (Bed frame is not included.)

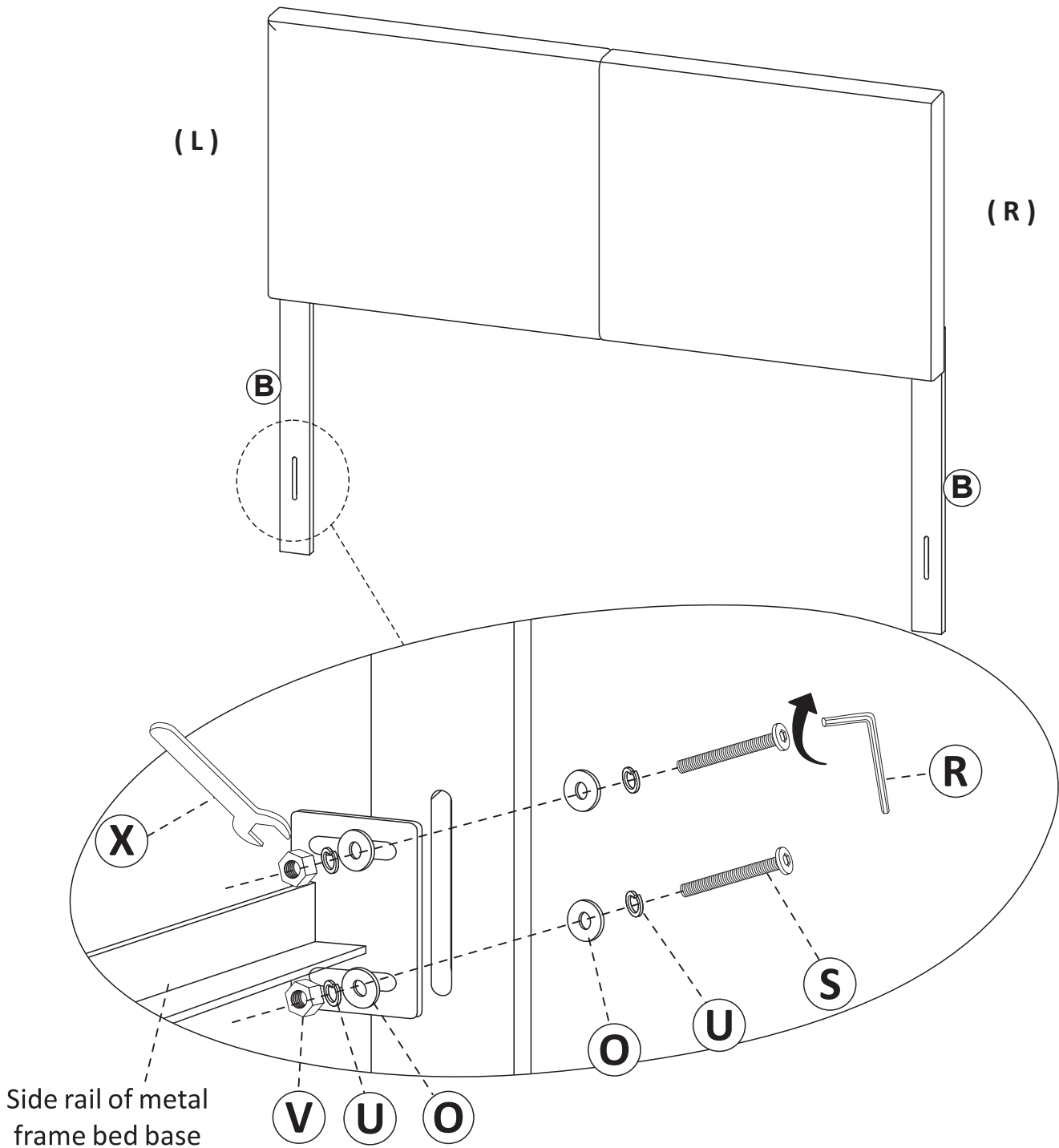

**NEED ADDITIONAL HELP?**

Email our support team: [help@ovis.co](mailto:help@ovis.co)