



# ASSEMBLY INSTRUCTIONS

AUGR RTG1576-60H QUEEN PANEL HEADBOARD  
 AUGR RTG1576-60F QUEEN PANEL FOOTBOARD  
 AUGR RTG1576-60R QUEEN & KING SIDE RAILS

SKU: 32315764  
 SKU: 32715762  
 SKU: 32915766

**Caution:** Please read instructions thoroughly before unpacking assembly parts.

1. We recommend that you assemble this product with the assistance of another person. This will make assembly easier and help to eliminate damage to the product or injury to persons during assembly.
2. Be sure to check all packing materials carefully for small parts that may have come loose inside the carton during shipment.
3. Please put all parts on a non-abrasive surface and follow the assembly steps to assemble your newly purchased product correctly and efficiently.

No	Hardware List		Qty
①	Wood Screw	Ø8x32mm	8pcs
*Above Hardware Parts packed in RTG1576-65F for assembly.			

No	Description	Sketch	Qty
(A)	Headboard		1pc
*Above Parts packed in RTG1576-60H.			
(B)	Footboard		1pc
(C)	Slats		4pcs
(D)	Long Support Leg		4pcs
(E)	Short Support Leg		4pcs
*Above Parts packed in RTG1576-60F.			
(F)	Side Rails		2pcs
*Above Parts packed in RTG1576-60R.			
Assembly Requires Phillips Head screwdriver (not included).			

## STEP 1

Loosen the Allen Bolt, Spring Washer, Flat Washer in the Headboard (A) and Footboard (B) with Allen Wrench (2). Do not remove the bolt, leave it inserted halfway.

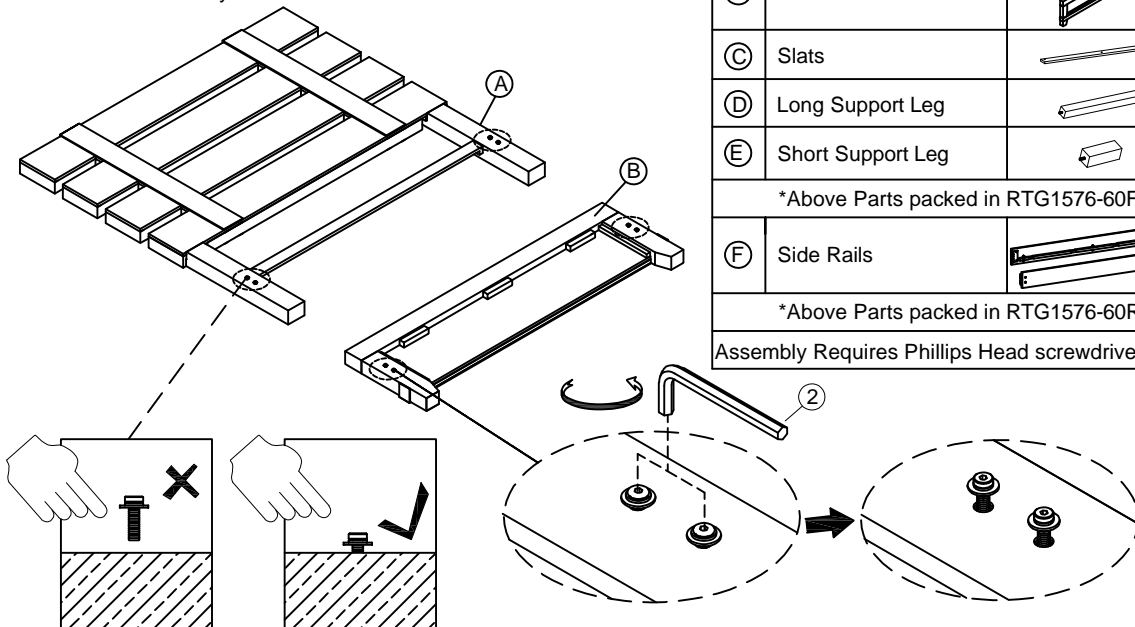

## STEP 2 (Option 1 - Low Position)

Thread Long Support Legs (F) into the insert nut on Slats (E). Short Support Legs (E) will not be use in Option 1.

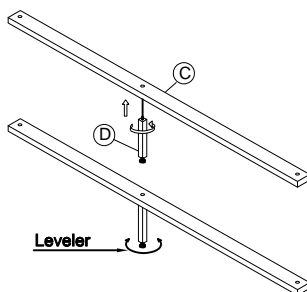

## STEP 2 (Option 2- High Position)

Thread Short Support Legs (G) into the insert nut on Slats (E) and then Thread Long Support Legs (F) into the insert nut on Short Support Legs (G) as show below.

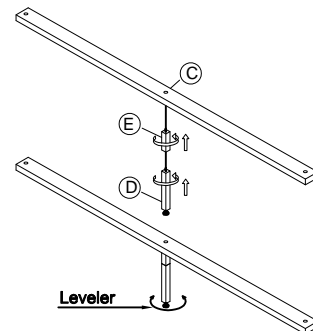

## Hardware Pack Location(s):

AUGR RTG1576-60F QUEEN PANEL FOOTBOARD

SKU: 32715762



# ASSEMBLY INSTRUCTIONS

AUGR RTG1576-60H QUEEN PANEL HEADBOARD  
AUGR RTG1576-60F QUEEN PANEL FOOTBOARD  
AUGR RTG1576-60R QUEEN & KING SIDE RAILS

SKU: 32315764  
SKU: 32715762  
SKU: 32915766

**Caution:** Please read instructions thoroughly before unpacking assembly parts.

1. We recommend that you assemble this product with the assistance of another person. This will make assembly easier and help to eliminate damage to the product or injury to persons during assembly.
2. Be sure to check all packing materials carefully for small parts that may have come loose inside the carton during shipment.
3. Please put all parts on a non-abrasive surface and follow the assembly steps to assemble your newly purchased product correctly and efficiently.

## STEP 3

Attach Side Rail (H) to Headboard Leg (B) and Footboard (D). Place the Side Rail (H) bracket hooks onto the Bolts loosened in Step 1. Apply downward force until they are fully in place. Tighten with Allen Wrench (2).

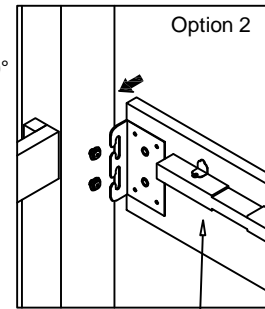
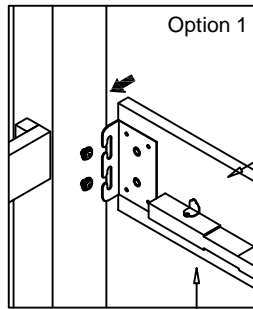
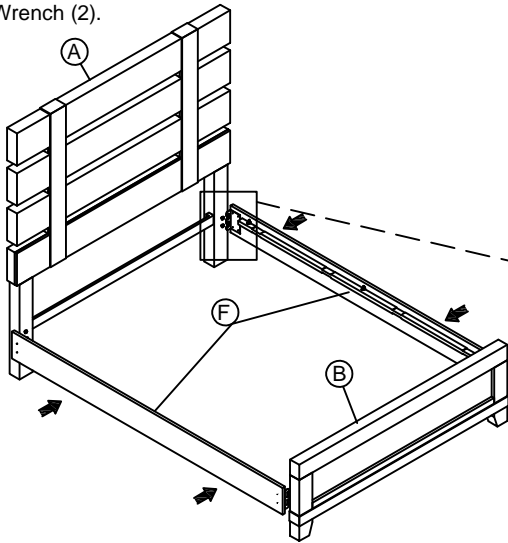

Low position

High position

STEP 5-1

STEP 5-2

STEP 5-3

**STEP 4A.** Attach Slats (E) to Side Rails (H) using Wood Screw (3) using a Phillips Head screwdriver (not included).

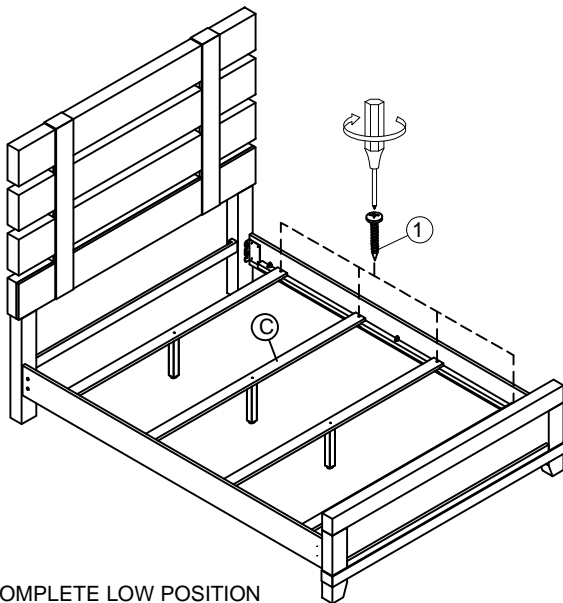

COMPLETE LOW POSITION

**STEP 4B.** Attach Slats (E) to Side Rails (H) using Wood Screw (3) using a Phillips Head screwdriver (not included).

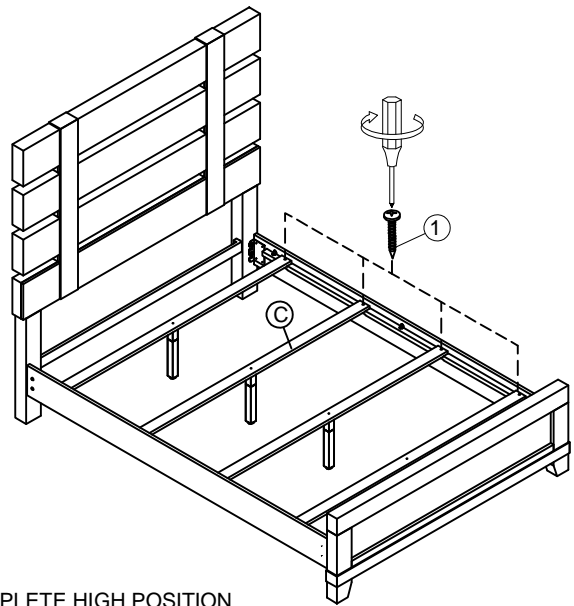

COMPLETE HIGH POSITION

**Hardware Pack Location(s):**

AUGR RTG1576-60F QUEEN PANEL FOOTBOARD

SKU: 32715762