





# ASSEMBLY INSTRUCTION

GBHS 1708-3 / 1708-7 / 1708-9 QUEEN BED SKU# 32317085 / 32717083 / 32917087

THANK YOU FOR PURCHASING THIS QUALITY PRODUCT. BE SURE TO CHECK ALL PACKING MATERIAL CAREFULLY FOR SMALL PARTS, WHICH MAY HAVE COME LOOSE INSIDE THE CARTON DURING SHIPMENT. IDENTIFY AND COUNT ALL PARTS AND COMPARE WITH THE HARDWARE LIST BELOW.

| COMPONENT LIST |                |      |
|----------------|----------------|------|
| NO             | DESCRIPTION    | QTY. |
| A              | HEADBOARD      | 1    |
| B              | HEADBOARD BASE | 1    |
| C              | FOOTBOARD      | 1    |
| D              | SIDE RAIL      | 2    |
| E              | SLATS          | 5    |
| F              | CENTER LEG     | 5    |

| HARDWARE LIST IN HEADBOARD & FOOTBOARD |   |      |
|--|---|------|
| NO                                     | DESCRIPTION   | QTY. |
| 1                                      | WASHER+LOCK WASHER                   | 12   |
| 2                                      | ALLEN BOLT (6x30mm-Thread count 28)  | 12   |
| 3                                      | ALLENKEY (4mm)                       | 1    |
| 4                                      | ALLENKEY (5mm)                       | 1    |
| 5                                      | SCREW                                | 10   |
| 6                                      | SCREW DRIVER (NOT INCLUDED)   | -    |

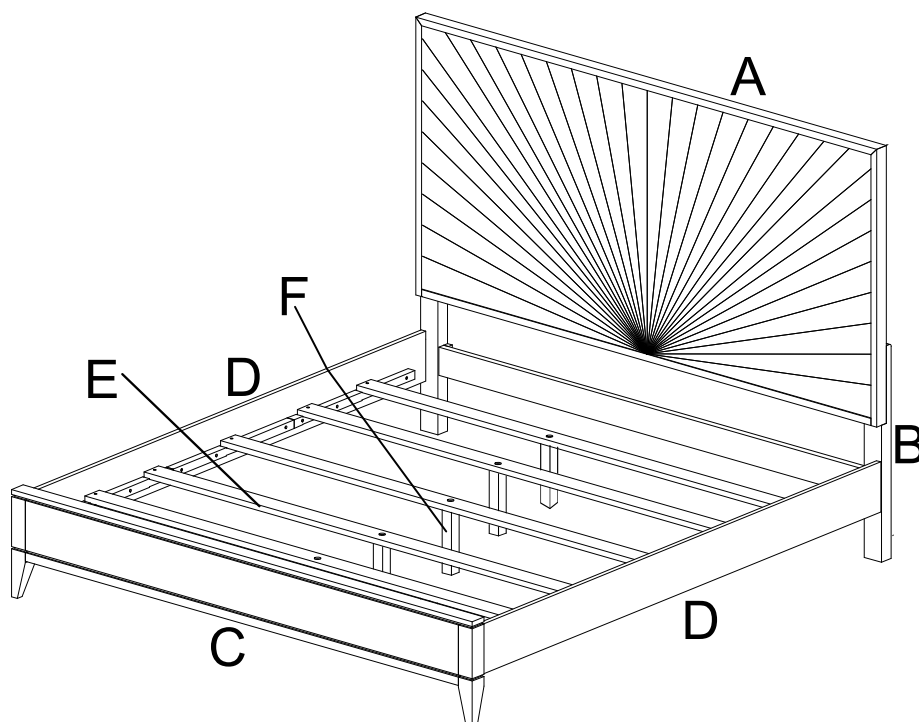

### STEP-1

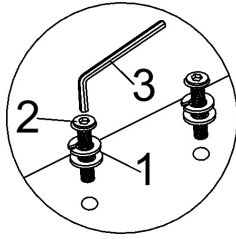

ASSEMBLE HEADBOARD FRAME TO BASE. LOOSELY INSERT ALL 12 BOLTS INTO HEADBOARD, THEN TIGHTEN ALL BOLTS.

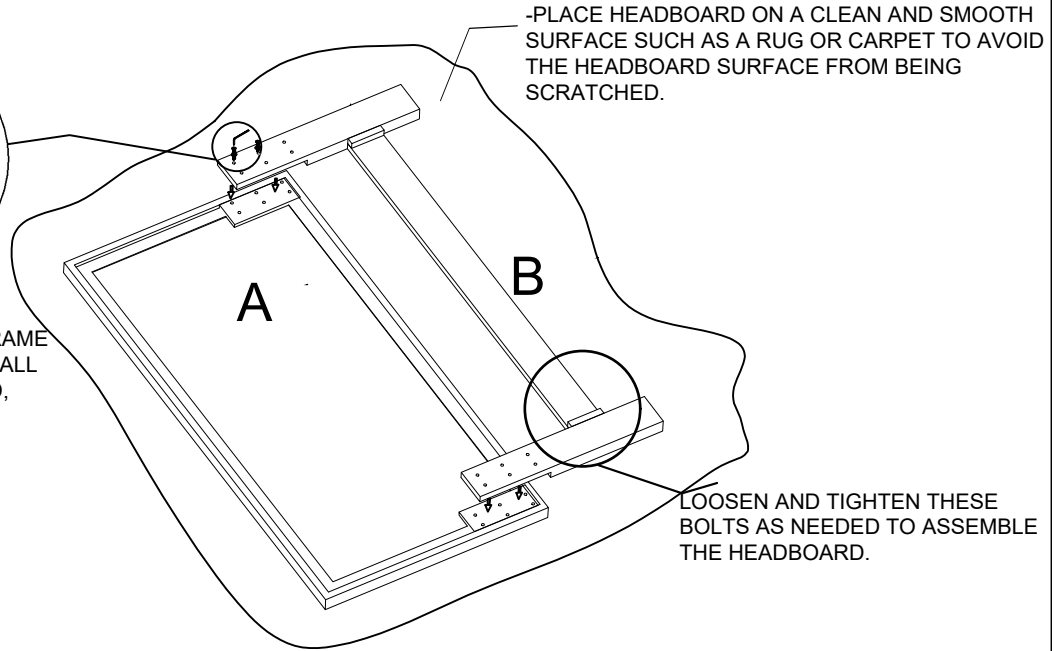

### STEP-2

ASSEMBLE HEADBOARD WITH SIDE RAIL & FOOTBOARD.

LOOSEN PRE-PARTIALLY TIGHTENED BOLTS, ALIGN SIDERAIL WITH BOLTS AS SHOWN.

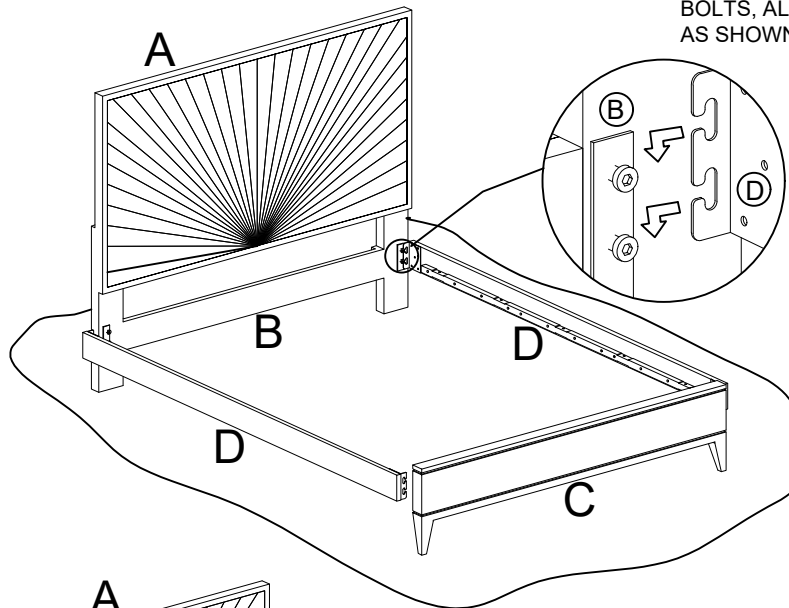

### STEP-3

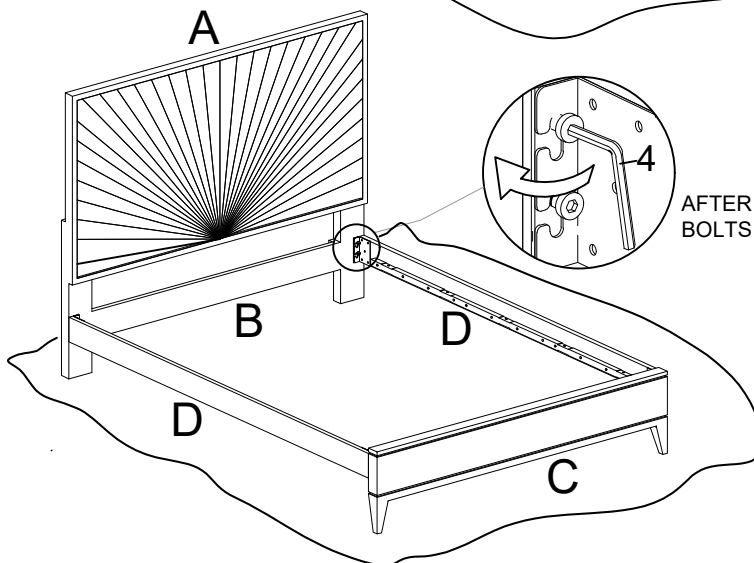

AFTER SIDERAIL SET IN POSITION TIGHTEN THE BOLTS COMPLETELY.

STEP-4

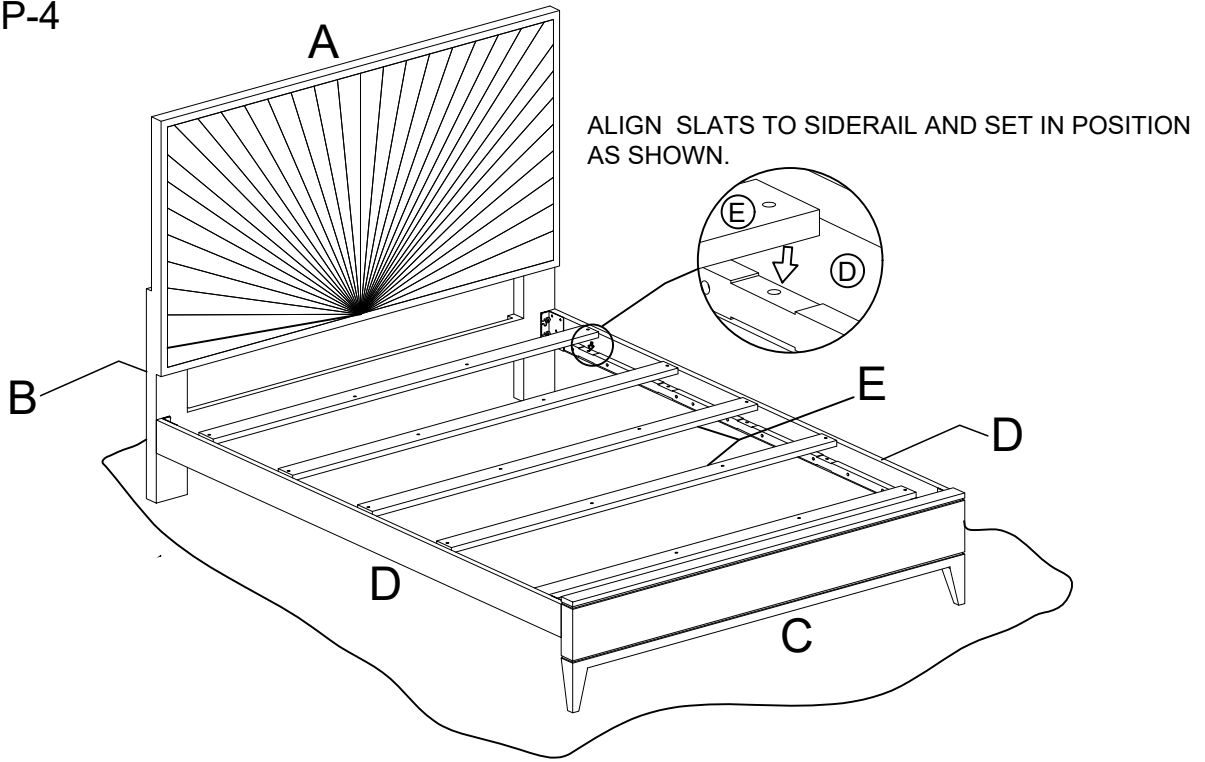

STEP-5

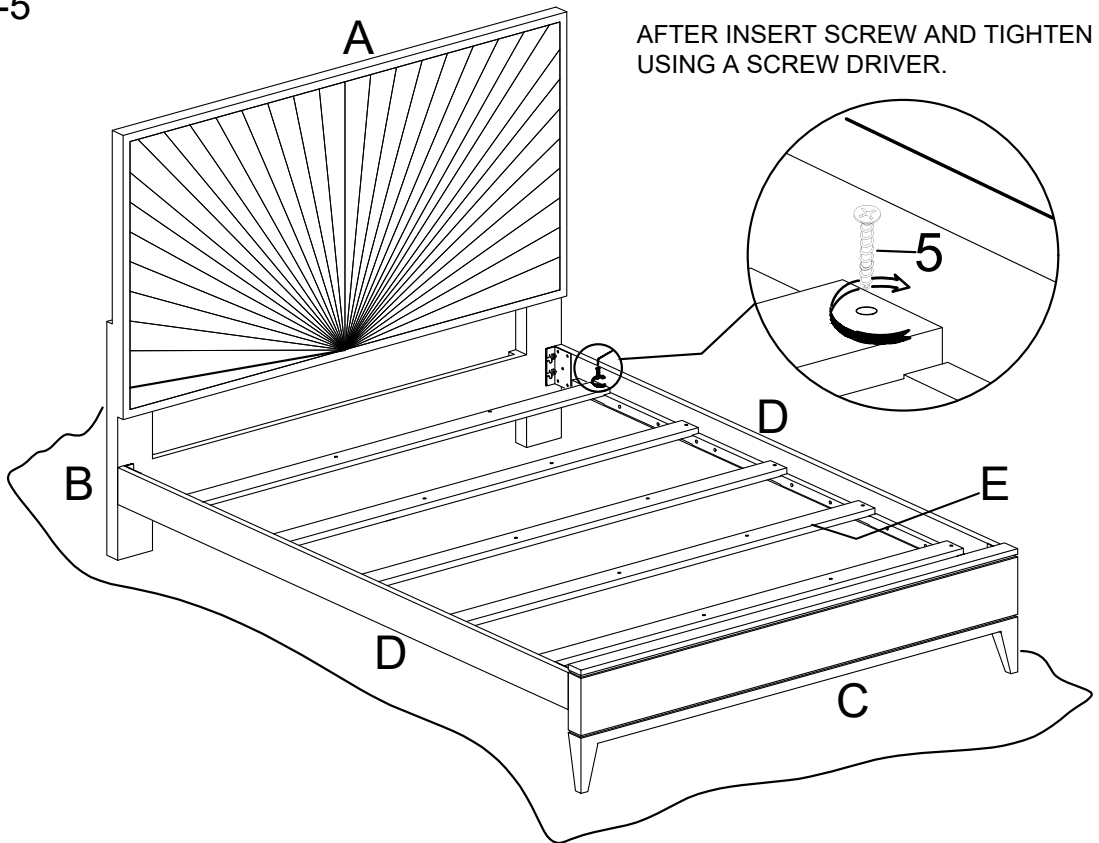

## STEP-6

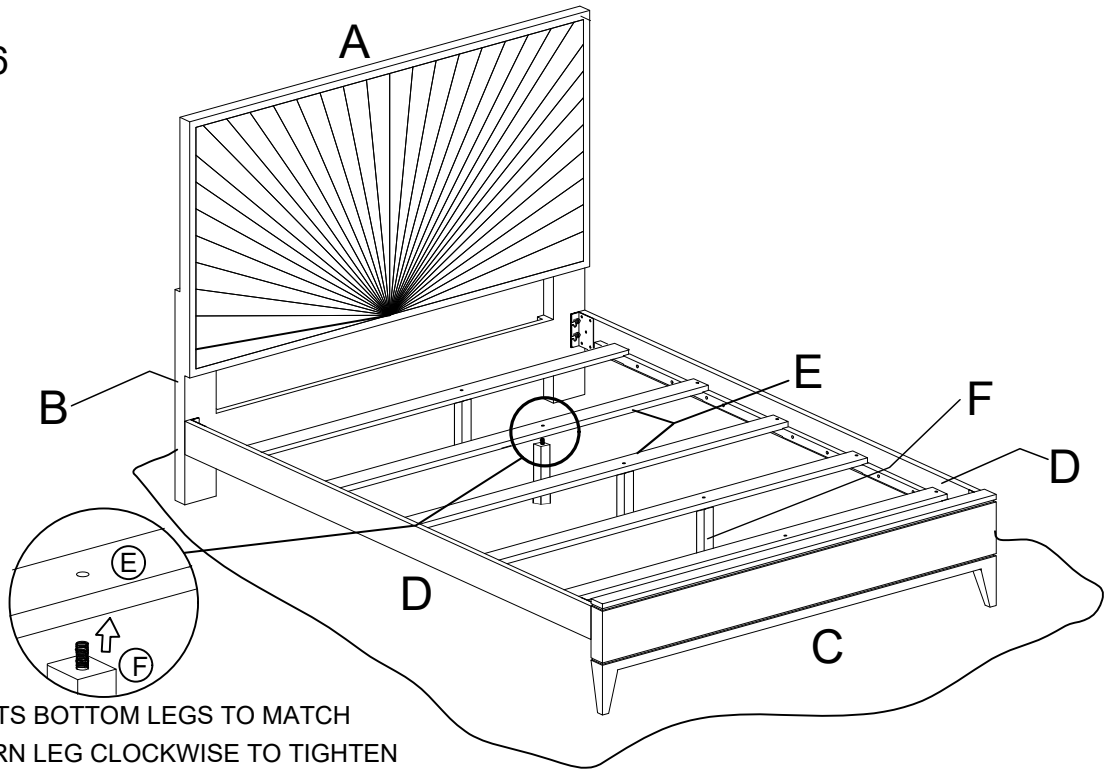

ALIGN SLATS BOTTOM LEGS TO MATCH HOLES TURN LEG CLOCKWISE TO TIGHTEN COMPLETE, REPEAT STEP FOR OTHER LEGS.

## STEP-7

COMPLETE PRODUCT

