



Assembly Instructions

PULA 3363-170 QN Panel HDBD - SKU# 32333635

PULA 3363-171 QN Panel FTBD - SKU# 32733633

PULA 3363-172 QN/KG Rails - SKU# 32933637

Manufactured by PULA for Rooms To Go

***** Caution : Please read all instructions carefully before starting the assembly process. These parts are cumbersome and heavy. Therefore, two people are recommended in order to prevent personal injury and insure the parts are not damaged during the assemble.**

PARTS LIST

No.	Description	Sketch	Q'ty
1	Panel Headboard		1 Pc
2	Panel Footboard		1 Pc
3	Slats		5 Pcs
4	Long Slat Support		5 Pcs
5	Short Slat Support		5 Pcs

HARDWARE LIST

No.	Description	Size	Sketch	Q'ty
A	Screw	M4 x 1-1/4"		10 Pcs

TOOLS REQUIRED (NOT PROVIDED)

Description	Sketch
Phillips screwdriver	

PARTS LIST

No.	Description	Sketch	Q'ty
6	Side Rail		2 Pcs

OPTION - 1

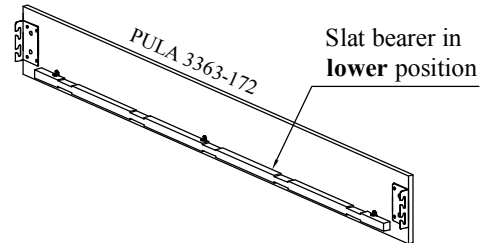
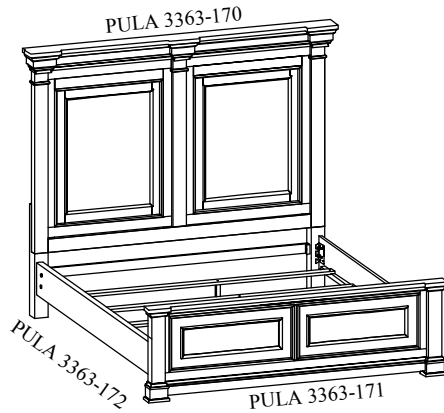

OPTION - 2

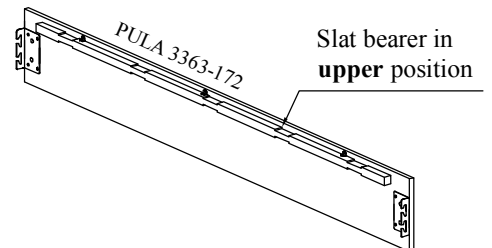
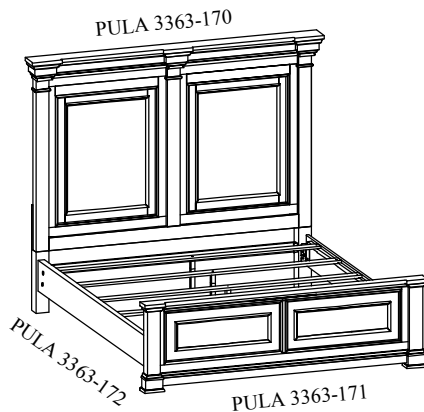

Hardware Pack Location (s): Bolts pack at footboard/ Bolts pack at rails

Queen Bed SKU# 32333635/ 32733633/ 32933637



Assembly Instructions

PULA 3363-170 QN Panel HDBD - SKU# 32333635

PULA 3363-171 QN Panel FTBD - SKU# 32733633

PULA 3363-172 QN/KG Rails - SKU# 32933637

Manufactured by PULA for Rooms To Go

***** Caution : Please read all instructions carefully before starting the assembly process. These parts are cumbersome and heavy. Therefore, two people are recommended in order to prevent personal injury and insure the parts are not damaged during the assemble.**

OPTION -1: Assembly Queen Bed with Slat Bearer in Lower Position

STEP 1.1: Assemble the Side Rails to the Headboard. Use a allen key to tight the nut. Similarly, install the Side Rails for the Footboard.

STEP 1.2: Assemble the Slat support to the Slat. When installing, the Slat support needs to be tightened to fit your hand and adjust Leveler on Support Legs for balance.

STEP 1.3: Place the Slat in the correct position on Side Rails. Then use a screwdriver to screw Slats into the Side Rails to secure it. Screwdriver (Not Provided) .

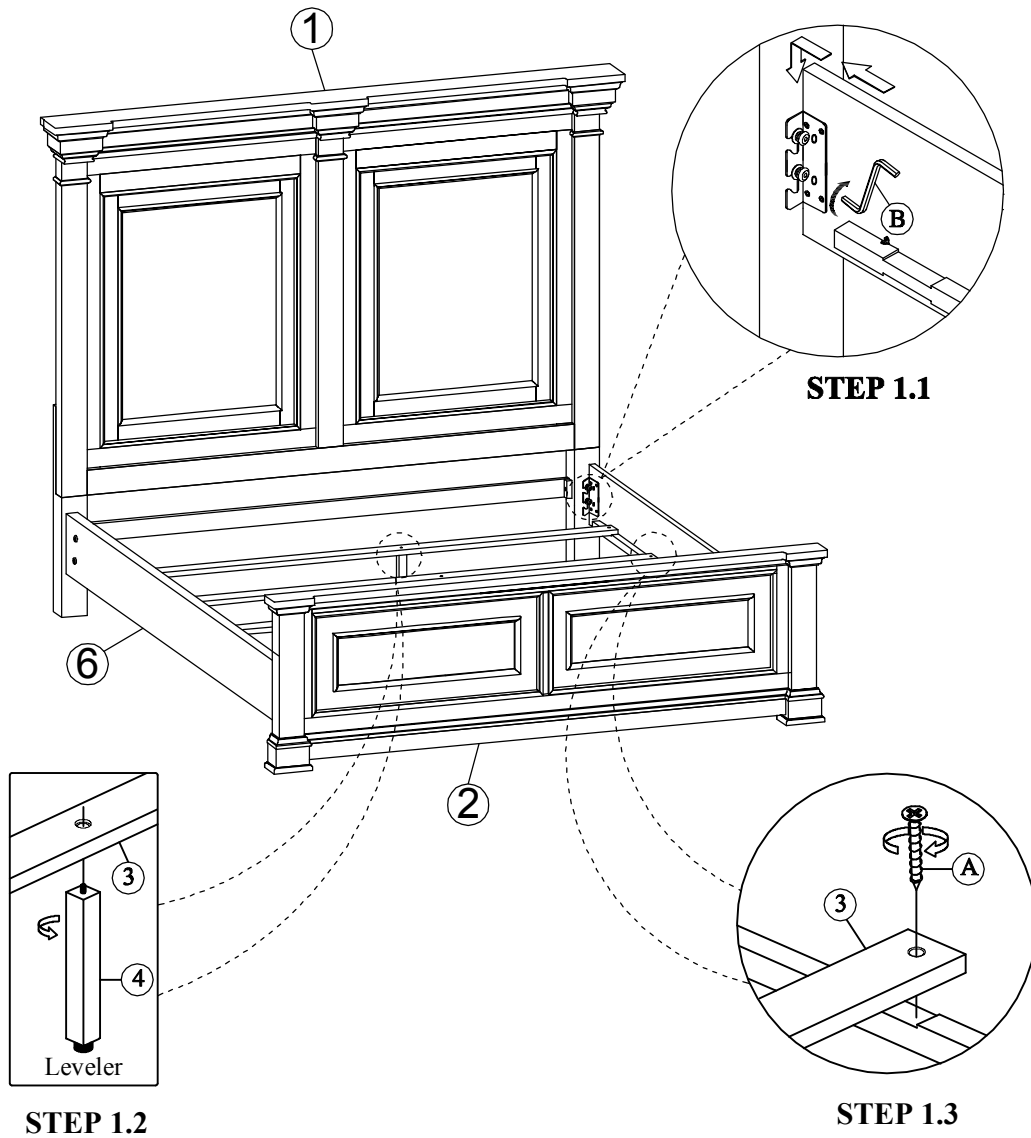

Hardware Pack Location (s): Bolts pack at footboard/ Bolts pack at rails

Queen Bed SKU# 32333635/ 32733633/ 32933637



Assembly Instructions

PULA 3363-170 QN Panel HDBD - SKU# 32333635

PULA 3363-171 QN Panel FTBD - SKU# 32733633

PULA 3363-172 QN/KG Rails - SKU# 32933637

Manufactured by PULA for Rooms To Go

***** Caution : Please read all instructions carefully before starting the assembly process. These parts are cumbersome and heavy. Therefore, two people are recommended in order to prevent personal injury and insure the parts are not damaged during the assemble.**

OPTION -2: Assembly Queen Bed with Slat Bearer in Upper Position

STEP 2.1: Assemble the Side Rails to the Headboard. Use a allen key to tight the nut. Similarly, install the Side Rails for the Footboard.

STEP 2.2: screw the short support slat into the long support slat. Then, screw the newly installed bar into the bed slats. When installing, you need to tighten the Slat support bar to fit your hand and adjust the Leveler on the Support Stand for balance .

STEP 2.3: Place the Slat in the correct position on Side Rails. Then use a screwdriver to screw Slats into the Side Rails to secure it. Screwdriver (Not Provided) .

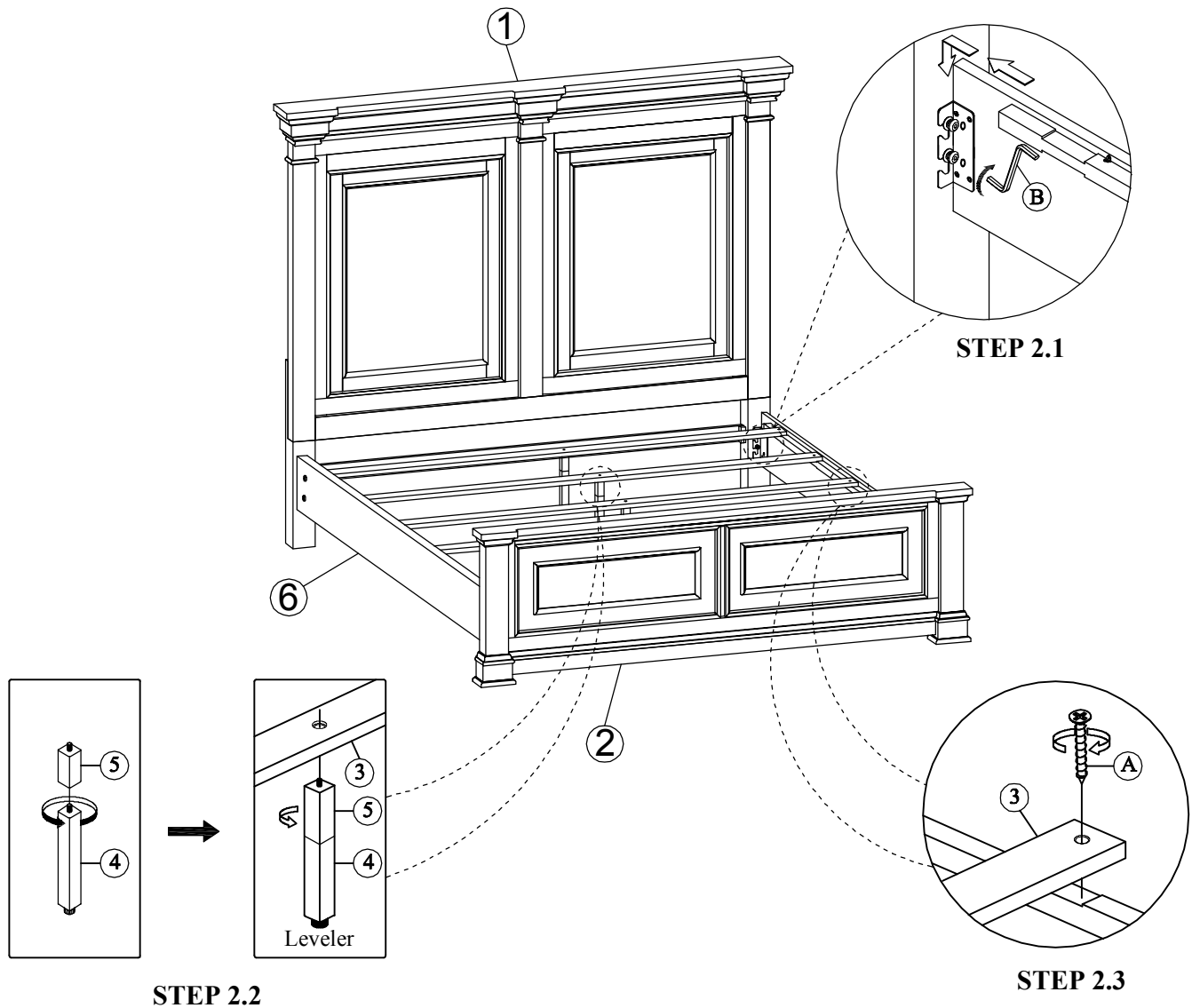

Hardware Pack Location (s): Bolts pack at footboard/ Bolts pack at rails

Queen Bed SKU# 32333635/ 32733633/ 32933637