

**(5532/5534-122) COTTAGE MASTER COLLECTION EKING PANEL BED ASSEMBLY INSTRUCTIONS**

THANK YOU FOR YOUR PURCHASE !

PLEASE CONTACT YOUR RETAIL STORE WITH SERVICE OR PARTS REPLACEMENT REQUEST

READ ALL THE INSTRUCTIONS AND IDENTIFY ALL COMPONENTS AND CHOOSE YOUR CONFIGURATION AND BE SURE YOU HAVE ALL PARTS

TWO PEOPLE ARE NEEDED TO ASSEMBLE.

DO NOT COMPLETELY TIGHTEN ALL BOLTS UNTIL ALL COMPONENTS ARE CONNECTED.

**EKING PANEL BED CONFIGURATION**

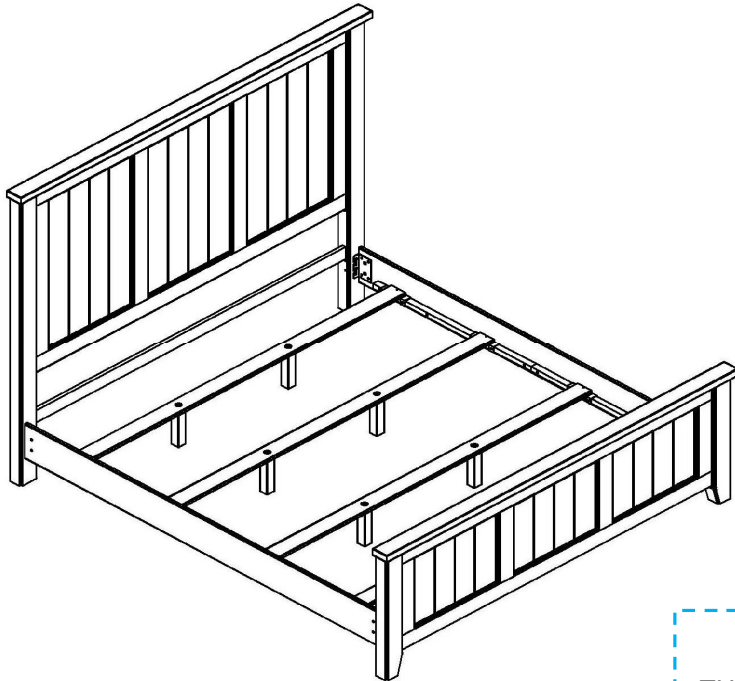

**5532 EKING PANEL BED**

32455328	5532121	EKING PANEL BED HEADBOARD
32855326	5532122	EKING PANEL BED FOOTBOARD
32955328	5532771	SIDE RAILS

**5534 EKING PANEL BED**

32455342	5534121	EKING PANEL BED HEADBOARD
32855340	5534122	EKING PANEL BED FOOTBOARD
32955342	5534771	SIDE RAILS

**WARNING:**

THE BED SLATS WILL NO SUPPORT A MATTRESS ALONE,  
THIS BED REQUIRES A BOX SPRING.  
SOLD SEPARATELY.

**TO ASSEMBLE THIS  
PANEL BED REQUIRES  
TWO PEOPLE**

**TIPS: SEE ILLUSTRATION  
BELOW**

**MAKE SURE ALL BOLTS  
ARE TIGHTENED  
COMPLETELY**

1.- USE THE LONG END OF THE ALLEN WRENCH TO  
FASTEN BOLTS LOOSELY AND QUICKLY.

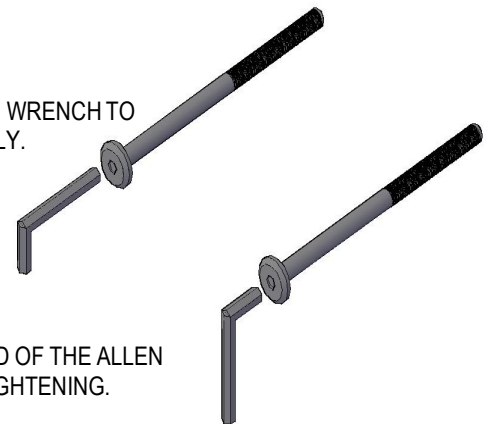

2.- USE THE SHORT END OF THE ALLEN  
WRENCH FOR FINAL TIGHTENING.

**TOOLS NEEDED**

PHILIPS HEAD SCREWDRIVER (NOT INCLUDED)  
4MM ALLEN WRENCH (INCLUDED)

**LIST OF CONTENTS**

**5532/5534-121 E KING PANEL HEADBOARD**

FIG.1- HEADBOARD (1)

**5532/5534-122 E KING PANEL FOOTBOARD**

FIG.2- FOOTBOARD (1)

FIG.3- WOOD SLATS (4)

FIG.4- 7 3/4" SUPPORT LEGS (8)

FIG.5- 3 1/2" SUPPORT LEGS (8)

HARDWARE PACK (HPK00136-0)

FIG.6- 1 1/4" SCREWS (8)

FIG.7- 4MM ALLEN WRENCH (1)

**5532/5534-771 SIDE RAILS**

FIG.8.- SIDE RAILS (2)

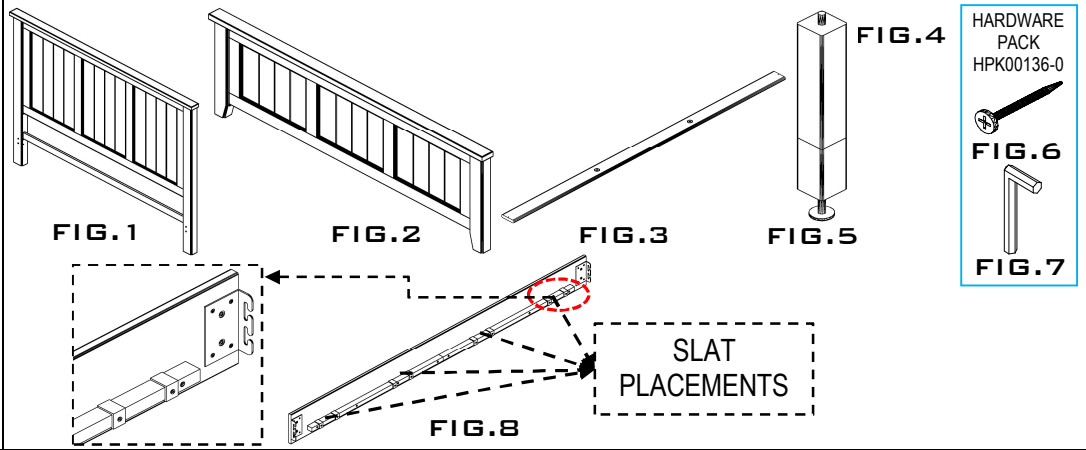

**THERE ARE TWO POSSIBLE SETTINGS HIGH AND LOW CHOOSE ONE, SEE FIG.9**

- 1.- PLACE HEADBOARD (FIG.1) & FOOTBOARD (FIG.2) AND ONE SIDE RAIL ((FIG.8) IN DESIRED POSITION, LOOSE THE PRE - INSTALLED BOLTS IN HDBD & FTBD **SEE FIG.10** TO ALLOW THE BRACKETS IN THE SIDE RAIL TO SLIDE IN AND PUSH DOWN, **SEE FIG.11** THEN TIGHT.
- 2.- REPEAT THE PROCESS FOR THE SECOND RAIL.
- 3.- ATTACH CENTER SUPPORT LEGS TO THE WOOD SLATS (FIG. 3) INSERTING THE SCREW BOLT INSTALLED IN THE SUPPORT LEG (FIG. 4) THEN TIGHT, PLACE ALL WOOD SLATS ON CLEAT SIDE RAIL (**FIG.12**), THEN EACH SLAT MUST BE FASTEN WITH TWO 1 1/4" SCREWS (FIG.6), **SEE FIG.13**

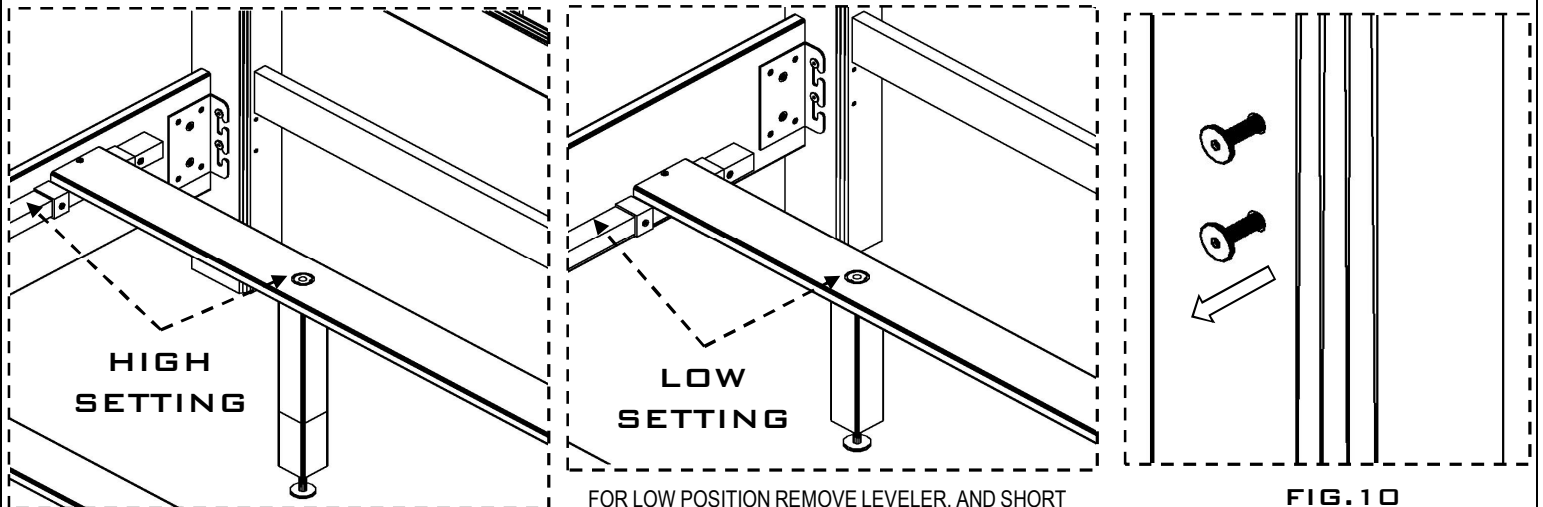

FOR LOW POSITION REMOVE LEVELER, AND SHORT PART OF THE CENTER SUPPORT LEG, THEN INSTALL BACK LEVELER TO THE LONG PART.

