

Assembly Instructions

HMIS B9500-04 KG HDBD

SKU # 32495031

HMIS B9500-05 KG FTBD

SKU # 32895039









HMIS B9500-03/06 QNKG RAILS



SKU # 32995031

This product is manufactured by HMIS for

ROOMS TO GO ▶

***Caution: Please read all instructions carefully before starting the assembly process. These parts are cumbersome and heavy. Therefore, two people are recommended in order to prevent personal injury and ensure the parts are not damaged during the assembly.

Code	Parts List		
1	Headboard		1Pc
2	Left Headboard Leg		1Pc
3	Right Headboard Leg		1Pc
4	Stretcher Rail		1Pc
5	Rails		1Set
6	Slats		4Pcs
7	Support Legs		8Pcs
8	Footboard		1Pc

Step	Code	Hardware List		
1-2-3-4	A	Allen Key - 4mm		1Pc
6	B	Screw - #8x32mm		8Pcs

TOOLS REQUIRED (NOT PROVIDED)	
Description	Sketch
Phillips screwdriver	

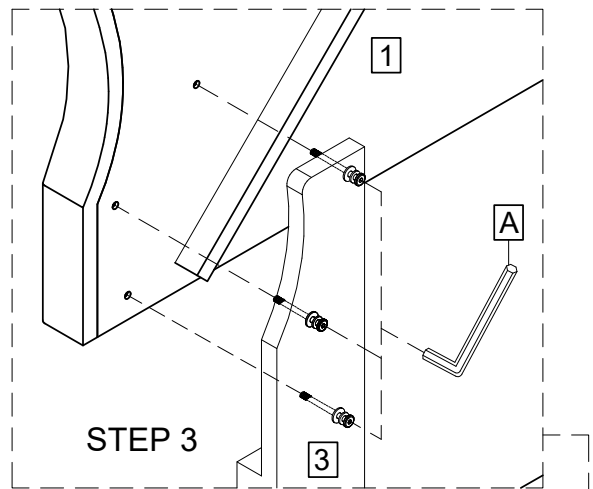
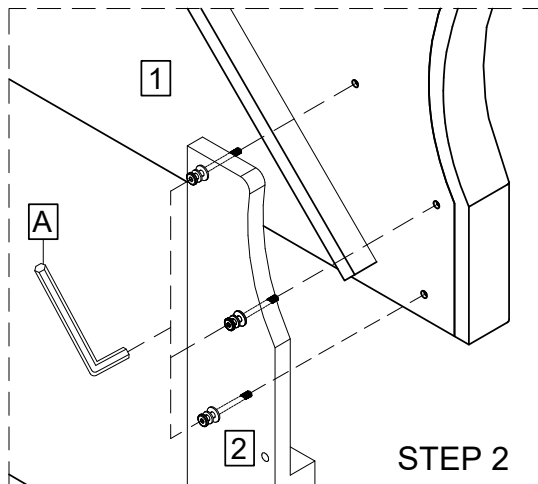

NOTE: The Headboard and Footboard bolts are already pre-installed.

STEP 1 : Assembly Stretcher rail (4) with HB legs using allen key (A). Do not tighten all bolts until HB is fully assembly.

STEP 2 : Assembly the left legs(2) with the left HB(1) using allen key (A). Do not tighten all bolts until HB is fully assembly.

STEP 3 : Assembly the right legs(3) with the right HB(1) using allen key (A).

Do not tighten all bolts until HB is fully assembly.

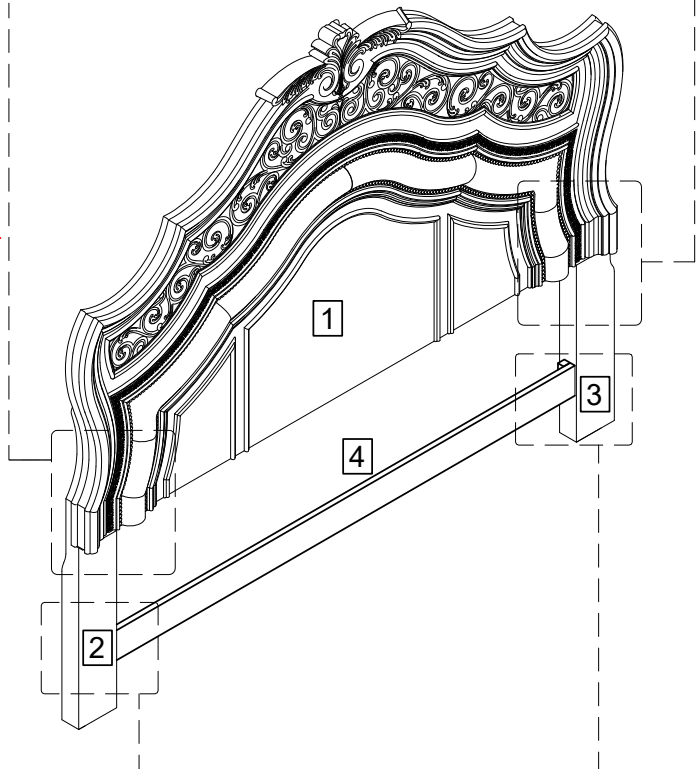
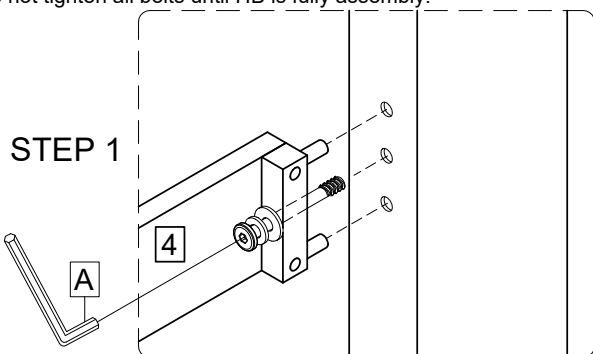

Hardware Pack Location(S):

HMIS B9500-04&03/06 KG HDBD & QNKG RAILS

SKU # 32495031/32995031

MADE IN VIETNAM

1 OF 2

Assembly Instructions

HMIS B9500-04 KG HDBD

SKU # 32495031

HMIS B9500-05 KG FTBD

SKU # 32895039

HMIS B9500-03/06 QNKG RAILS

SKU # 32995031

This product is manufactured by HMIS for

ROOMS TO GO ▶

***Caution: Please read all instructions carefully before starting the assembly process. These parts are cumbersome and heavy. Therefore, two people are recommended in order to prevent personal injury and ensure the parts are not damaged during the assembly.

STEP 4: Assemble the side rails to the HB(1) and FB(8) using allen key (A).

STEP 5: Assemble the support leg(7) to slats(6).

STEP 6: Assemble the slats (6) to the side rail (5).

STEP 4

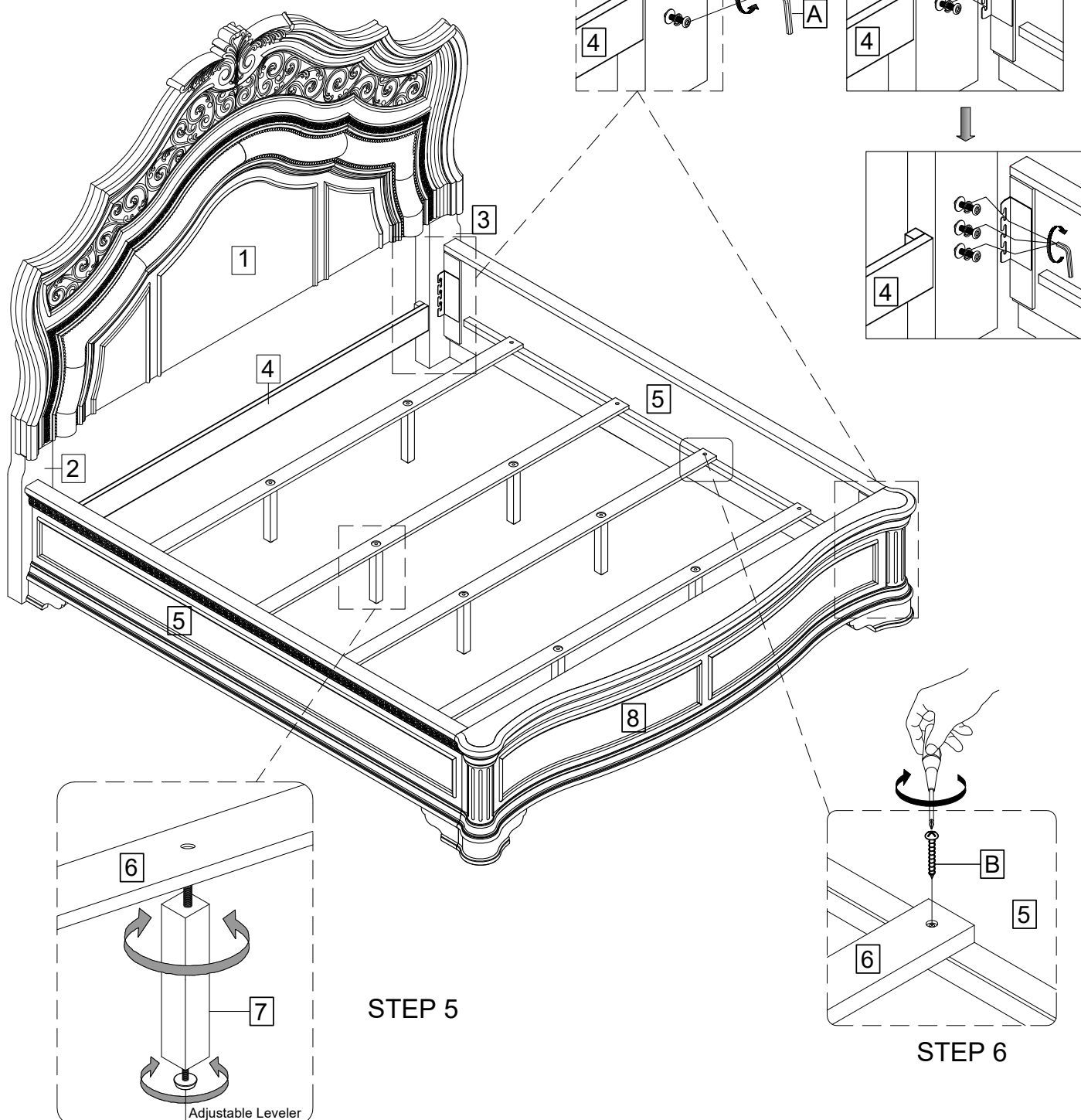

STEP 5

STEP 6