

1) REMOVE HARDWARE BOX CONTAIN METAL BASE AND METAL HANDLES

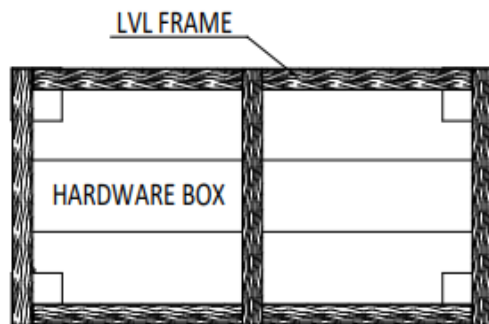

2) ALIGN AND INSERT THE UPRIGHTS INTO THE CROSSBAR AS SHOWN IN "PIC A". YOU SHOULD HEAR A SMALL "CLICK" WHEN THE PIN ALIGNS WITH THE PROPER HOLE.

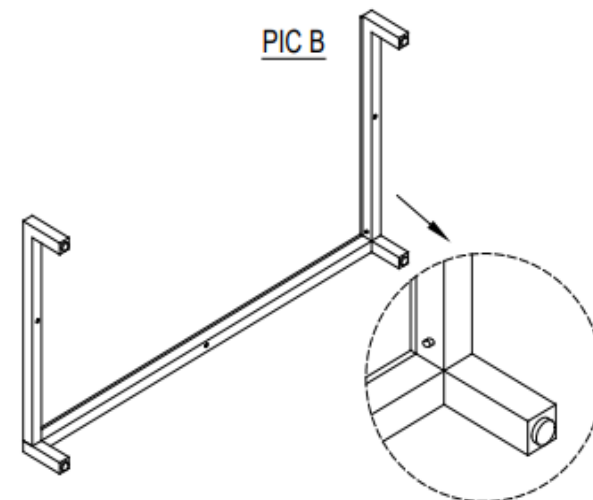
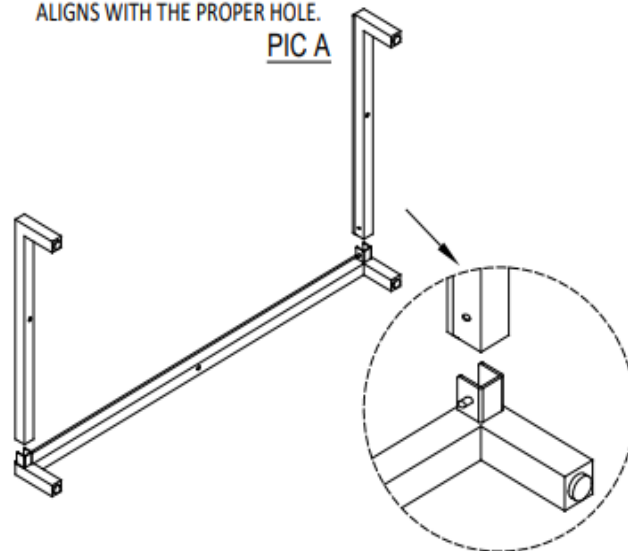

PIC C

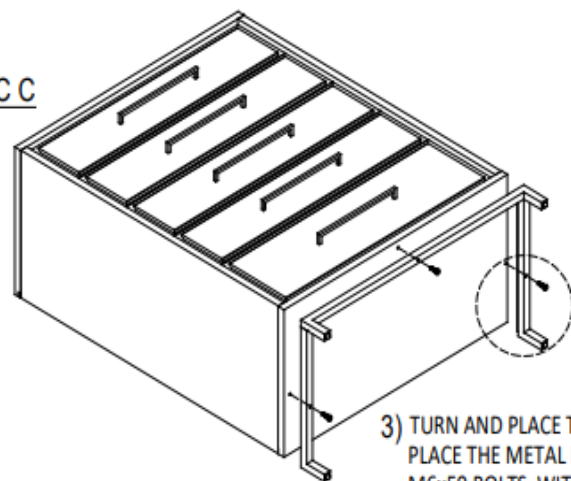

BOLTS TP  
M6x50

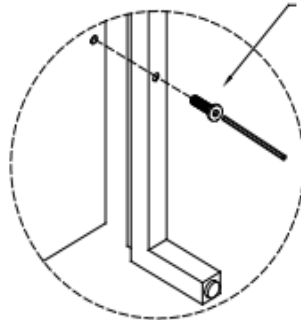

3) TURN AND PLACE THE BACK OF THE CHEST ON THE FLOOR. PLACE THE METAL BASE AT THE BOTTOM OF THE CHEST AND FIX IT WITH n°3 TP M6x50 BOLTS WITH ALLEN WRENCH AS SHOWN IN "PIC C"

PIC D

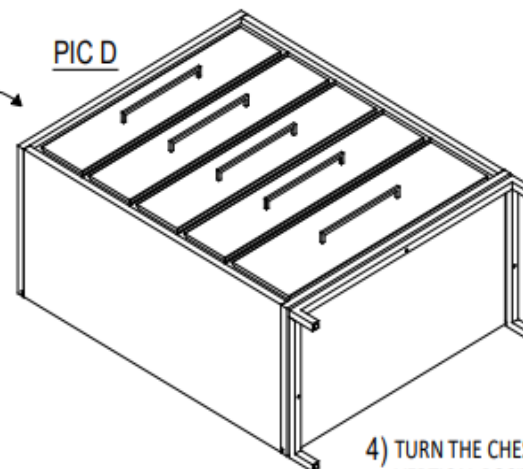

4) TURN THE CHEST IN VERTICAL POSITION

**PARTS LIST**



n° 1 CHEST METAL CROSS

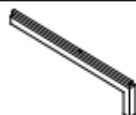

n° 1 RIGHT UPRIGHT



n° 1 LEFT UPRIGHTS

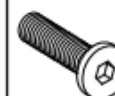

n° 3 BOLTS TP M6x50



n° 1 ALLEN WRENCH