







Thank you for purchasing this quality product. Be sure to check all packing materials carefully for small parts, which may have come loose inside the carton during shipment. Identify and count all parts and compare with the **HARDWARE LIST** below.

Caution: Please read instructions thoroughly before unpacking assembly parts.

1. We recommend that you assemble this product with the assistance of another person; this will make assembly easier, and will help to eliminate damage to the product or injury to persons during assembly.
2. Please put all parts on a non-abrasive floor before assembly, and follow the assembly steps to assemble your newly purchased product correctly and efficiently.
3. Do not tighten all bolts until the assembly is completed.

NO.	HARDWARE LIST		Q' TY
1		ALLEN KEY (L57 * 4MM)	1
2		BOLT Ø5/16"-18*42MM(L) (PRE-ASSEMBLED)	9
		SPRING WASHER Ø5/16"-13MM (PRE-ASSEMBLED)	9
		FLATWASHER Ø5/16"-19MM*2MM(T) (PRE-ASSEMBLED)	9
		T-NUT BUSHING 1/4"* L10*Ø17 (PRE-ASSEMBLED)	9
3		SCREW M4 * 1-1/2"	4

NO.	PARTS LIST		Q' TY
A		Seat Frame	1
B		Side leg	2
C		Middle Leg (LEVELER)	1
D		Stretcher	2

STEP: 1

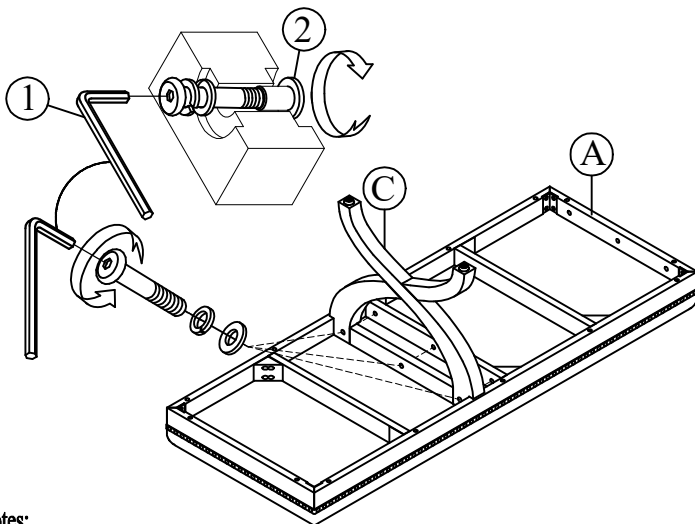

Notes:
The bolts are pre-assembled

Attach the middle leg to the Seat Frame

STEP: 2

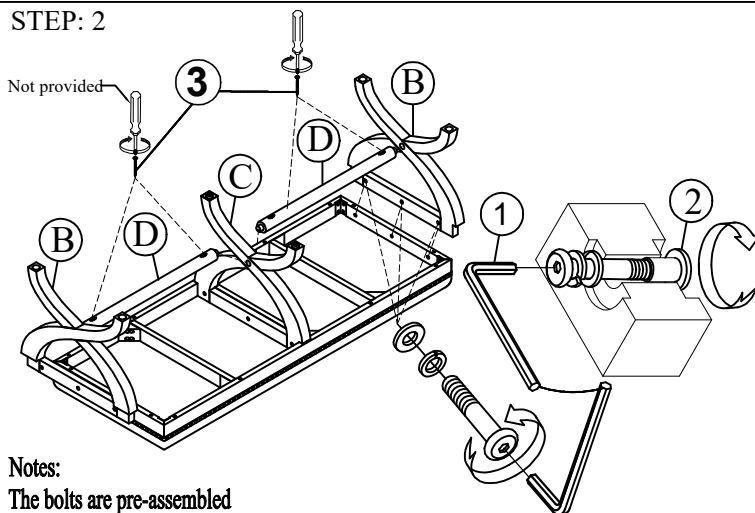

Notes:
The bolts are pre-assembled

Attach the Stretcher to middle leg then attach Side leg to the Seat Frame and the Stretcher

COMPLETED

