

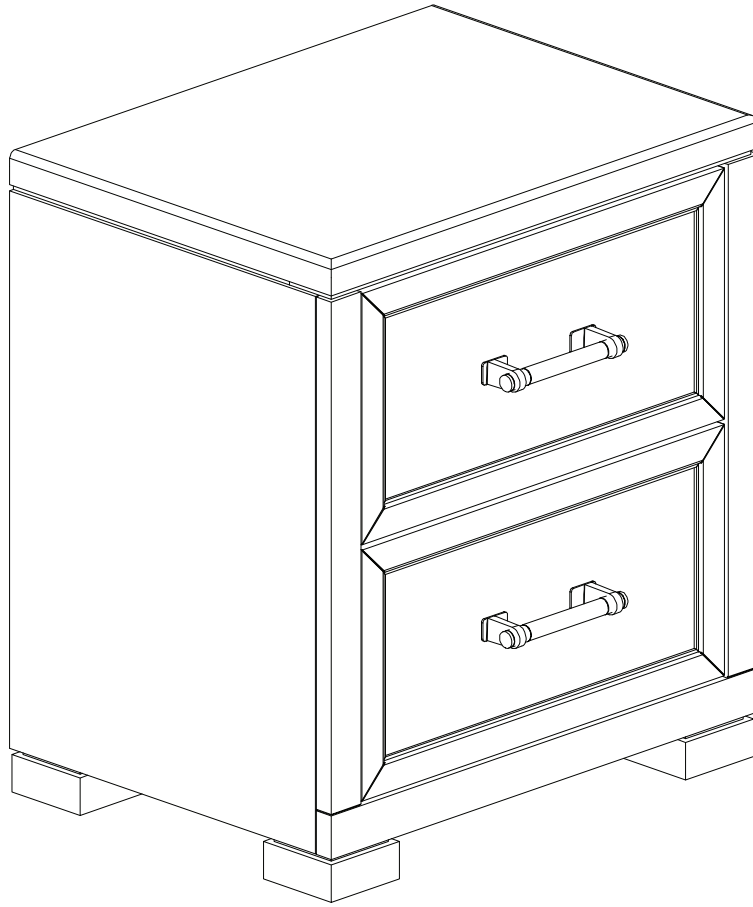

# CARBON OPTIX

## NIGHTSTAND

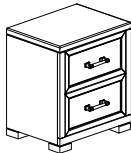

NIGHTSTAND - PAINTED BLACK		
RTG SKU #	STYLE #	ITEM DESCRIPTION
35571810	7181-773	NIGHTSTAND

NIGHTSTAND PART LIST			
	ITEM DESCRIPTION	IMAGE	QTY
A	NIGHTSTAND		1 PC
B	FURNITURE TIPPING RESTRAINT (Customer To Assemble)		1 SET
C	PHILIPS HEAD SCREWDRIVER (NOT PROVIDED)		1 PC

DO NOT USE SUBSTITUTE PARTS. PLEASE CONTACT YOUR RETAIL STORE OR [WWW.ROOMSTOGO.COM](http://WWW.ROOMSTOGO.COM)  
WITH SERVICE OR PARTS REPLACEMENT REQUEST

This product is manufactured by (HILB) for ROOMS TO GO | KIDS  
Version #4 - 2023/11/29

Thank you for purchasing this quality product. Be sure to check all packing material carefully for small parts which may have come loose inside the carton during shipment. Identify and count all parts and compare with the parts list below. Read all instructions before assembling and keep these instructions for future reference.

## Assembly Instructions:

### STEP 1

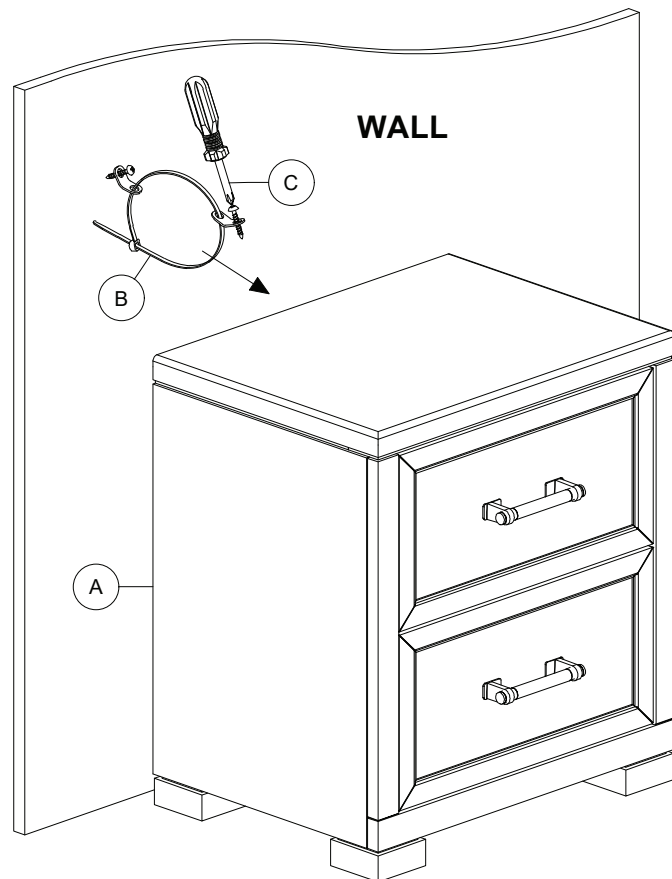

To prevent the Nightstand (A) from tipping, mount one side of the Tipping Restraint (B) to the backside of the Nightstand (A) and the other side to the wall.

DO NOT USE SUBSTITUTE PARTS. PLEASE CONTACT YOUR RETAIL STORE OR [WWW.ROOMSTOGO.COM](http://WWW.ROOMSTOGO.COM) WITH SERVICE OR PARTS REPLACEMENT REQUEST

This product is manufactured by (HILB) for ROOMS TO GO | KIDS  
Version #4 - 2023/11/29

# Wooden Furniture Care

## Protect Your Investment

The beauty of furnishing care is that it helps to protect your investment. Fine furniture is an important purchase. Proper care will help maintain your furniture's finish and ensure that it looks great year after year.

## Caring For Furniture

Caring for furniture is easy. Following a few simple guidelines will help extend the life of your furniture.

\*Always dust with a polish moistened cloth. Polish cushions the cloth, eliminating the scratching that occurs with dry dusting. Dust will scratch the furniture surface if not removed quickly. Use a soft, clean cloth that won't scratch the surface. Avoid coarse or scratchy materials or fabrics

\*Avoid using soap and water on furniture. Water can penetrate the finish and raise the grain on wood, causing damage.

## The Enemies of Furniture

Many common problems in furniture care are caused by the elements. If you are aware of these troublemakers, the resulting damage can easily be avoided.

\*Sunlight's ultraviolet rays can damage wood finishes. Arrange furniture out of direct sunlight, use sun screening drapes during intense sunlight hour, rotate furniture in place and in room arrangements.

\*Liquid spills will damage furniture if not removed promptly. Use coasters under beverage glasses saucers under cups and flowerpots. If a spill occurs, immediately blot it gently without rubbing the surface.

\*Heat creates a chemical change in the furniture finish. Which can result in a white spot. Use protective pads under hot dishes, utensils or cooking appliances.

\*Cyclic changes in temperature can damage furniture. I-lot blasts of air such as those found from central heating should be avoided because they cause extreme localized drying of the wood.

## Tips for Better Dusting

\*Be sure in use the sauce type of polish consistently. Your furniture will appear cloudy or streaky if oil based and wax-based polished are interchanged.

\*Always use a fine furniture polish when dusting. Never dry dust, as it could cause microscopic scratches on your furniture surface. Remember to change dusting clothes frequently since a dirty cloth may scratch your furniture's surface.

\*Spray your furniture surface evenly, but not too generously. Wipe in a circular motion with a soft, clean cloth to clean and loosen the old polish.

\*Then, buff until completely dry for a beautiful shine and a smudge-resistant finish. For wood trim, spray polish on the cloth first, and then dust.