

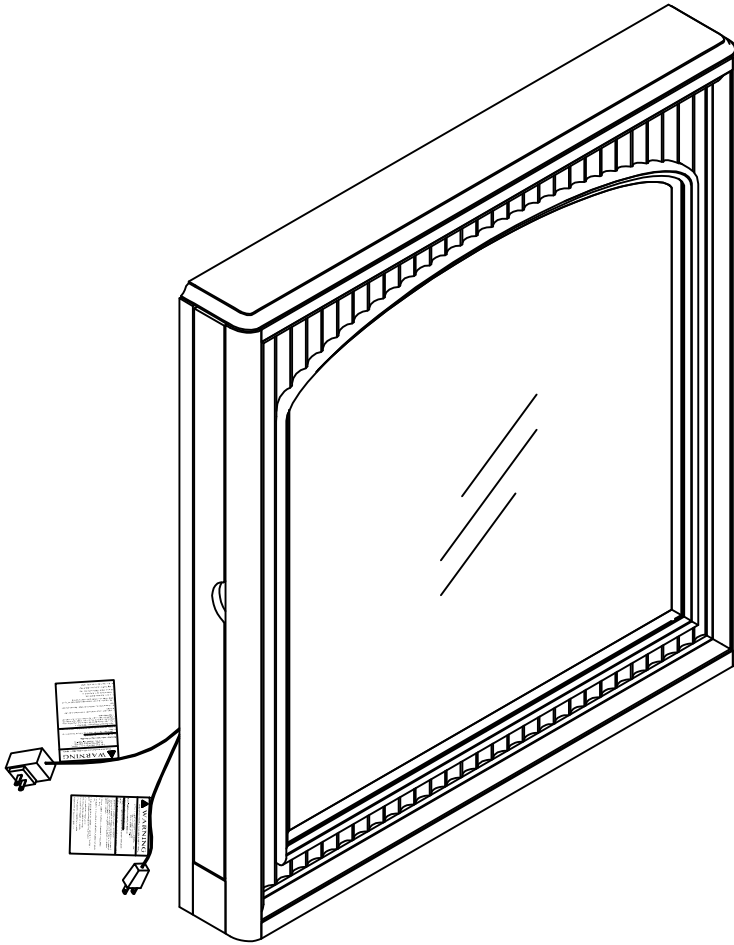

VIVIEN MIRROR



SKU #	ITEM#	COLOR	ITEM DESCRIPTION
36026878	2687-04R	WIREBRUSH GRAY	MIRROR

MIRROR PARTS LIST			
A	Mirror		1PC
B	Mirror Support		2PCS

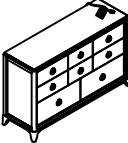
PARTS REQUIRED			
C	Drawer Dresser (Sold Separately)		1PC

This product is manufactured by HOUS for **ROOMS TO GO®** | **KIDS**

DO NOT USE SUBSTITUTE PARTS. PLEASE CONTACT YOUR RETAIL STORE OR WWW.ROOMSTOGO.COM
WITH SERVICE OR PARTS REPLACEMENT REQUEST

VIVIEN MIRROR

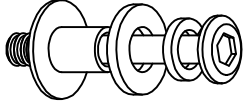
MIRROR HARDWARE LIST			Q'TY
1	Allen key 4*74*29mm		1PC
2	Bolt 5/16"-10*1-3/16" (PRE-ASSEMBLED) Spring washer 5/16" (PRE-ASSEMBLED) Flat washer 5/16" (PRE-ASSEMBLED) Threaded Washer 5/16" (PRE-ASSEMBLED)		8PCS

Hardware Pack Location(s):

SKU #	ITEM#	COLOR	ITEM DESCRIPTION
36026878	2687-04R	WIREBRUSH GRAY	MIRROR

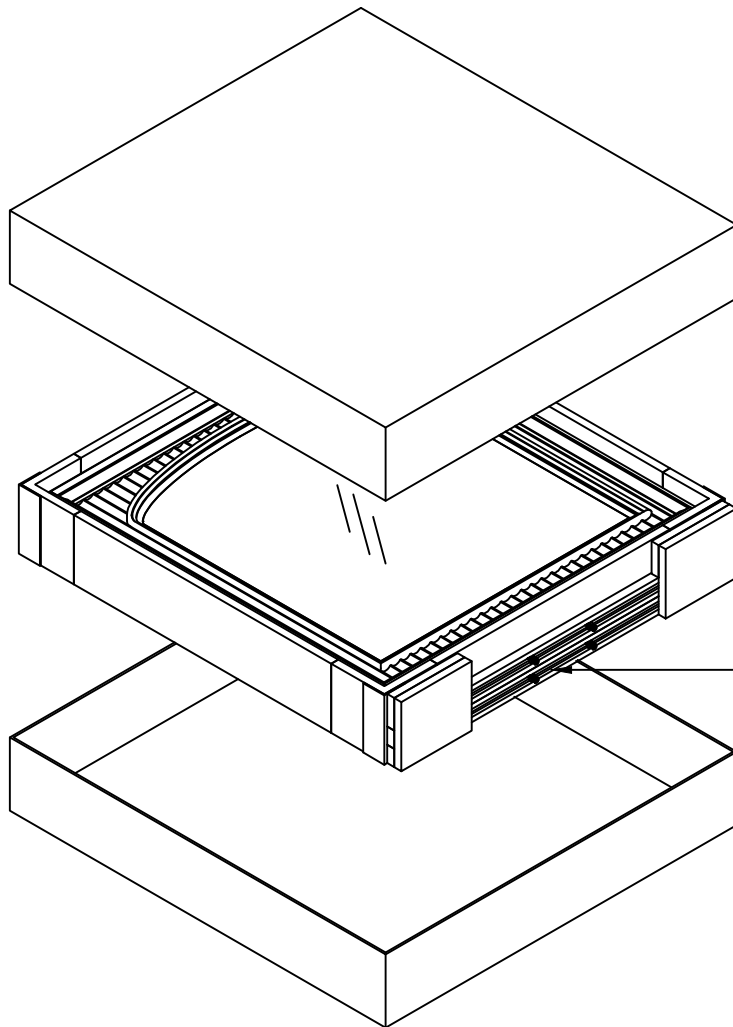

MIRROR BOX

HARDWARE PACKAGE HERE

This product is manufactured by HOUS for ROOMS TO GO® | KIDS

DO NOT USE SUBSTITUTE PARTS. PLEASE CONTACT YOUR RETAIL STORE OR WWW.ROOMSTOGO.COM
WITH SERVICE OR PARTS REPLACEMENT REQUEST

ASSEMBLY INSTRUCTION

***Caution: Please read all instructions carefully before starting the assembly process. These parts are cumbersome and heavy. Therefore, two people are recommended in order to prevent personal injury and ensure the parts are not damaged during the assembly.

Remark: The bolts (2) were pre-installed on the mirror support.

Step 1: With another person's assistance, lay the mirror (A) on the top of the dresser (C), attach mirror support (B) into position to secure the mirror in place by using allen key (1) tighten the bolts.

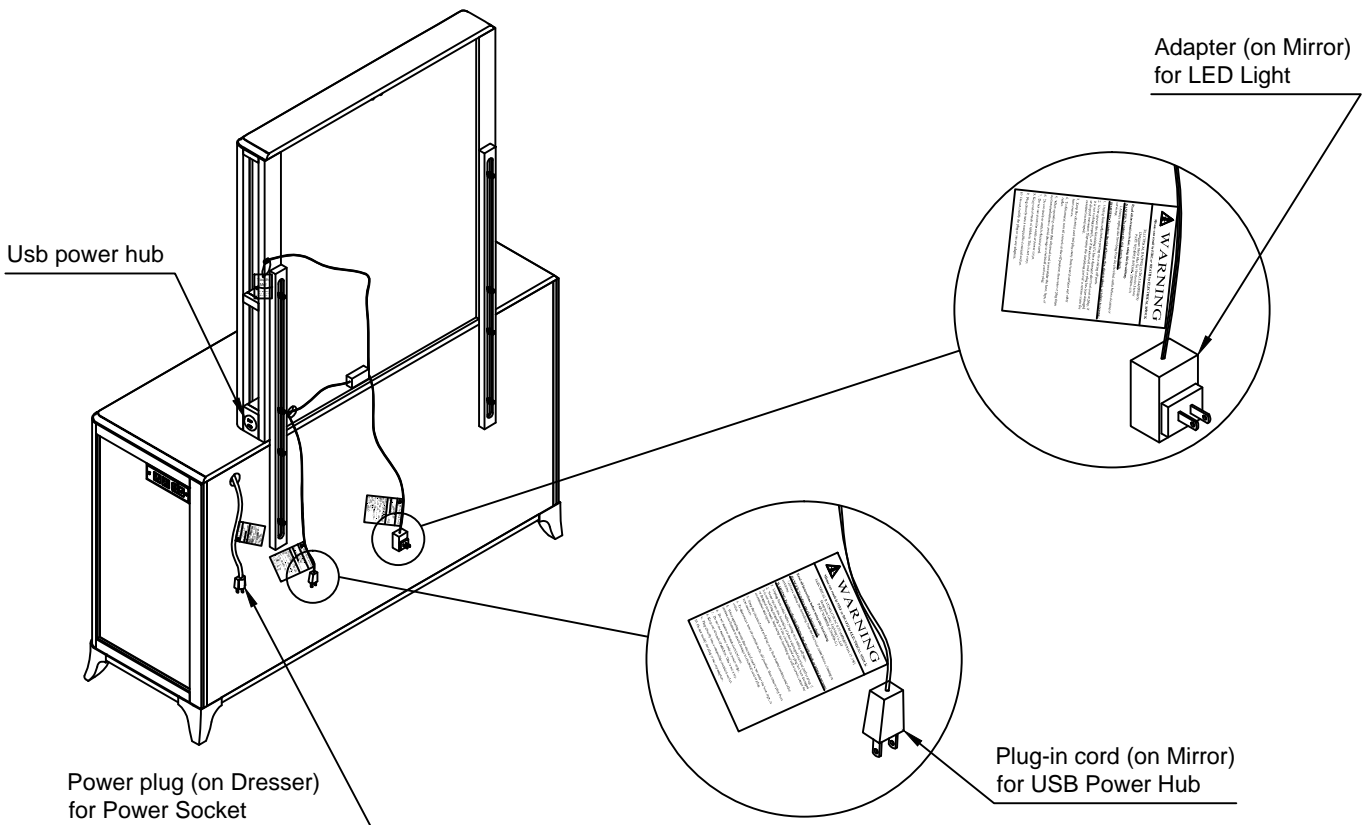
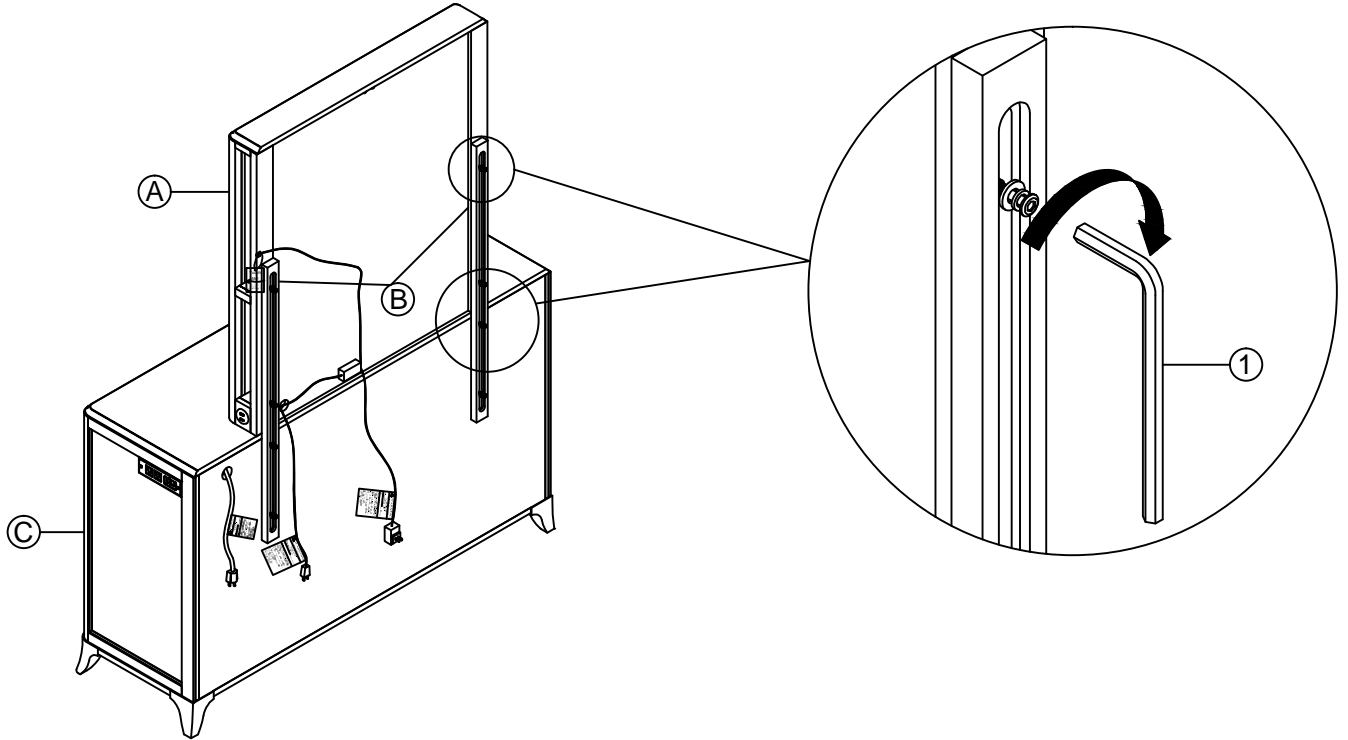

This product is manufactured by HOUS for ROOMS TO GO® | KIDS

DO NOT USE SUBSTITUTE PARTS. PLEASE CONTACT YOUR RETAIL STORE OR WWW.ROOMSTOGO.COM WITH SERVICE OR PARTS REPLACEMENT REQUEST

ASSEMBLY INSTRUCTION

***Caution: Please read all instructions carefully before starting the assembly process. These parts are cumbersome and heavy. Therefore, two people are recommended in order to prevent personal injury and ensure the parts are not damaged during the assembly.

Front of Hang Tag

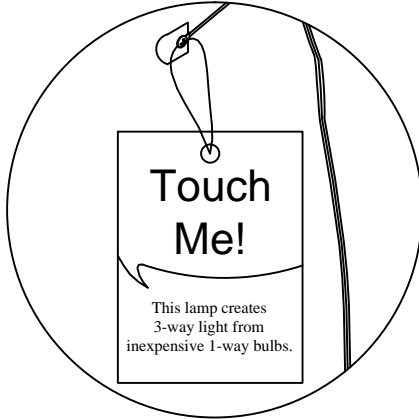

Back of Hang Tag

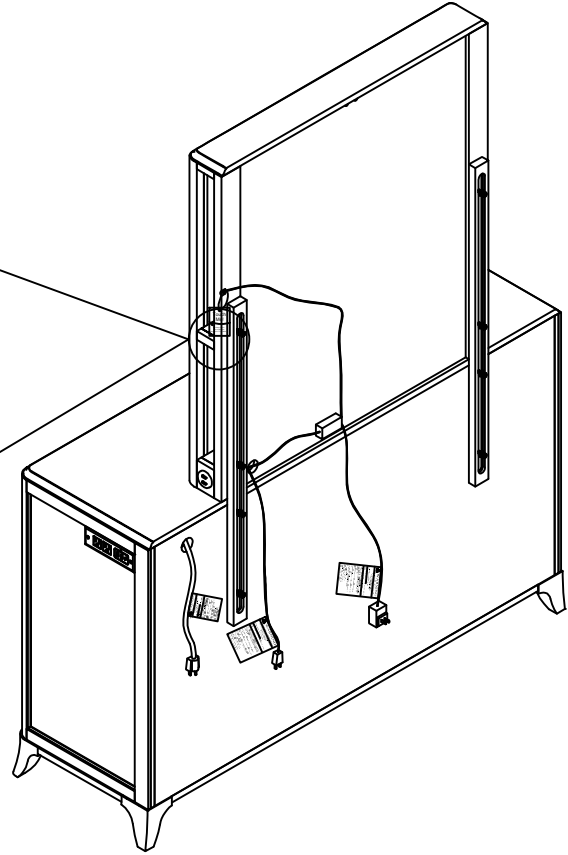
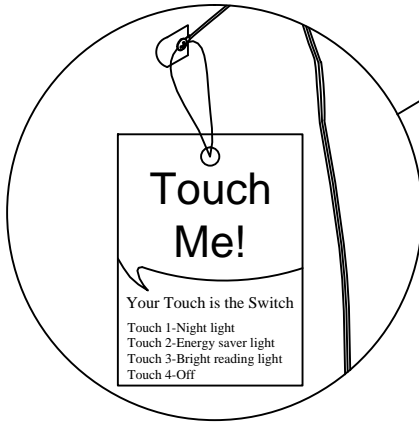

Jewelry Hangers

Jewelry Box

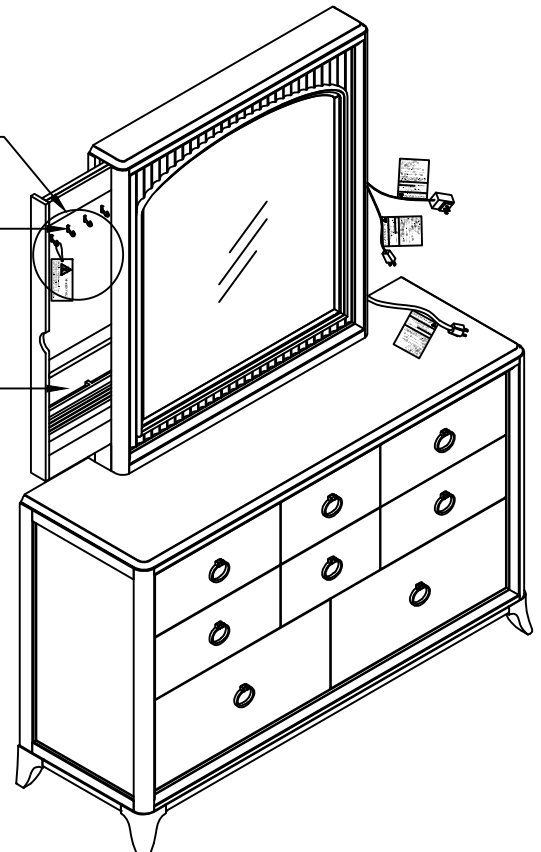

This product is manufactured by HOUS for ROOMS TO GO® | KIDS

DO NOT USE SUBSTITUTE PARTS. PLEASE CONTACT YOUR RETAIL STORE OR WWW.ROOMSTOGO.COM WITH SERVICE OR PARTS REPLACEMENT REQUEST

IMPORTANT SAFETY INSTRUCTIONS



WARNING

Misuse can result in FIRE or DEATH by ELECTRICAL SHOCK

ELECTRICAL RATING(100-240VAC/Max. 0.6AMPERES)
DONG GUAN CITY HUGE SUN LIGHTING CO.,LTD.
PART NUMBER (CH005B-AC30)

Read all instructions before using this furnishing.

DANGER-To reduce the risk electric shock

1. Always unplug this furnishing from the electrical outlet before cleaning or servicing.

WARNING-To reduce the risk of burns, fire, electric shock, or injury to persons:

1. Unplug from outlet before putting on or taking off parts.
2. Never operate this furnishing if it has a damaged electrical cord or plug, if it is not working properly, or if the electrical cord or plug has been damaged or dropped into water. Stop using this furnishing and call a service center for examination and repair.
3. Keep the electrical cord and plug away from heated surfaces and other heat sources.
4. To disconnect, turn all controls to the off position, then remove plug from outlet.
5. When operating, ensure that electrical cord is not under the base, legs, or motion mechanism to avoid damage to electrical cord or plug.
6. Do not strain or stretch electrical cord.
7. Do not use extension cords or power strips.
8. Keep out of reach of children. This is not a toy.
9. Plug directly into a compatible electrical socket.
10. Do not modify the plug or use any adapters.

INSTRUCCIONES DE SEGURIDAD IMPORTANTES



WARNING

El mal uso puede INCENDIO o MUERTE por DESCARGA ELÉCTRICA

CLASIFICACION ELECTTRICA(100-240VAC/Max. 0.6AMPERES)
DONG GUAN CITY HUGE SUN LIGHTING CO.,LTD.
PART NUMBER (CH005B-AC30)

Leer todas las instrucciones antes de usar este mobiliario.

PELIGRO-Para reducir el riesgo de descarga electrica:

1. Siempre desenchufe este accesorio de la toma de corriente eléctrica antes de limpiarlo o repararlo.

ADVERTENCIA: para reducir el riesgo de quemaduras, incendios, descargas eléctricas o lesiones a personas:

1. Desenchufe del tomacorriente antes de colocar o quitar partes.
2. Nunca opere este accesorio si tiene un cable o enchufe eléctrico dañado, si no funciona correctamente, o si el cable o el enchufe eléctrico se ha dañado o se ha caído al agua. Deje de usar este equipamiento y llame a un centro de servicio para que lo examinen y lo reparen.
3. Mantenga el cable eléctrico y el enchufe lejos de superficies calientes y otras fuentes de calor.
4. Para desconectar, gire todos los controles a la posición de apagado, luego retire el enchufe del tomacorriente.
5. Al operar, asegúrese de que el cable eléctrico no esté debajo de la base, las patas o el mecanismo de movimiento para evitar dañar el cable eléctrico o el enchufe.
6. No fuerce ni estire el cable eléctrico.
7. No utilizar cables de extensión o tomas de corriente.
8. Mantener fuera del alcance de los niños. Esto no es un juguete.
9. Enchúfelo directamente a una toma de corriente compatible.
10. No modifique el enchufe ni utilice adaptadores.

IMPORTANT SAFETY INSTRUCTIONS



WARNING

Misuse can result in FIRE or DEATH by ELECTRICAL SHOCK

ELECTRICAL RATING(12VDC/2.0AMPERES)
X.L.Y ELECTRONICS CO.,LTD
PART NUMBER (W24 -120200UW)

Read all instructions before using this furnishing.

DANGER-To reduce the risk electric shock

1. Always unplug this furnishing from the electrical outlet before cleaning or servicing.

WARNING-To reduce the risk of burns, fire, electric shock, or injury to persons:

1. Unplug from outlet before putting on or taking off parts.
2. Never operate this furnishing if it has a damaged electrical cord or plug, if it is not working properly, or if the electrical cord or plug has been damaged or dropped into water. Stop using this furnishing and call a service center for examination and repair.
3. Keep the electrical cord and plug away from heated surfaces and other heat sources.
4. To disconnect, turn all controls to the off position, then remove plug from outlet.
5. When operating, ensure that electrical cord is not under the base, legs, or motion mechanism to avoid damage to electrical cord or plug.
6. Do not strain or stretch electrical cord.
7. Do not use extension cords or power strips.
8. Keep out of reach of children. This is not a toy.
9. Plug directly into a compatible electrical socket.
10. Do not modify the plug or use any adapters.

INSTRUCCIONES DE SEGURIDAD IMPORTANTES



WARNING

El mal uso puede INCENDIO o MUERTE por DESCARGA ELÉCTRICA

CLASIFICACION ELECTTRICA(12VDC/2.0AMPERES)
X.L.Y ELECTRONICS CO.,LTD
PART NUMBER (W24 -120200UW)

Leer todas las instrucciones antes de usar este mobiliario.

PELIGRO-Para reducir el riesgo de descarga electrica:

1. Siempre desenchufe este accesorio de la toma de corriente eléctrica antes de limpiarlo o repararlo.

ADVERTENCIA: para reducir el riesgo de quemaduras, incendios, descargas eléctricas o lesiones a personas:

1. Desenchufe del tomacorriente antes de colocar o quitar partes.
2. Nunca opere este accesorio si tiene un cable o enchufe eléctrico dañado, si no funciona correctamente, o si el cable o el enchufe eléctrico se ha dañado o se ha caído al agua. Deje de usar este equipamiento y llame a un centro de servicio para que lo examinen y lo reparen.
3. Mantenga el cable eléctrico y el enchufe lejos de superficies calientes y otras fuentes de calor.
4. Para desconectar, gire todos los controles a la posición de apagado, luego retire el enchufe del tomacorriente.
5. Al operar, asegúrese de que el cable eléctrico no esté debajo de la base, las patas o el mecanismo de movimiento para evitar dañar el cable eléctrico o el enchufe.
6. No fuerce ni estire el cable eléctrico.
7. No utilizar cables de extensión o tomas de corriente.
8. Mantener fuera del alcance de los niños. Esto no es un juguete.
9. Enchúfelo directamente a una toma de corriente compatible.
10. No modifique el enchufe ni utilice adaptadores.