

(94,95,96-804) CREEKSID COLLECTION FULL/FULL BUNK BED ASSEMBLY INSTRUCTIONS

THANK YOU FOR YOUR PURCHASE !

PLEASE CONTACT YOUR RETAIL STORE FOR SERVICE OR REPLACEMENT PARTS REQUEST

READ ALL THE INSTRUCTIONS AND IDENTIFY ALL COMPONENTS AND CHOOSE YOUR CONFIGURATION AND BE SURE YOU HAVE ALL PARTS

TWO PEOPLE ARE NEEDED TO ASSEMBLE.

DO NOT COMPLETELY TIGHTEN ALL BOLTS UNTIL ALL COMPONENTS ARE CONNECTED.

FULL/FULL BUNK BED

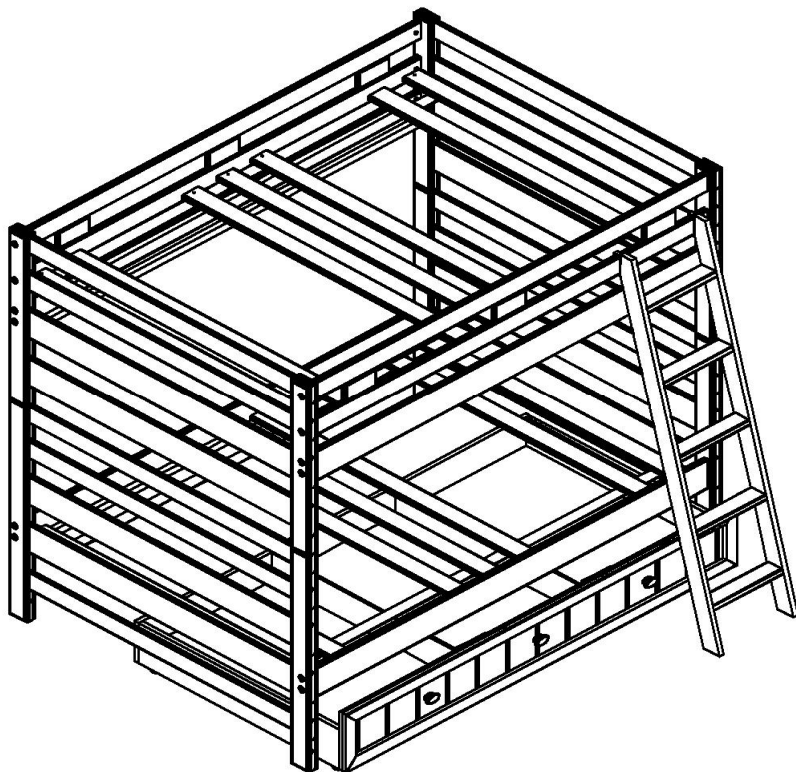

3899401P FULL/FULL BUNK BED (TAFFY)

36794015	94H-804	FULL BUNK END
36794015	94H-804	FULL BUNK END
35794014	94H-730	6 PIECE BUNK RAILS
35894016	94 H-720	LADDER
38200236	100-647	FULL SLAT ROLL
38200236	100-647	FULL SLAT ROLL

3899503P FULL/FULL BUNK BED (CHARCOAL)

36795031	95G-804	FULL BUNK END
36795031	95G-804	FULL BUNK END
35795030	95G-730	6 PIECE BUNK RAILS
35895032	95G-720	LADDER
38200236	100-647	FULL SLAT ROLL
38200236	100-647	FULL SLAT ROLL

3899602P FULL/FULL BUNK BED (STONE WASH)

36796021	96C-804	FULL BUNK END
36796021	96C-804	FULL BUNK END
35796020	96C-730	6 PIECE BUNK RAILS
35896022	96C-720	LADDER
38200236	100-647	FULL SLAT ROLL
38200236	100-647	FULL SLAT ROLL

WARNING:

THE BED SLATS WILL NO SUPPORT A MATTRESS ALONE, A SLAT PACK OR A BUNKIE BOARD IS REQUIRED FOR PROPER SAFETY.

(NOT INCLUDED)

TIPS: SEE ILLUSTRATION BELOW

1.- USE THE LONG END OF THE ALLEN WRENCH TO FASTEN BOLTS LOOSELY AND QUICKLY.

MAKE SURE ALL BOLTS ARE TIGHTENED COMPLETELY

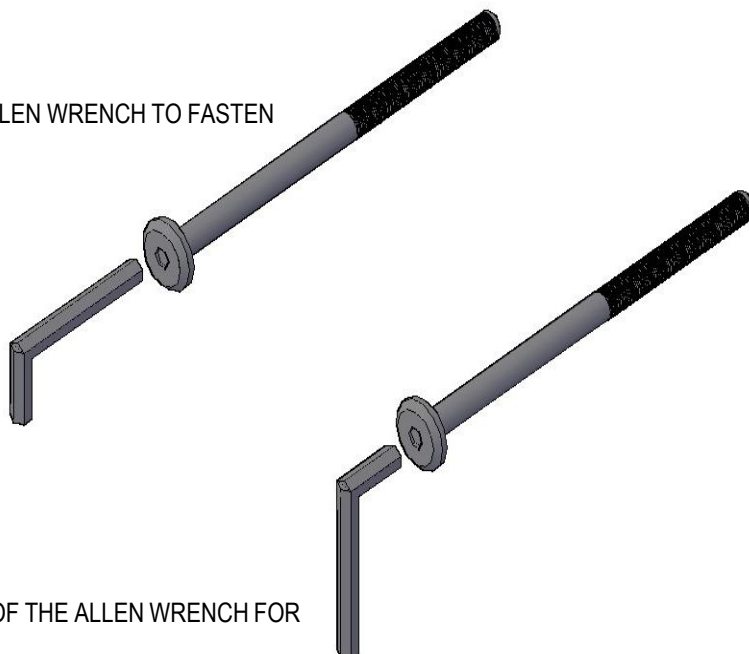

TO ASSEMBLE THIS CONFIGURATION REQUIRES TWO PERSONS

2.- USE THE SHORT END OF THE ALLEN WRENCH FOR FINAL TIGHTENING.

CANYON FURNITURE COMPANY
FULL/FULL BUNK BED ASSEMBLY INSTRUCTIONS CONFIGURATION

LIST OF CONTENTS

94,95,96-804 FULL BUNK END FIG.1 (2 PCS)

- A.- (1) TOP HEADBOARD
- B.- (1) BOTTOM HEADBOARD
- HARDWARE PACK (HPK00121-0)
- C.- (2) 4" METAL DOWEL PINS

94,95,96-730 6 PIECE BUNK RAILS FIG.2

- D.- (4) SIDE RAILS
- E.- (2) GUARD RAILS
- HARDWARE PACK (HPK00093-1)

- F.- (24) 5/16" X 4" HEX TAP BOLTS
- G.- (24) 5/16"-18 X 5/8" CROSS DOWEL NUTS
- H.- (1) 5MM ALLEN WRENCH

100-647 FULL SLAT ROLL FIG.3 (2 PCS)

- I.- (1) SLAT PACK
- HARDWARE PACK (HPK00042-0)
- J.- (14) 1 1/4" SCREWS

94,95,96-744 KD TRUNDLE STORAGE FIG.4

- K.- (1) TRUNDLE BED

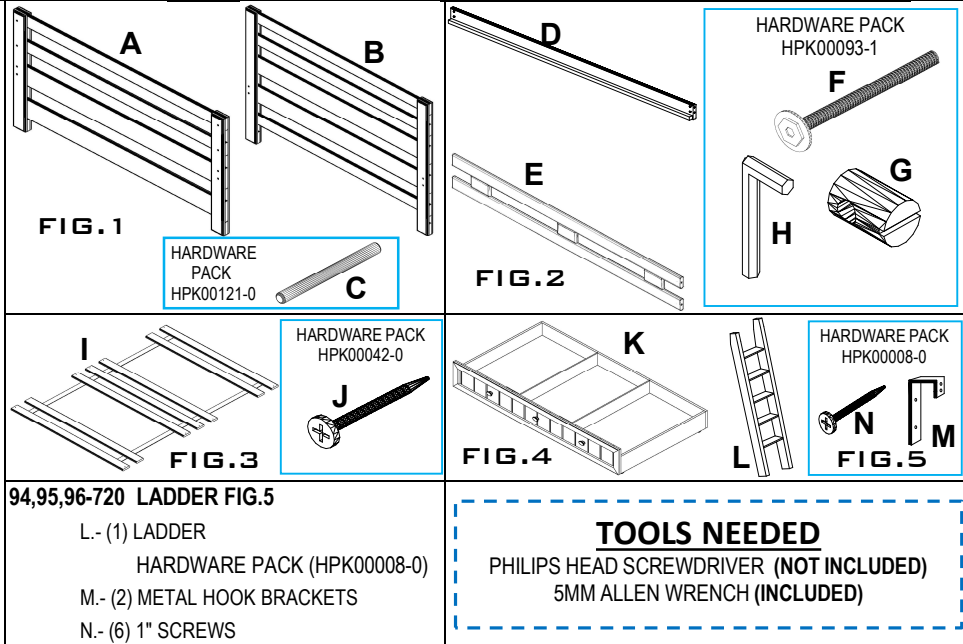

94,95,96-720 LADDER FIG.5

- L.- (1) LADDER
- HARDWARE PACK (HPK00008-0)
- M.- (2) METAL HOOK BRACKETS
- N.- (6) 1" SCREWS

TOOLS NEEDED
 PHILIPS HEAD SCREWDRIVER (NOT INCLUDED)
 5MM ALLEN WRENCH (INCLUDED)

TOP HEADBOARD ASSEMBLY (USE FULL SLAT ROLL 100-647)

- 1.- ASSEMBLE **TOP BUNK BED** BY USING TWO TOP HDBDS (A), TWO SIDE RAILS (D) AND TWO GUARD RAILS (E).
- 2.- INSERT TWO CROSS DOWEL NUTS (G) IN ACCESS HOLE INSIDE THE SIDE RAIL & GUARDRAIL, ALIGN CROSS DOWEL NUT MAKE SURE THE GROOVE IS HORIZONTAL, FIG.A
- 3.- ATTACH TWO SIDE RAILS & TWO GUARD RAILS TO TOP HEADBOARDS, INSERTING TWO HEX TAP BOLTS (F) IN EACH CORNER OF TOP HEADBOARD HOLES, USE THE 5MM ALLEN WRENCH (H) TO TIGHTEN BOTH HEX TAP BOLTS, (DO NOT TIGHTEN COMPLETELY UNTIL ALL PIECES ARE CONNECTED TOGETHER) **SEE FIG.6**, REPEAT THE SAME PROCESS ON ALL FOUR CORNERS.
- 4.- PLACE FULL SLAT ROLL (I) INSIDE THE TOP BUNK BED PUSH SLAT PACK AGAINST THE BED END POST (FIG.B) AND SECURE WITH TWO 1 1/4" SCREWS (J) IN EACH SLAT **SEE FIG.7**.

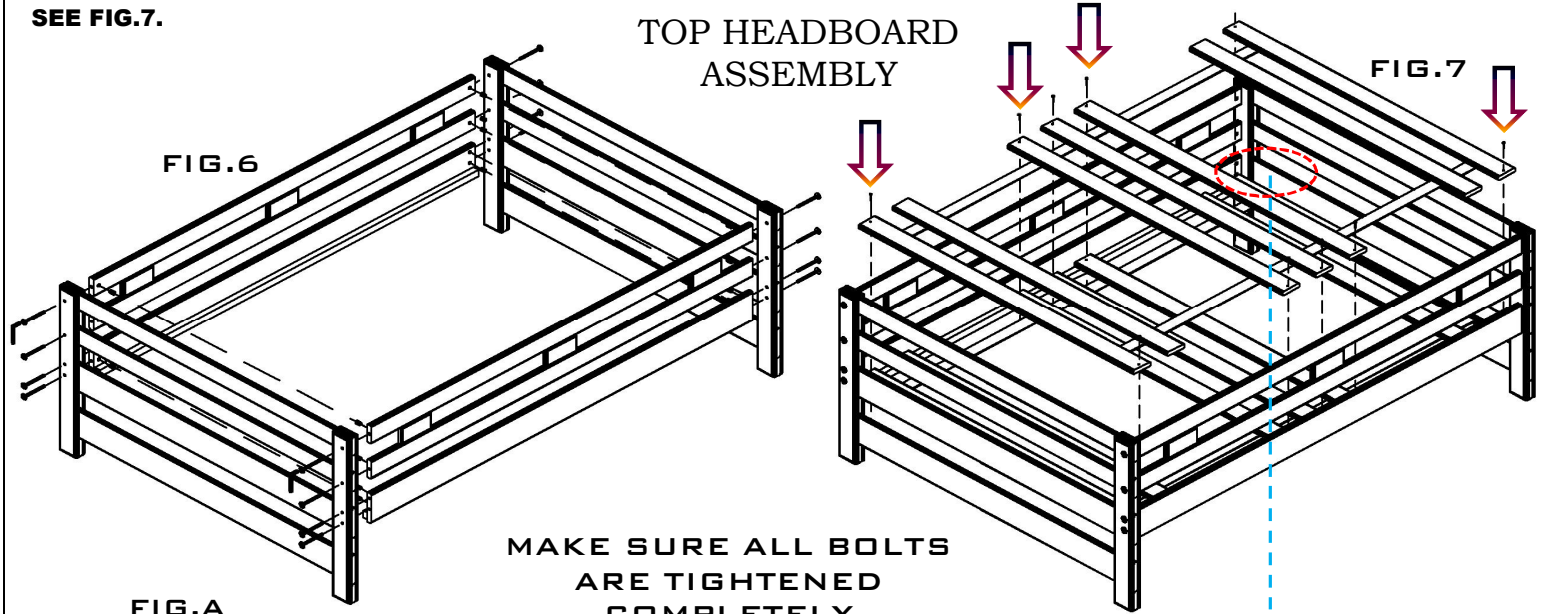

MAKE SURE ALL BOLTS ARE TIGHTENED COMPLETELY

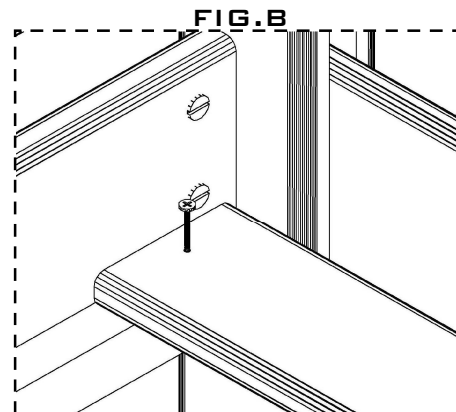
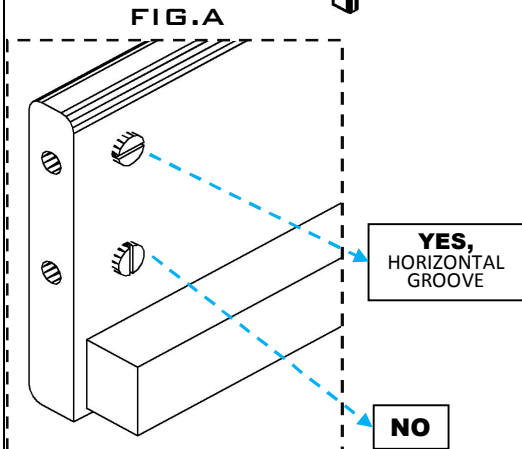

BOTTOM HEADBOARD ASSEMBLY (USE FULL SLAT ROLL 100-647)

- 1.- ASSEMBLE **BOTTOM BUNK BED** BY USING TWO BOTTOM HEADBOARDS (B), AND TWO SIDE RAILS (D).
- 2.- INSERT TWO CROSS DOWEL NUTS (G) IN ACCESS HOLE INSIDE THE SIDE RAIL, ALIGN CROSS DOWEL NUT MAKE SURE THE GROOVE IS HORIZONTAL, **SEE FIG.A**
- 3.- ATTACH TWO SIDE RAILS TO BOTTOM HEADBOARDS, INSERTING TWO 4" HEX TAP BOLTS (F) IN EACH CORNER OF BOTTOM HEADBOARD HOLES, USE 5MM ALLEN WRENCH (H) TO TIGHTEN BOTH HEX TAP BOLTS, (DO NOT TIGHTEN COMPLETELY UNTIL ALL PIECES ARE CONNECTED TOGETHER), **SEE FIG.8**
- 4.- REPEAT THE SAME PROCESS ON ALL FOUR CORNERS.
- 5.- PLACE FULL SLAT ROLL (I) INSIDE THE BOTTOM BUNK BED PUSH SLAT PACK AGAINST THE BED END POST (FIG.B) AND SECURE WITH TWO 1 1/4" SCREWS (J) IN EACH SLAT, **SEE FIG.9**
- 6.- INSERT ONE METAL DOWEL PIN (C) IN EACH BOTTOM HDBD TOP HOLES (FIG.I), WITH HELP PLACE IT ON TOP HDBD ASSEMBLY ON TOP BOTTOM HDBD ASSEMBLY ALIGNING METAL DOWEL PINS WITH EACH PRE-DRILLED HOLE IN BOTH ENDS UNTIL THE METAL DOWELS PIN ARE ALL IN, **SEE FIG.10**

BOTTOM HEADBOARD ASSEMBLY

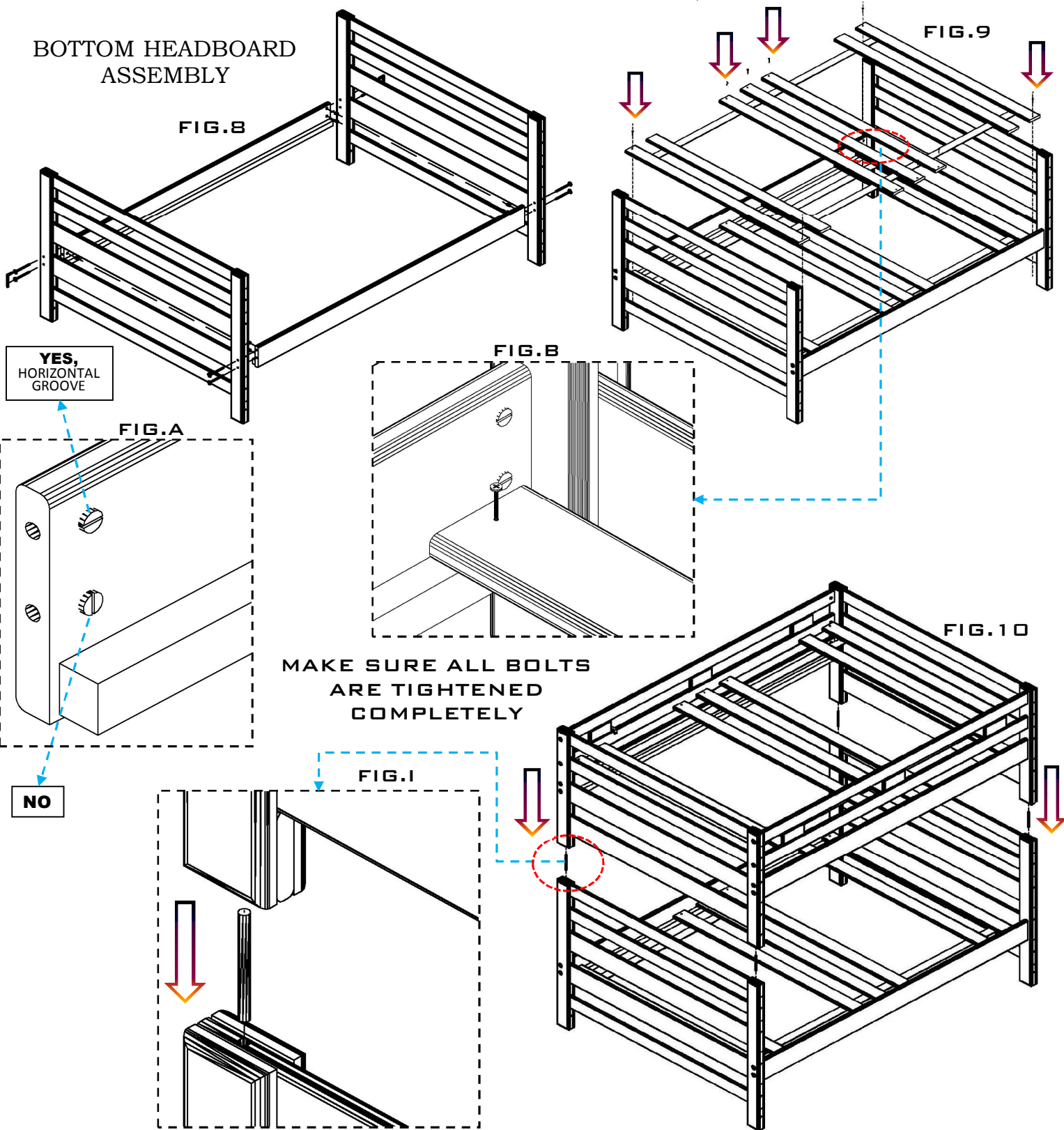

YES,
HORIZONTAL
GROOVE

FIG.A

FIG.B

FIG.9

FIG.10

FIG.I

MAKE SURE ALL BOLTS
ARE TIGHTENED
COMPLETELY

NO

IF YOU PURCHASE KD TRUNDLE STORAGE (K), SLIDE UNDER BOTTOM SIDE RAILS IN THE BED, **SEE FIG.11**

LADDER ASSEMBLY

ALIGN THE PRE-DRILLED HOLES IN LONG PART OF METAL HOOKS BRACKETS (M) WITH THE PRE-DRILLED HOLES IN THE LADDER (L), SECURE WITH 1" SCREWS (N) USING PHILLIPS HEAD SCREWDRIVER (**NOT INCLUDED**), **SEE FIG.C** AND HOOK THE LADDER IN THE PROPER POSITION, ADJUST AND ALIGN THE PRE-DRILLED HOLES IN THE SHORT PART OF METAL HOOKS ON TOP GUARD RAIL TO SECURE THE LADDER SEE FIG.D, AS SHOWN IN **FIG.12**

MAKE SURE ALL BOLTS ARE TIGHTENED COMPLETELY

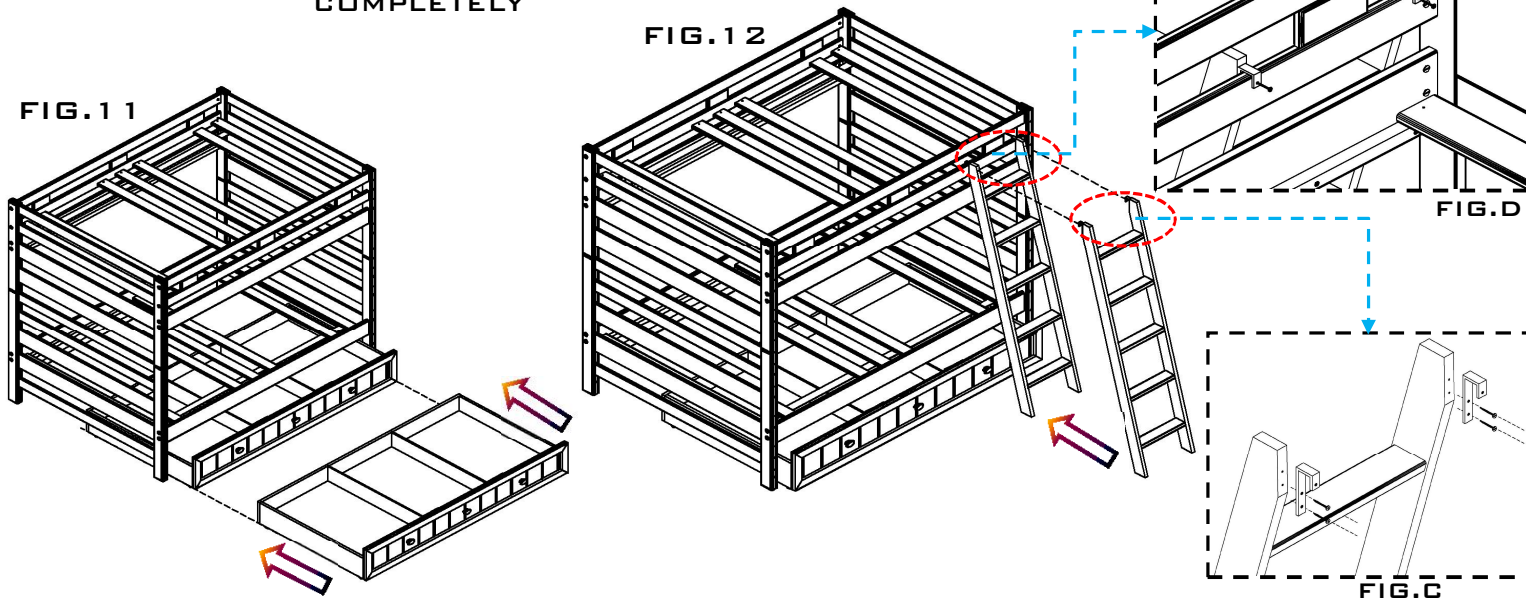

SAFETY WARNINGS

- 1.- FOLLOW THE INFORMATION ON THE WARNINGS APPEARING ON THE UPPER BUNK END STRUCTURE AND ON THE CARTON. DO NOT REMOVE WARNING LABEL FROM BED.
- 2.- ALWAYS USE THE RECOMMENDED SIZE MATTRESS OR MATTRESS SUPPORT, OR BOTH TO HELP PREVENT THE LIKELIHOOD OF ENTRAPMENT OR FALLS.
- 3.- SURFACE OF MATTRESS MUST BE AT LEAST 5 IN BELOW THE UPPER EDGE OF GUARDRAILS.
- 4.- DO NOT ALLOW CHILDREN UNDER 6 YEARS OF AGE TO USE THE UPPER BUNK.
- 5.- PROHIBIT MORE THAN ONE PERSON ON UPPER BUNK.
- 6.- PERIODICALLY CHECK AND ENSURE THAT THE GUARD RAIL, LADDER AND OTHER COMPONENTS ARE IN THEIR PROPER POSITION, **FREE FROM DAMAGE**, AND THAT ALL CONNECTORS ARE TIGHT.
- 7.- DO NOT ALLOW HORSEPLAY ON OR UNDER THE BED AND PROHIBIT JUMPING ON THE BED.
- 8.- ALWAYS USE THE LADDER FOR ENTERING AND LEAVING THE UPPER BUNK.
- 9.- DO NOT USE SUBSTITUTE PARTS. CONTACT THE MANUFACTURER OR DEALER FOR REPLACEMENT PARTS.
- 10.- USE OF A NIGHT LIGHT MAY PROVIDE ADDED SAFETY PRECAUTION FOR A CHILD USING THE UPPER BUNK.
- 11.- IF THE BUNK BED WILL BE PLACED NEXT TO THE WALL THE GUARDRAIL THAT RUNS THE FULL LENGTH OF THE BED SHOULD BE PLACED AGAINST THE WALL TO PREVENT ENTRAPMENT BETWEEN THE BED AND THE WALL.
- 12.- ALWAYS USE GUARDRAILS ON BOTH LONG SIDES OF THE UPPER BUNK.
- 13.- THE USE OF WATER OR SLEEP FLOTATION MATTRESSES IS PROHIBITED.
- 14.- **STRANGULATION HAZARD.** NEVER ATTACH OR HANG ITEMS TO ANY PART OF THE BUNK BED THAT ARE NOT DESIGNED FOR USE WITH THE BED, FOR EXAMPLE BUT NOT LIMITED TO HOOKS, BELTS AND JUMP ROPES.
- 15.- KEEP THESE INSTRUCTIONS FOR FUTURE REFERENCE.

SIZE OF MATTRESS AND FOUNDATION

THE UPPER & LOWER BUNK BED IS DESIGNED TO USE ONLY A MATTRESS WHICH IS **74"** TO **75"** LONG AND **52 1/2"** TO **53 1/2"** WIDE FOR **FULL BED**. THE BUNKIE BOARD IS REQUIRED TO **52 1/2"** WIDE X **74"** LONG FOR **FULL BED**.

NOTE: ENSURE THICKNESS OF MATTRESS AND FOUNDATION COMBINED DOES NOT EXCEED **10"** AND MATTRESS IS AT LEAST **5"** BELOW UPPER EDGE OF GUARDRAILS.

REPLACEMENT PARTS

REPLACEMENT PARTS, INCLUDING ADDITIONAL GUARDRAILS, MAY BE OBTAINED FROM ANY OF OUR CANYON FURNITURE COMPANY DEALERS.