

PRINCESS

Changing Tray

Model: PN-CS-7910CS-SIL / PN-CS-7910CS-WHT
CS7910CS-S / CS7910CS-W

SKU #: 39479109 & 39479084



sample tested to meet U.S. Federal,
ASTM and other safety requirements.

Assembly Instruction

WARNING

Fall Hazard - Children have suffered serious injuries after falling from changing tables.

Falls can happen quickly.

STAY in arm's reach of your child.

ALWAYS secure this product to the support frame by (manufacturer's instructions for securing the changing table accessory) See instructions.

SUFFOCATION HAZARD: Babies have suffocated while sleeping in changing area.

Changing area are not designed for safe sleeping.

NEVER allow baby to sleep in changing area.

 **WARNING !** When child reaches a maximum weight o 30 lbs, the changing table shall no longer be use.

The changing pad used should be 16.5" (41.9cm) W x 32.5" (82.55cm) L with a maximum thickness of 1" (2.54cm).

Always secure this pad to the changing surface by buckling the safety strap. See instructions.

Keep instructions for future use.

Congratulations on your purchase of a Westwood product. We take great pride in the quality and design of our furniture. It is important that you read these instructions carefully and completely to ensure that this product functions as it was designed.







After opening the package, check to see that all the parts are present. If you think something is missing, please contact your retailer, and they can arrange to have the missing parts quickly replaced. You can also contact us directly, by calling 1-908-719-4707, or emailing support@westwoodbaby.com. If any aspect of these instructions is unclear, please contact your retailer or Westwood Design for assistance.

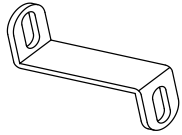

635 N. Billy Mitchell Rd.,
Salt Lake City, UT 84116
Phone: 908-719-4707

www.westwoodbaby.com

WESTWOOD DESIGN

1  69 x19 x 55mm Metal Plate (x2)	2  60 x19 x 3mm Metal Plate (x2)	3  $\text{\O}1/4"$ x 11.5mm x 15mm Bolt (x2)	4  $\text{\O}1/4"$ x 11mm x 1.2mm Spring Washer (x2)	5  $\text{\O}1/4"$ x 18mm x 2mm Flat Washer (x4)	6  $\text{\O}8\text{mm}$ x 19mm Scrw (x2)
7  Allen Key (x1)					

NOTE:

The dresser shown on this instruction is sold separately.
 The metal plate (#1) must be use only for 6 drawer dresser (SKU # 38209929 or 37809994),
 and 8 drawer dresser (SKU # 37909922 or 37909996).

STEP 1:





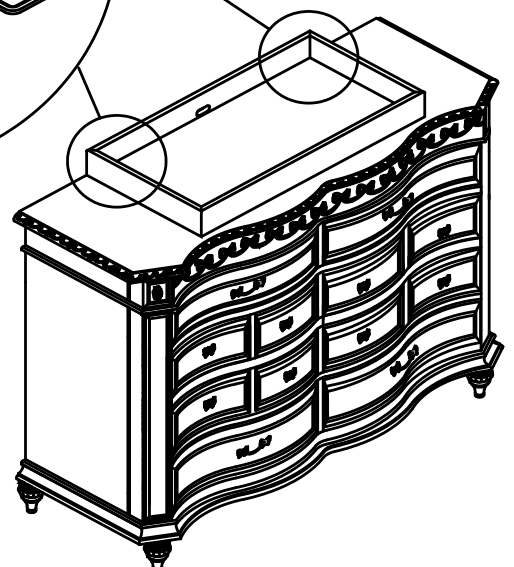
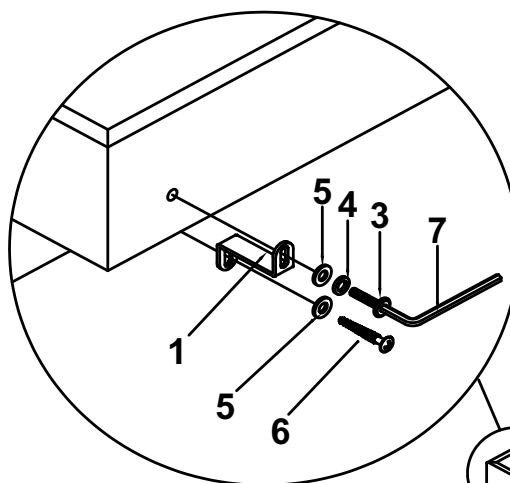
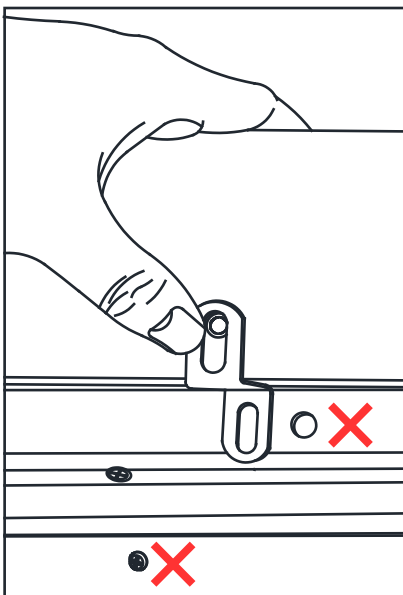

Attach the metal plate (1) to the back of the tray using flat washer (5), spring washer (4), bolt (3) and allen key wrench (7).
 Secure the tray to the dresser (purchased separately) using screw (6) and a Phillips head screwdriver (not provided).
 Make sure all the bolts and screws are tighten firmly before use.

NOTE- Screws (6) will make their own holes into the dresser top pane

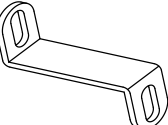

The topper unit **CANNOT** be attached using the pre-existing holes on the dresser.
 Screws (6) will make their own holes into the dresser top panel.

WESTWOOD DESIGN

1  69 x 19 x 55mm Metal Plate (x2)	2  60 x 19 x 3mm Metal Plate (x2)	3  $\text{\O}1/4"$ x 11.5mm x 15mm Bolt (x2)	4  $\text{\O}1/4"$ x 11mm x 1.2mm Spring Washer (x2)	5  $\text{\O}1/4"$ x 18mm x 2mm Flat Washer (x4)	6  $\text{\O}8\text{mm}$ x 19mm Scrcwe (x2)
7  Allen Key (x1)					

NOTE:

The dresser shown on this instruction is sold separately.
 The metal plate (#2) must be use only for the carriage chest (SKU # 37809920 or 38609991).

STEP 1:

Attach the metal plate (2) to the back of the tray using flat washer (5), spring washer (4), bolt (3) and allen key wrench (7).
 Secure the tray to the dresser (purchased separately) using screw (6) and a Phillips head screwdriver (not provided).
 Make sure all the bolts and screws are tighten firmly before use.

NOTE- Screws (6) will make their own holes into the dresser top pane

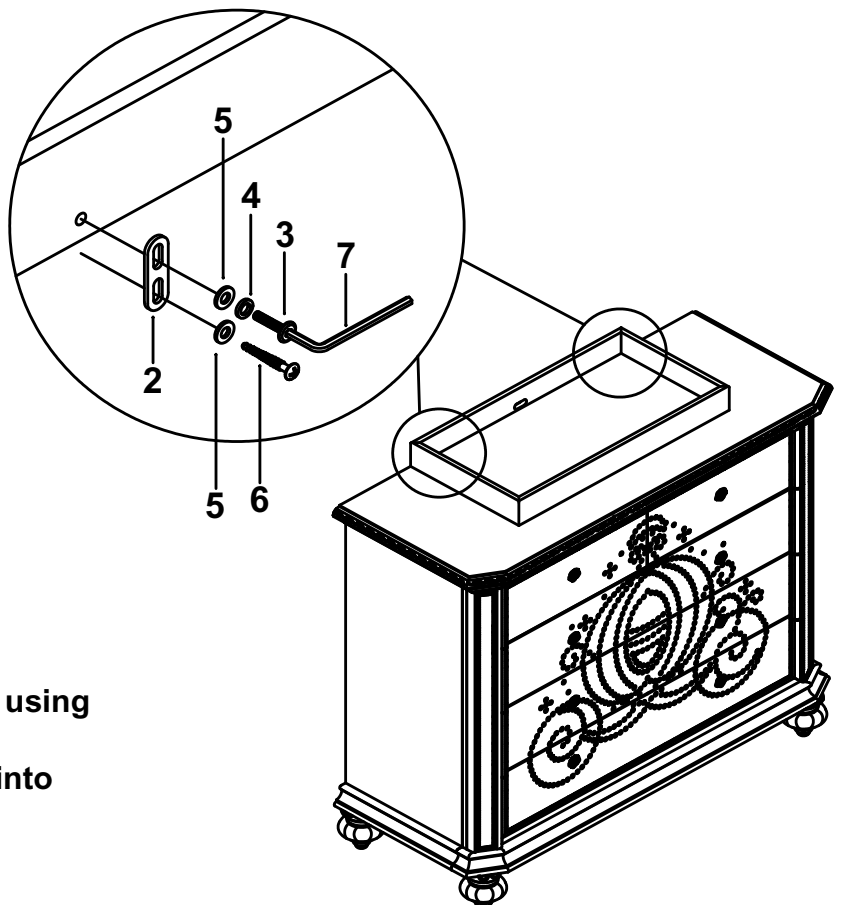
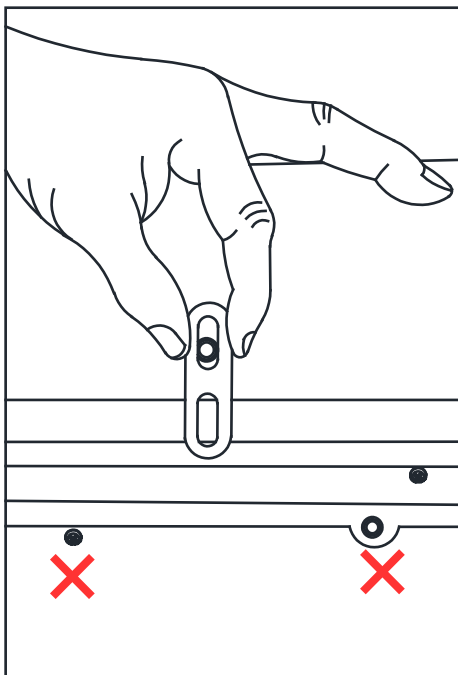

The topper unit **CANNOT** be attached using the pre-existing holes on the dresser.
 Screws (6) will make their own holes into the dresser top panel.