

# ASSEMBLY INSTRUCTIONS

For CONVERSION LEG  
CONNELY  
Model # 27578

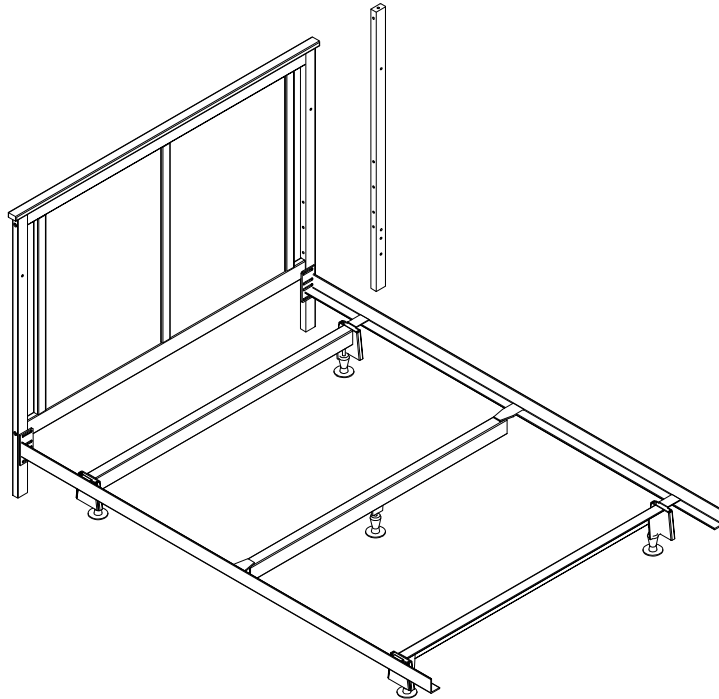

*suitebebe*

"THE PRODUCT IMAGES SHOWN ARE FOR ILLUSTRATION PURPOSES ONLY AND MAY NOT BE AN EXACT REPRESENTATION OF THE PRODUCT."

BED FRAME and HEADBOARD sold separately.  
Please contact retailer.

Carefully remove and lay out all parts. Familiarize yourself with all exhibits and diagrams to facilitate the assembly of your bed

**TOOLS REQUIRED :**

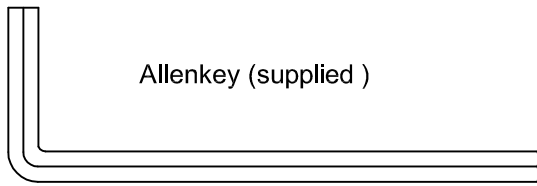

Phillips head screw driver ( unsupplied )

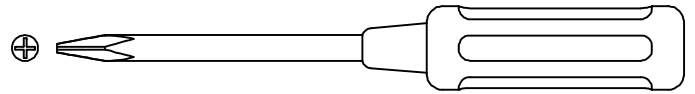

**PART ENCLOSED IN CARTON**

CONVERSION LEG ( 1 pc)



**HARDWARE**

F. Allenbolt 3 1/8" (80 mm) (2 pcs )

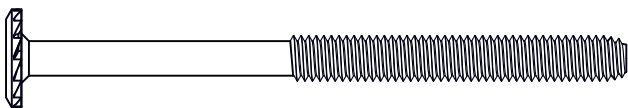

P. Wooden Dowel 1 1/4" [30 mm] (1 pc)



M. Barrel Nut 5/8" x 3/8" (15 mm x 10 mm )( 2 pcs )

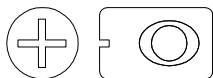

N. Allenkey ( 1 pc ) (length may vary)



W. Spring Washer (2 pcs)



Make sure the bolts are tightly locked against the washers during assembly.  
(Please add an extra 1/2 revolution to all the bolts when using spring washer after tightening)

# STEP 1 " ASSEMBLY OF HEADBOARD LEG "

## THIS STEP REQUIRES :

CONVERSION LEG ( 1 pc)

Headboard ( 1 pc ) - SOLD SEPARATELY

M. Barrel Nut 5/8" x 3/8"  
(15 mm x 10 mm)(2 pcs )

P. Wooden Dowel  
1 1/4" [30 mm] (1 pc)

W. Spring Washer  
(2 pcs)

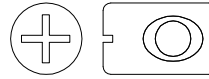

N. Allenkey ( 1 pc )

F. Allenbolt 3 1/8" (80 mm) (2 pcs )

Phillips head screw driver ( unsupplied )

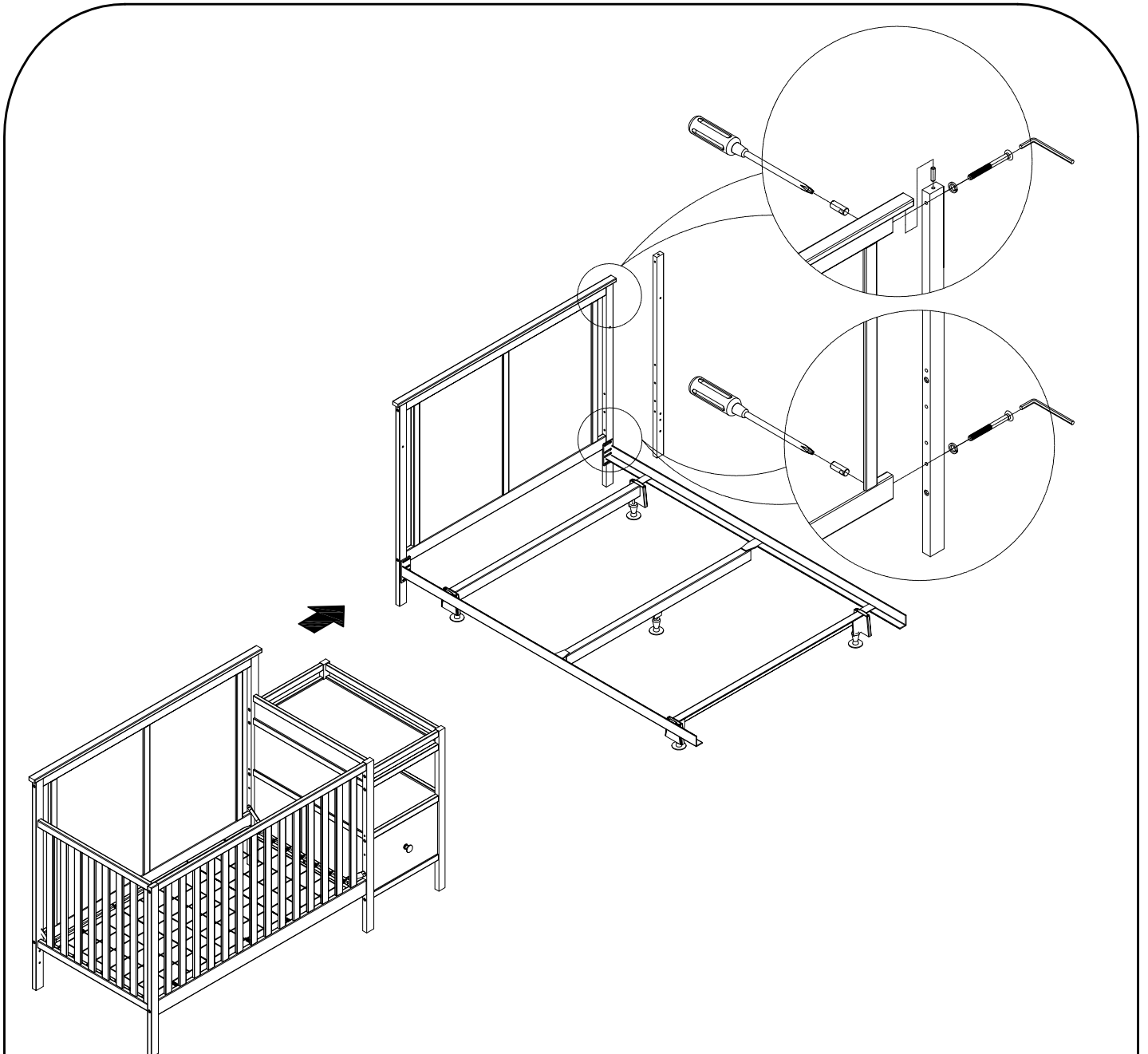
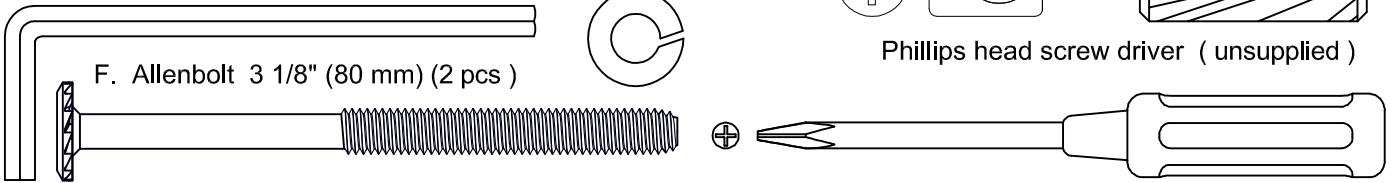

- Insert wooden dowel (P) into the top hole on conversion leg and into the hole in the bottom side of headboard top frame.
- Insert barrel nut 5/8" x 3/8"(15 mm x 10 mm)(M) into the top and bottom holes in head board backside.
- Connect conversion leg to the headboard using 2 pcs allenbolt 3 1/8"(80 mm)(F), spring washer (W) and barrelnut (M).
- Tighten all bolts with allenkey (N).