

Item # : TW60M  
Assembly Instructions

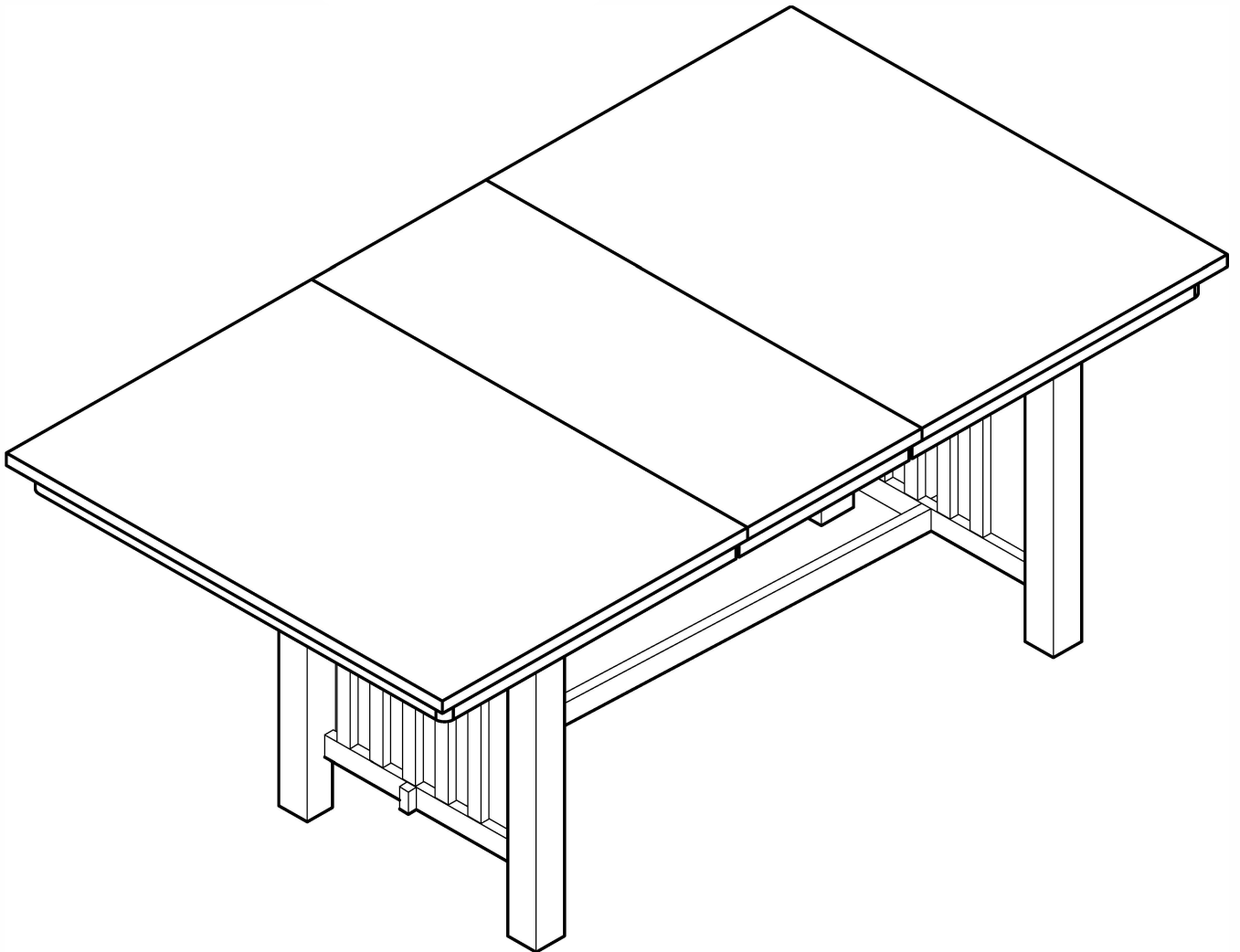

*Please visit our website for the most current instructions, assembly tips, report damage, or request parts. [www.walkeredison.com](http://www.walkeredison.com)*

Revised 03/2017

# General Assembly Guidelines



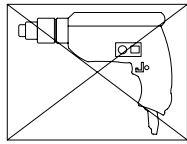



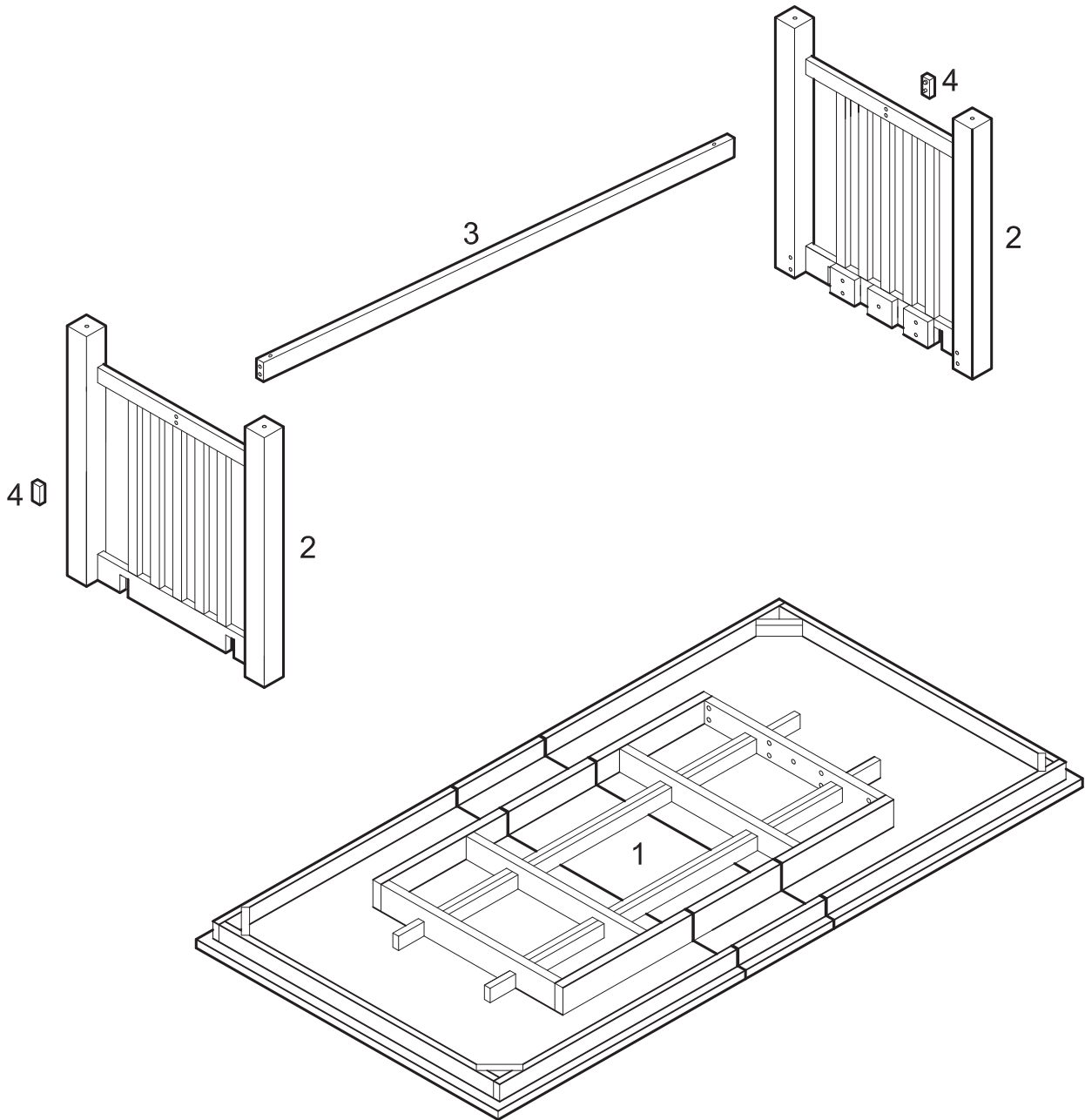

- I. Insure that all parts and hardware are available before beginning assembly.
- II. Follow each step carefully to insure the proper assembly of this product.
- III. Two people are recommended for ease in the assembly of this product.
- IV. The main types of hardware used to assemble this product are wood dowels, nuts, bolts and washers.
- V. Power tools should not be used to assemble this product.



# Parts List



# Hardware List

A		Ø10*35(mm)	Wood dowel	2 pcs
B		Ø6*60(mm)	Bolt	2 pcs
C			Nut	2 pcs
D		Ø6*50(mm)	Bolt	18 pcs
E		Ø1/4"	Spring washer	18 pcs
F		Ø1/4"	Washer	18 pcs
G			Foot	4 pcs
H		M4(mm)	Wrench	1 pc

*The hardware quantities listed above are required for proper assembly.  
Some extra hardware may also have been included.*

# Assembly Options

## Option A

To build this option, follow Steps 1-6.

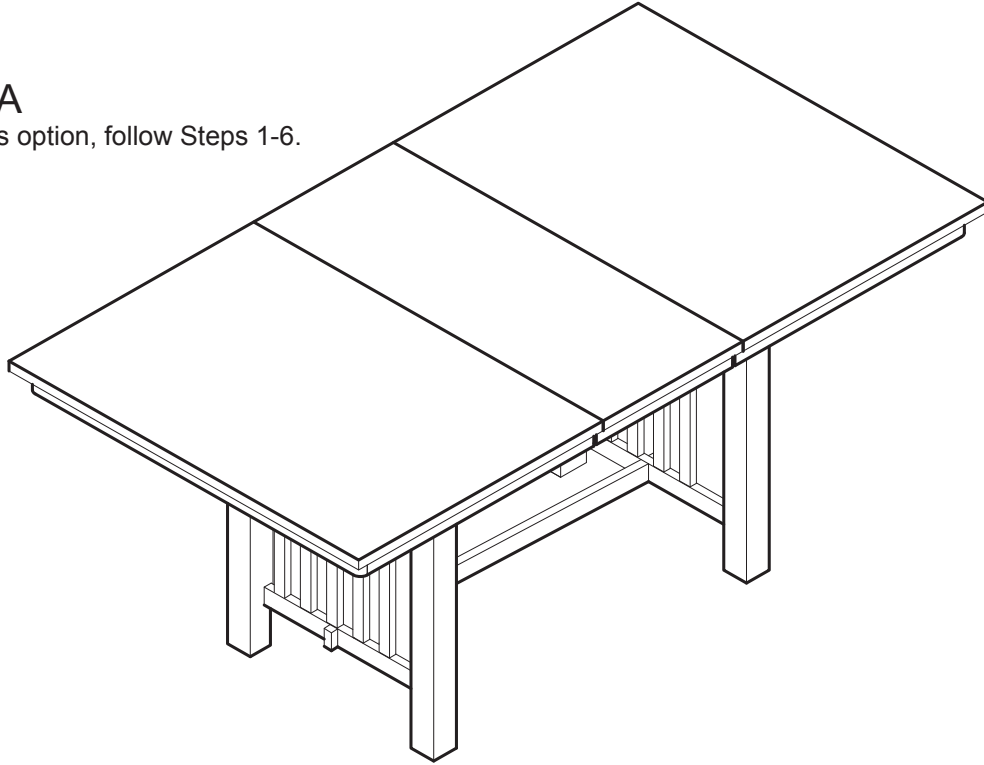

## Option B

To remove the table leaf, follow Steps 7-10.

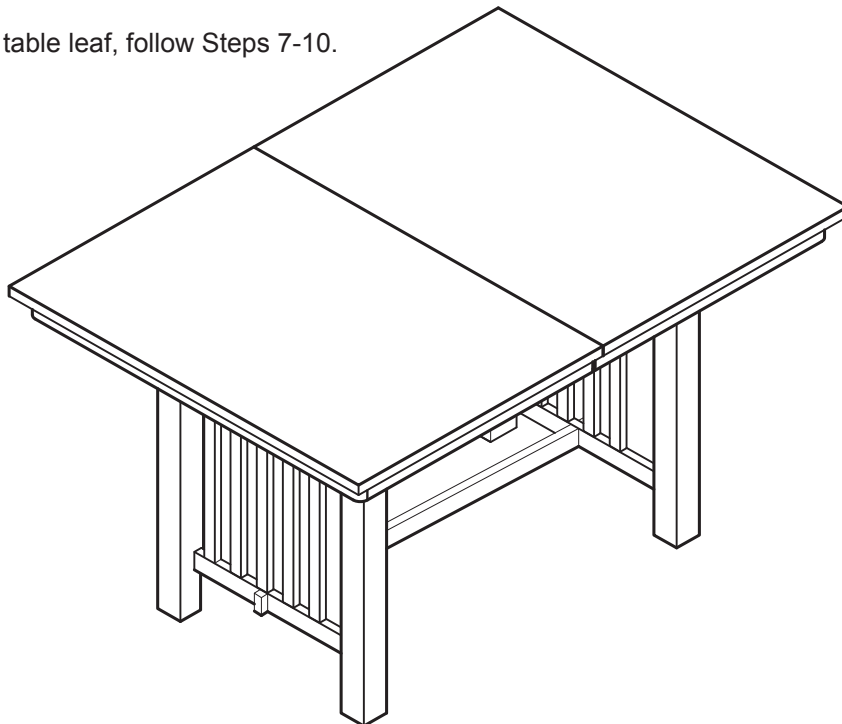

# Step 1

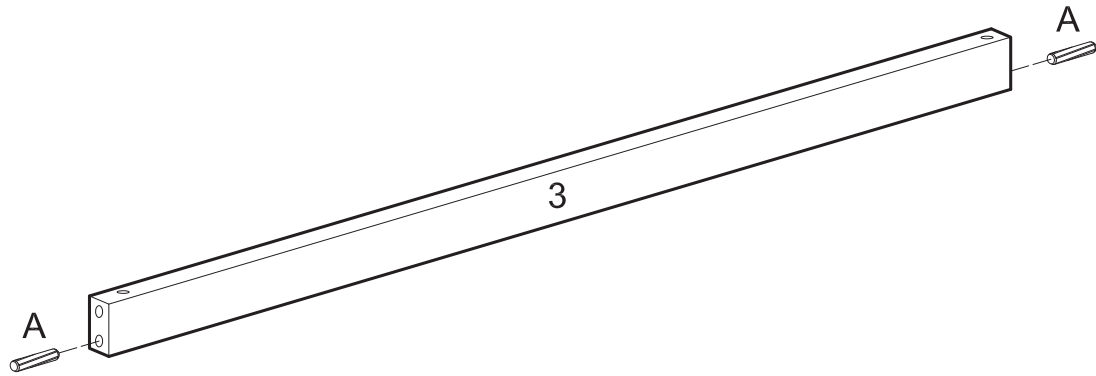

Insert dowels (A) into crossbar (3).

# Step 2

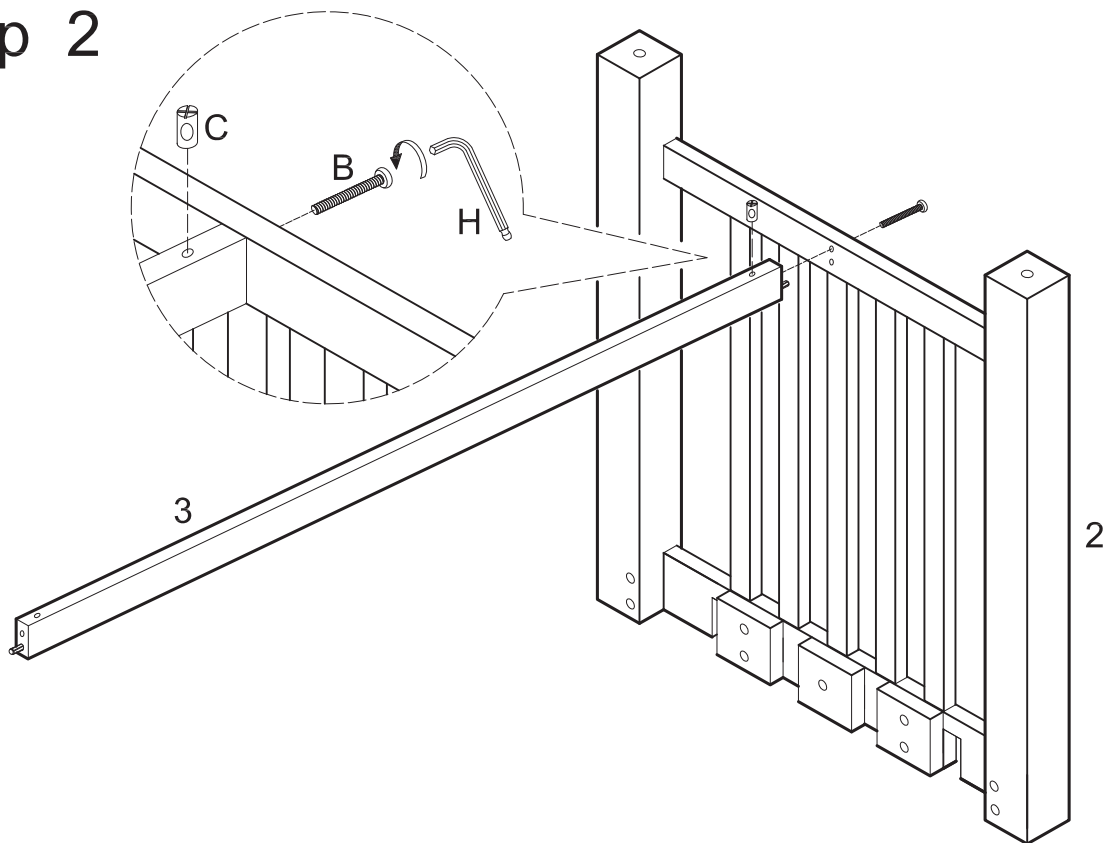

Insert nut (C) into crossbar (3). Attach crossbar (3) to leg piece (2) using bolt (B). Tighten bolt (B) with wrench (H). Bolt (B) will screw directly into nut (C).

## Step 3

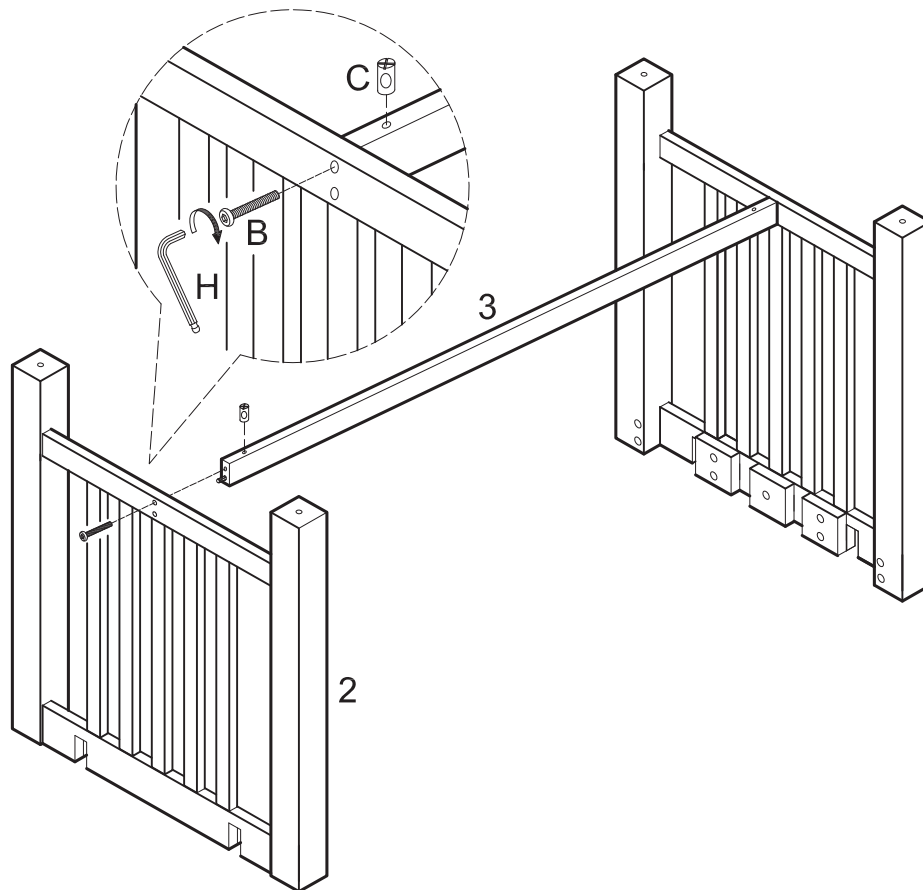

Insert nut (C) into opposite end of crossbar (3). Attach crossbar (3) to second leg piece (2) using bolt (B). Tighten bolt (B) with wrench (H). Bolt (B) will screw directly into nut (C).

## Step 4

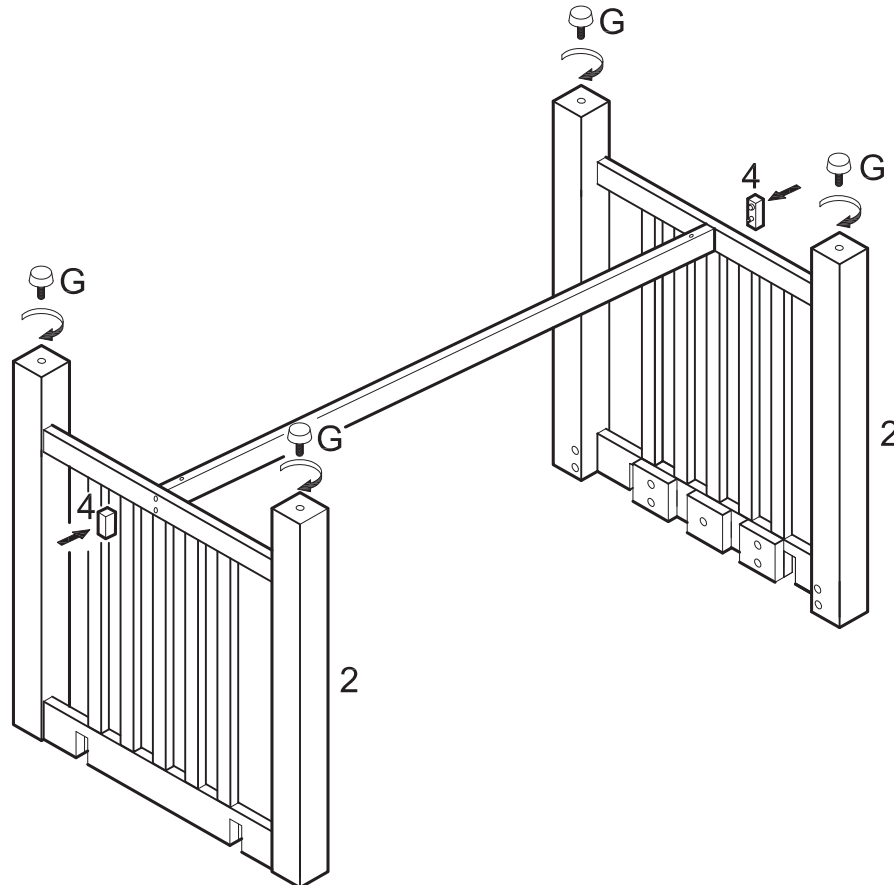

Screw feet (G) into leg pieces (2). Insert end caps (4) into leg pieces (2) using pre-inserted dowels as guides.

## Step 5

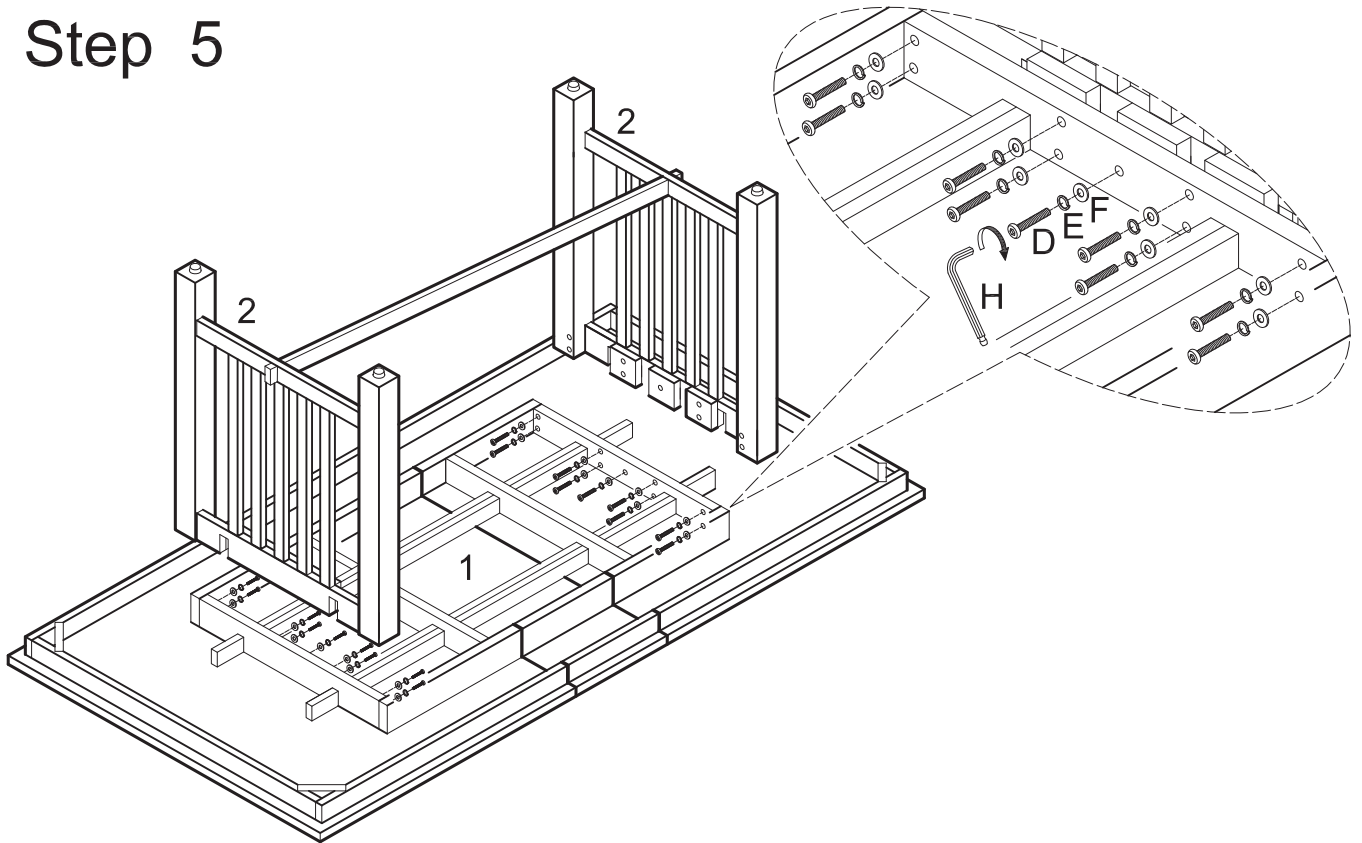

Attach leg pieces (2) to table top (1) using bolts (D), spring washers (E) and washers (F). Tighten all bolts (D) with wrench (H).

## Step 6

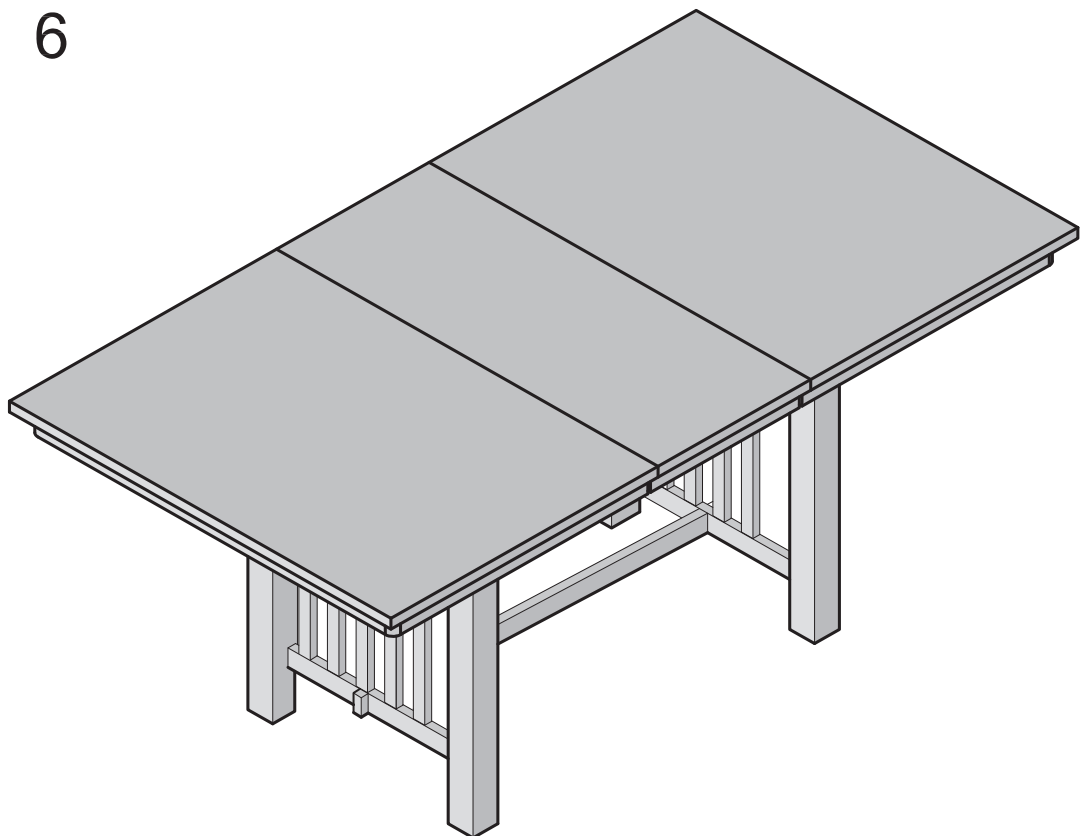

Option A Final



## Step 7

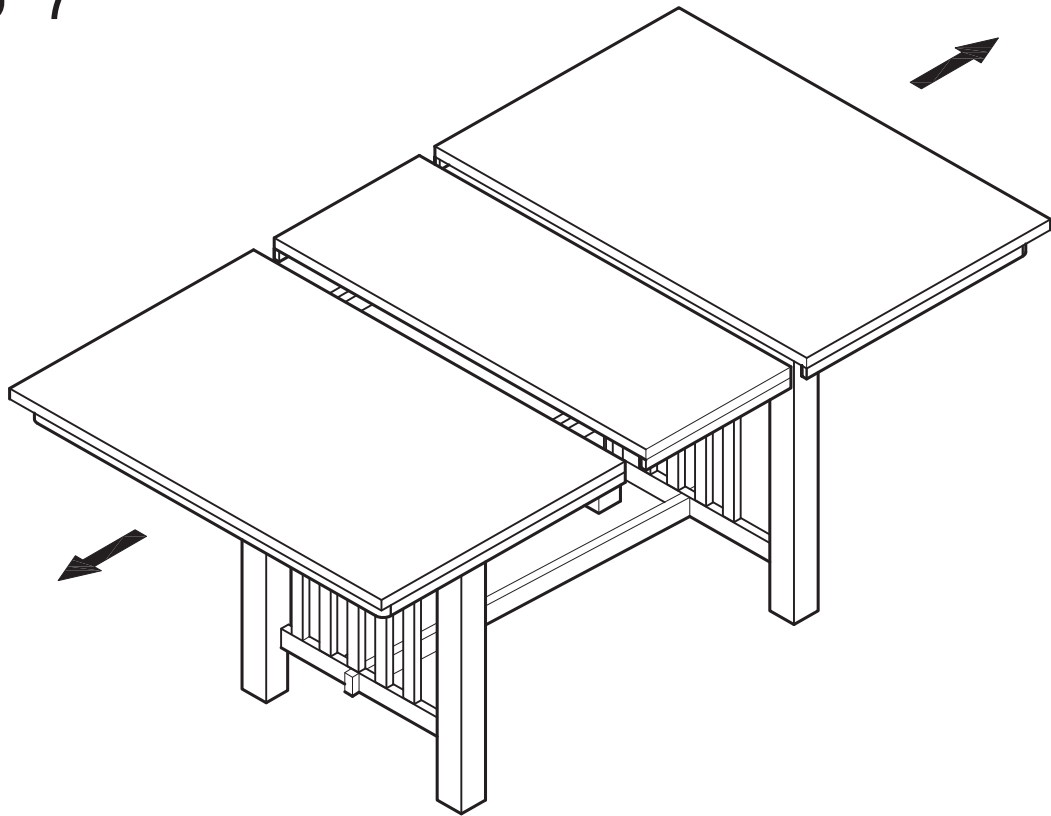

Carefully pull table apart.

## Step 8

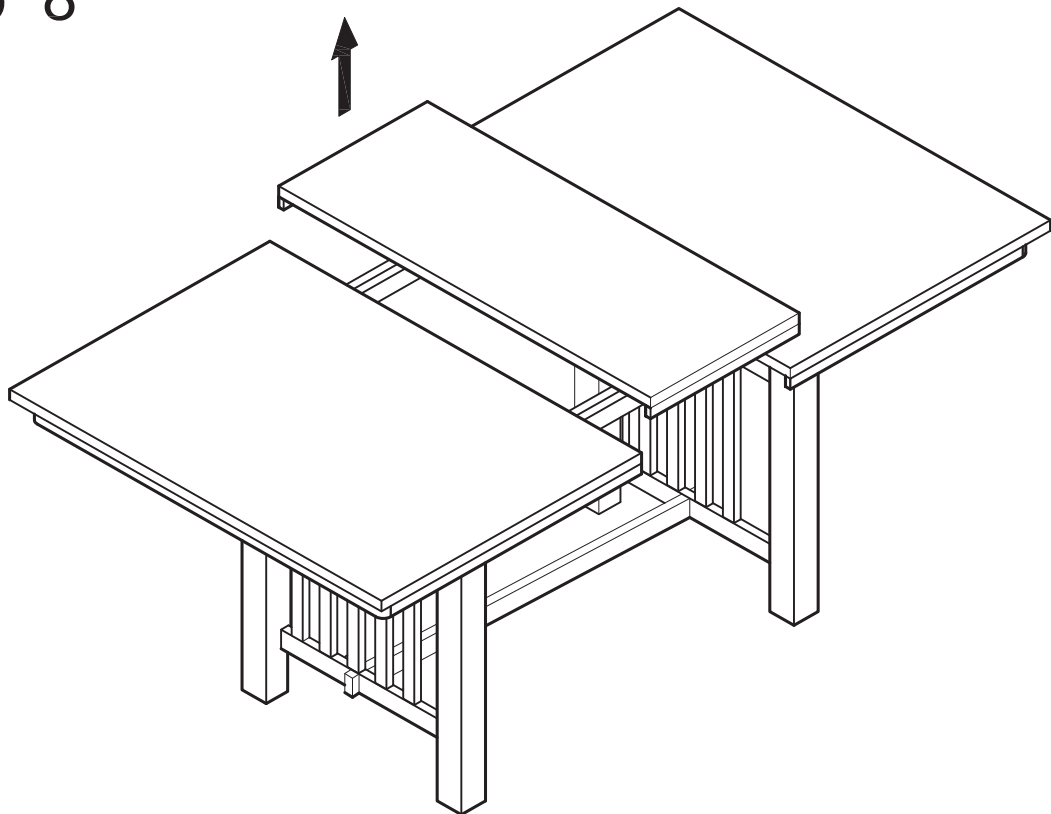

Carefully remove center leaf from table.

## Step 9

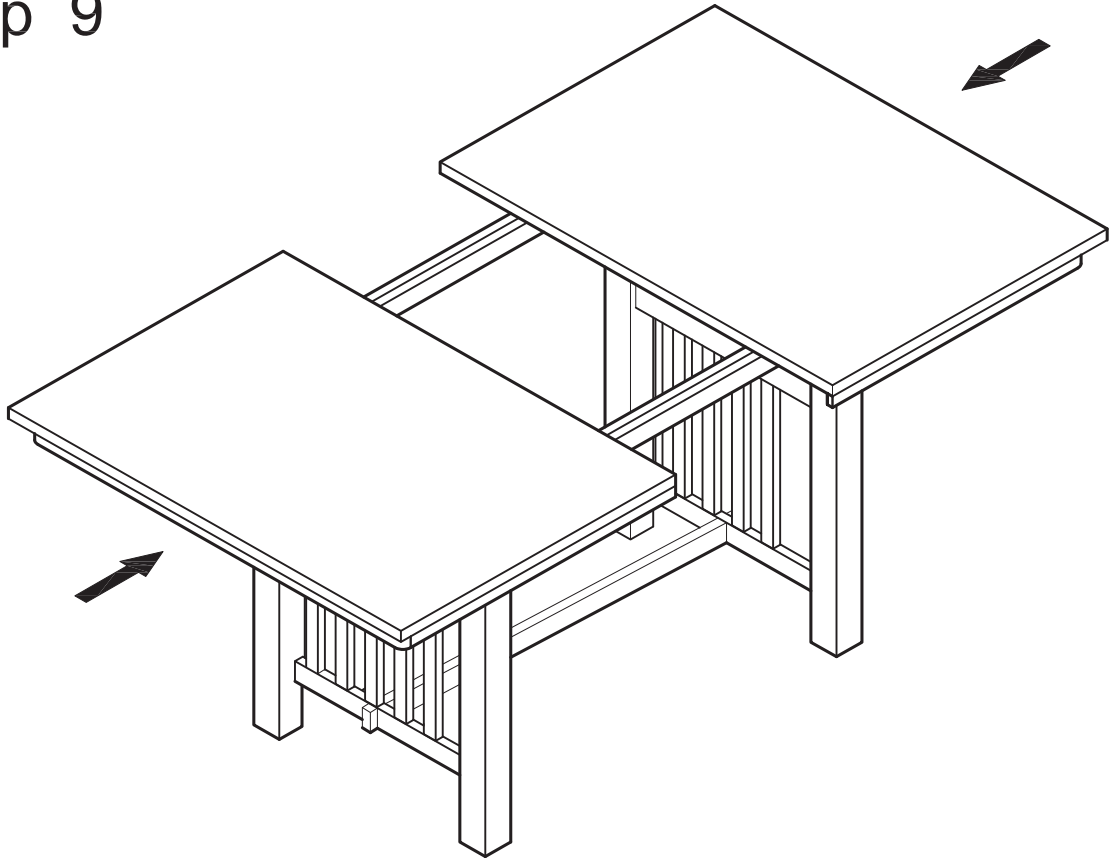

Carefully push table back together.

## Step 10

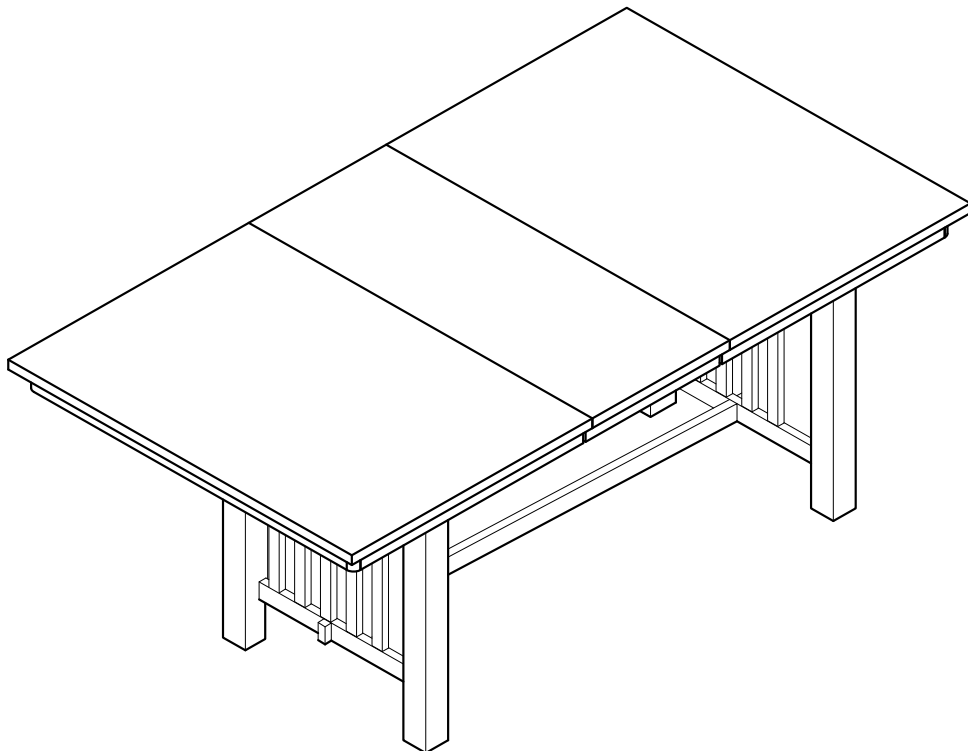

Option B Final